



Designation: **E894 – 88 (Reapproved 2010) E894 – 18**

Standard Test Method for Anchorage of Permanent Metal Railing Systems and Rails for Buildings¹

This standard is issued under the fixed designation E894; the number immediately following the designation indicates the year of original adoption or, in the case of revision, the year of last revision. A number in parentheses indicates the year of last reapproval. A superscript epsilon (ϵ) indicates an editorial change since the last revision or reapproval.

1. Scope

1.1 This test method describes procedures to be followed in testing the performance of the anchorage of all types of new and existing permanent metal railing systems (guard, stair, and ramp-rail systems), and rails (hand, grab, and transfer rails) installed in and for agricultural, assembly, commercial, educational, industrial, institutional, recreational, and residential buildings.

1.2 This test method is applicable to railing systems and rails having major structural components made of metal and secondary components made of metal or other materials such as wood, plastics, and glass.

1.3 The test method described can be used to determine whether the anchorage of permanent metal railing systems and rails complies with anticipated performance requirements.

1.4 Specifically, this test method covers procedures for determining the static tension, shear, and moment resistance of anchorages for permanent metal railing systems, and rails in structural elements made of concrete, masonry, wood, and metal as well as related products.

1.5 No consideration is given in this test method to any possible deterioration of anchorage systems, resulting from adverse environmental conditions. The performance of special tests covering this aspect may be desirable.

1.6 Should computations make it possible to provide the needed information, testing may be employed for purposes of verification.

1.7 The values stated in SI units are to be regarded as standard. The values given in parentheses are mathematical conversions to inch-pound units that are provided for information only and are not considered standard.

1.8 *This standard does not purport to address all of the safety concerns, if any, associated with its use. It is the responsibility of the user of this standard to establish appropriate safety, health, and environmental practices and determine the applicability of regulatory limitations prior to use.* For specific hazard statements, see Section 6.

1.9 *This international standard was developed in accordance with internationally recognized principles on standardization established in the Decision on Principles for the Development of International Standards, Guides and Recommendations issued by the World Trade Organization Technical Barriers to Trade (TBT) Committee.*

2. Referenced Documents

2.1 *ASTM Standards:*²

[E4 Practices for Force Verification of Testing Machines](#)

[E488/E488M Test Methods for Strength of Anchors in Concrete Elements](#)

[E575 Practice for Reporting Data from Structural Tests of Building Constructions, Elements, Connections, and Assemblies](#)

[E631 Terminology of Building Constructions](#)

[E985 Specification for Permanent Metal Railing Systems and Rails for Buildings \(Withdrawn 2015\)](#)³

3. Terminology

3.1 *Definitions*—For definitions of terms used in this test method, see Terminology [E631](#) and Specification [E985](#).

¹ This test method is under the jurisdiction of ASTM Committee [E06](#) on Performance of Buildings and is the direct responsibility of Subcommittee [E06.56](#) on Performance of Railing Systems and Glass for Floors and Stairs.

Current edition approved Oct. 1, 2010 April 1, 2018. Published November 2010 May 2018. Originally approved in 1982. Last previous edition approved in 2004 2010 as E894 – 88 (2004) (2010). DOI: 10.1520/E0894-88R10-10.1520/E0894-18.

² For referenced ASTM standards, visit the ASTM website, www.astm.org, or contact ASTM Customer Service at service@astm.org. For *Annual Book of ASTM Standards* volume information, refer to the [standard's Document Summary page](#) on the ASTM website.

³ The last approved version of this historical standard is referenced on www.astm.org.

4. Significance and Use

4.1 This test method is intended to provide data from which applicable design data can be derived for a given anchorage.

5. Apparatus

5.1 *Testing Machine*—Any testing machine or loading system capable of imposing forces accurate to within $\pm 1\%$, when calibrated in accordance with Practice E4, is suitable and may be used, provided the requirements of specified rate of loading and recovery are met. The testing device shall be of sufficient capacity to prevent yielding of its various components and shall ensure that the applied tension load remains parallel to the relevant axis of the anchorage assembly and that the applied shear load remains essentially parallel to the surface of the structural anchorage element or component during testing.

5.1.1 *Tension Test*—Suitable systems for applying tension forces to the anchorage assembly are shown in Fig. 1 for laboratory testing and in Fig. 2 for field testing. The bearing plates shall be of sufficient size to prevent failure of the surrounding structural members or components. The loading device shall be attached to the assembly by means of pins or a swivel connector to prevent the direct transfer of bending stresses through the connection.

5.1.2 *Shear Test*—A suitable system for applying shear forces to the anchorage assembly normal to the plane or major axis of the railing is shown in Fig. 3. The loading device shall be of sufficient strength to prevent its yielding during the ultimate capacity tests on the assembly. The bearing plates and connections shall be of sufficient size to prevent local failure of the structural member. The load shall be distributed by means of a load-distribution device which makes it possible for the force to be applied perpendicular to the long axes of the anchors. The bearing plate and other tie-down devices provide a means of holding the anchorage member or component at the required elevation throughout the test. The loading devices shall be of such material as to reduce any damage to the loading contact area of the device to a minimum during application of the shear force and shall be replaced when damaged.

5.1.3 *Flexural Test*—A suitable system for applying tensile forces to the top of the rail post is shown in Fig. 4. The necessary test devices shall fulfill the requirements given in 5.1.2 and be applicable to the flexural test.

5.2 *Anchorage Slip and Railing-System or Rail Deflection Measurements:*

5.2.1 *Tension Test*—Two dial gages, having a smallest division of not more than 0.025 mm (0.001 in.), or any suitable measurement device or calibrated sensor of at least comparable accuracy and sensitivity shall be used to measure slip of the anchored system relative to the anchorage elements or components. The purpose of the instruments is to measure the vertical movement of the anchored system with respect to such points on the structural members or components which can serve as reference points without being influenced by the force applied by the anchoring system (see Fig. 1 and Fig. 2). The slip to be used for the evaluation of the findings shall be the average deformation indicated by the two dial gages, measurement devices, or sensors.

5.2.2 *Shear Test*—A single dial gage, having a smallest division of not more than 0.025 mm (0.001 in.), or any suitable measurement device or calibrated sensor of at least comparable accuracy and sensitivity shall be used to measure slip of the anchored system relative to the anchorage elements or components.

5.2.3 *Flexural Test*—A single dial gage for the test shown in Fig. 4, having a smallest division of not more than 0.25 mm (0.01 in.), or any suitable measurement device or calibrated sensor of at least comparable accuracy and sensitivity shall be used to measure the horizontal displacement of the top of the rail post relative to its original location prior to load application.

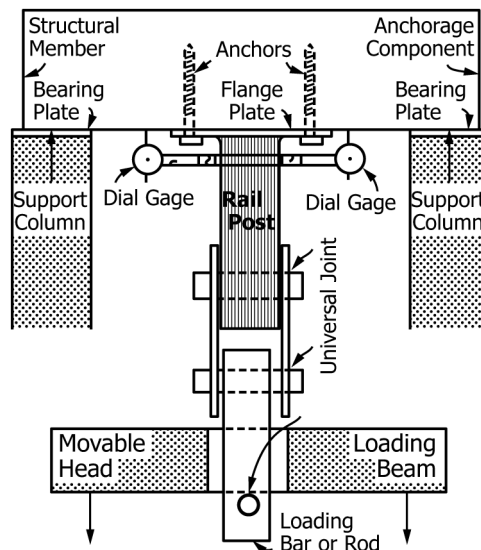

NOTE 1—See Test Method E488/E488M, Fig. 1 for alternative test set-up with a testing machine in the laboratory.
FIG. 1 Diagrammatic Test Set-up for Applying Tensile Force to Rail, Rail Post, Flange Plate, and Flange-Plate Anchors

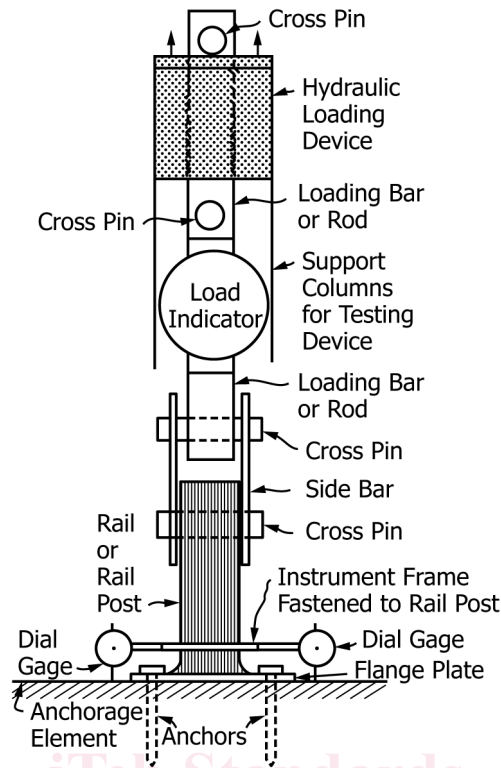

FIG. 2 Diagrammatic Test Set-up for Applying Tensile Force to Rail, Rail Post, Flange Plate, and Flange-Plate Anchors with Field-testing Device

6. Hazards

6.1 Possible injury to personnel and damage to the test equipment and instrumentation prior to, during, and after load application by any unexpected release of potential strain energy accumulated during testing can occur and must be given consideration.

6.2 If tests are conducted in a structure and not in a testing laboratory, exercise caution against unwanted damage to the building, its components, and its finish.

7. Anchorage Considerations

7.1 Anchorage requirements should be based on design and performance requirements. The fastenings and fasteners used for the anchorage to be tested shall be designed in accordance with the specified materials and applicable specifications and shall be installed in accordance with the manufacturer's or designer's specification or, where specific deviations are justified, in accordance with good field practice. Typical anchorages are shown in Appendix X1 in diagrammatic form.

8. Test Selection

8.1 Only that particular test needs to be performed that is considered necessary to provide information required by the requesting party, testing agency, and regulatory body involved or Authority Having Jurisdiction (AHJ), or combinations thereof.

9. Test Specimens

9.1 *Structural System*—The structural elements and components of the structural assembly to be tested shall be in accordance with and typical of the materials and configurations specified, except that the overall size of the test specimens may be reduced to such an extent that the reduction in size is proven to be of no influence on the interpretation of the test data and findings.

9.2 *Anchored System*—The anchored railings and rails to be tested shall be representative of the type and lot to be used in the actual structure.

9.3 *Anchorage System*—The structural anchorage elements and components to be tested shall be representative of the construction to be used in the field.

9.4 *Anchoring System*—The anchoring devices to be tested shall be representative of the type and lot to be used in field construction and shall include, insofar as feasible, all accessory devices and hardware normally required for design and use.

9.5 *Anchorage Installation*—Install the anchoring devices to be tested in accordance with field installation procedures to be used in the building for which the data are applicable.

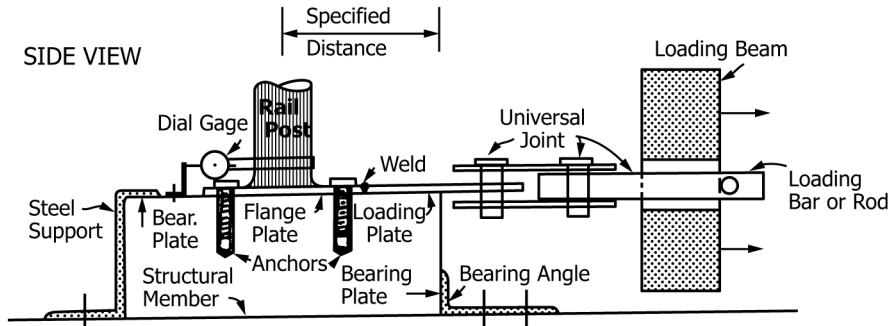

(Weld between flange plate and loading plate can be eliminated if both plates are made from a single plate.)

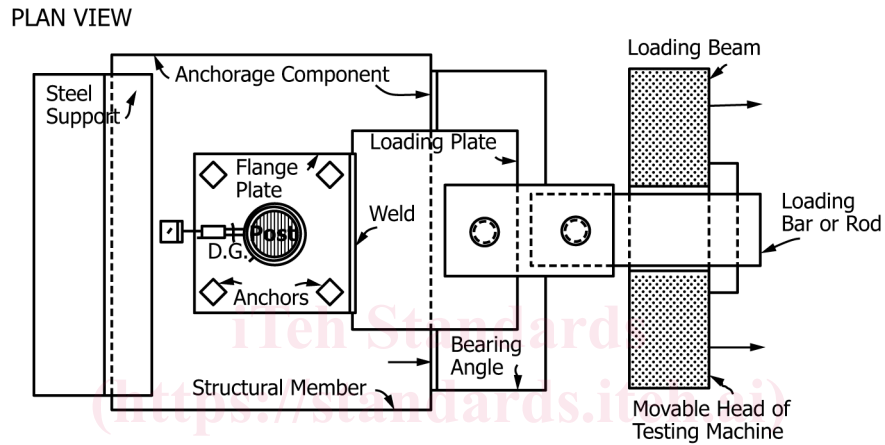

NOTE 1—See Test Methods E488/E488M, Fig. 2, for an alternative test set-up with a testing machine in the laboratory.
FIG. 3 Diagrammatic Test Set-up for Applying Shear Force to Rail Flange, Rail-Post Flange, and Flange Anchors

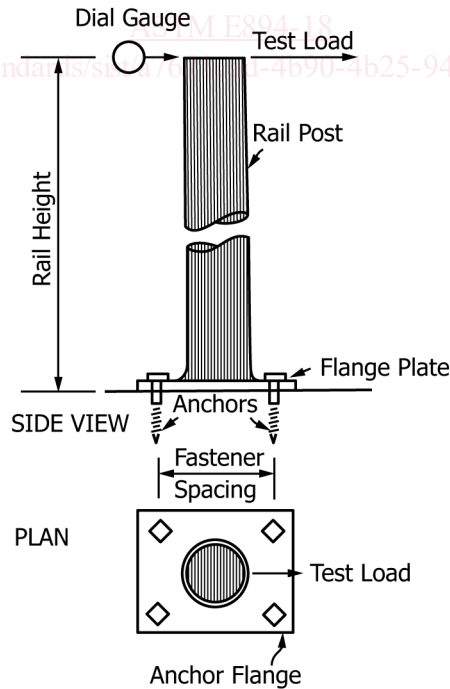

FIG. 4 Diagrammatic Test Set-up for Applying Force to Top of Rail Post to be Tested in Flexure for Determination of Tensile Load Reactions for Rail-Post Anchors

9.6 *Anchorage Placement*—Test all individual anchoring devices and systems used in a given installation individually. Simultaneously test as a complete unit closely spaced anchoring devices and systems that may interact.

10. Number of Test Specimens

10.1 Determine suitable statistical parameters to evaluate the composite variability and to select the number of specimens required to make a realistic determination of the performance characteristics of the anchorage under examination. ~~Consider triplicate test specimens a minimum for~~ Test a minimum of three specimens of each type of anchorage system to be tested under for each set of given conditions. A larger number of specimens may be specified depending upon the design and variability in the quality of the anchorage devices and the anchoring elements and components.

11. Conditioning

11.1 *Conditioning and Curing*—If aging, seasoning, or curing conditions affect the performance and capacity of the anchorage system, take appropriate measures in accordance with the recommendations of the anchor manufacturer, to age, season, or cure the anchorage and anchoring system prior to testing. Report such conditions in detail. Observe their physical effects and fully describe them in the test report.

11.2 *Moisture and Temperature Conditions (applicable only to hygroscopic products)*—If the prevailing moisture and temperature conditions can affect the performance of anchorage systems, hold these parameters constant for a given series of tests on a given anchorage system. The choice of the controlled conditions depends on the environment of the field conditions to be given consideration. Such field conditions may be simulated. Testing shall begin only after the test specimens have reached at least an approximately stable condition with regard to temperature and moisture content.

11.3 *Description*—Examples of typical test specimens are shown in Figs. 1-4 in diagrammatic form. The actual specimen design and size depends on the specific case involved and shall be representative of anticipated field conditions.

12. Procedure

12.1 *Positioning of Loading Systems and Rod:*

12.1.1 *Tension Test (see Figs. 1 and 2)*—Position the structural member or component on the support system in such a way that the bearing plates are equidistant from the center of the anchorage devices and spaced apart so as not to be of any influence on the test findings. Thus, the failure plane of the anchorage system will not intersect with the area below the bearing plates. Position the loading device so that it is centered over the anchorage devices to be tested. Provide uniform contact between the surface of the structural members or components and the support system. If unusual irregularities are present on the surface of the structural element or component, provide a suitable bearing medium between the structural element or component and the support system, such as a paste of calcined gypsum (plaster of paris) or high-strength gypsum. Permit sufficient time before testing to develop the necessary compressive strength of the bearing medium. For all types of bearing media, follow the ~~manufacturer's~~ manufacturer's recommendations as to their use. In the final alignment of the test specimen, ensure that the force to be applied through the loading rod is perpendicular to the surface of the structural members or components.

12.1.2 *Shear Test (see Fig. 3)*—Position and fasten the structural members or components in the support system in such a way that their test surfaces are parallel to the long axis of the shearing devices. For structural members with unusual coarse-textured or finished surfaces, provide a suitable bearing layer between the structural element or component and the support system with a suitable bearing material as described in 12.1.1.

12.1.3 *Flexural Test (see Fig. 4)*—Position the railing post in such a way that the load is applied to the structural member horizontally and essentially perpendicular to the rail without causing any local failure at the point of load application.

12.2 *Mounting of Instruments:*

12.2.1 *Tension Test*—Mount the two dial gages, measurement devices, or sensors as shown in Figs. 1 and 2. Place the sensing elements of the instruments in contact with and normal to the surface of the structural anchorage element or component being tested in such a way as to measure displacement in the direction of the applied load.

12.2.2 *Shear Test*—Mount the single dial gage, measurement device, or sensor as shown in Fig. 3. Place the sensing element of the instrument against a plate fastened to the surface of the structural anchorage element or component in such a way as to measure displacement in the direction of the applied load.

12.2.3 *Flexural Test*—Attach a single dial gage, measurement device, or sensor at the loading point as shown in Fig. 4. Place the sensing element of the instrument in such a way as to measure displacement of the post top in the direction of the applied load.

12.3 *Initial Loading*—Apply an initial load corresponding to approximately 5 % of the estimated maximum load capacity of the assembly to be tested, in order to bring all members into full bearing. This initial load may be changed for any subsequent replicate test depending on the maximum strength of the first assembly tested.

12.4 *Initial Slip Reading*—Observe the initial slip immediately after application of the initial test load.

12.5 *Final Load Application*—In the required step loading during constant-level increment loading up to the maximum load, each increment of load shall amount to not more than 15 % of the estimated maximum test load maintained as constant as is

practical for a 2-min period. Plot the initial and 2-min readings of the force and deformation gages, measurement devices, or sensors in the form of load-deformation curves. Maintain complete load-deformation-time records throughout the test. If application of a given load is required for a certain period, such as 24 h, take deformation readings at the beginning, at intervals during this period, and at the end of this period, to allow the satisfactory plotting of a ~~time-deformation~~time-deformation curve for the complete period.

12.5.1 Reasons for 2-min application of constant-level increment loads are as follows:

12.5.1.1 To permit the assembly to come to a substantial rest prior to taking the second set of readings. (Depending on the method employed for applying the test load, it may be necessary to continue, at a reduced rate, the motion of the loading device in order to maintain the constant load level during the 2-min period.)

12.5.1.2 To provide sufficient time for making all observations. (Longer time intervals between loadings may be required under certain conditions.)

12.5.1.3 To observe any time-dependent deformation or load redistribution, or both, and to record accurately the load level when time-dependent deformation starts, that is, at the divergence of the immediate and delayed load-deformation curves. (This load level may, under certain conditions, have an important bearing on the design load.)

12.5.1.4 To be able to stop the test, if this should be desirable, prior to total failure, after initial failure has been anticipated as a result of the observations made.

12.5.1.5 To assure uniformity in test performance and consistency in test results.

12.6 *Rate of Loading*—The rate of loading between increments shall be uniform throughout the test and such that the load is applied at a constant rate of displacement of point of load application of 5.1 ± 2.5 mm (0.20 ± 0.10 in.)/min. If this rate of loading is not feasible because of the type of testing machine used or the field equipment available, the rate of loading shall be as near as is feasible to that required in this section.

13. Failure Analysis

13.1 *Slip at Failure*—Determine the maximum test load and the corresponding slip for each assembly tested to failure.

13.2 *Failure Modes*—Failure may occur by one mode or a combination of the following modes:

13.2.1 Failure of the total anchored railing system or rail.

13.2.2 Failure of the anchorage system.

13.2.3 Failure of the anchoring system: The yielding or fracture of any component or the anchoring devices, including hardware accessories, shall constitute failure.

13.2.4 Failure of the anchored railing system to return to the original or agreed-upon position after the application and release of the required test load.

14. Calculation

14.1 *Load-Slip Data*—Determine the unadjusted, adjusted, and appropriate average load-slip data for each loading period.

14.1.1 Calculate the unadjusted slips, ΔT and ΔS , at any given load for an individual test in the following manner. For tension tests, $\Delta T = \frac{1}{2}(A_n - A_1 + B_n - B_1)$, for shear and flexural tests, $\Delta S = A_n - A_1$, where A_n and B_n are instrument readings at a given load, and A_1 and B_1 are initial instrument readings as defined.

14.2 *Maximum Load Data*—Determine the average maximum load for a given assembly as the arithmetic mean of all maximum loads for a given test series.

15. Report

15.1 Report the applicable information as listed in Practice **E575** and indicated as follows:

15.1.1 Date of test and date of report,

15.1.2 Test sponsor and test agency,

15.1.3 Identification of anchored, anchoring, and anchorage systems. Manufacturers, models, types, materials, finishes, pretest curing, shapes, dimensions, and other pertinent information and observations such as cracks and other defects,

15.1.4 Description of the anchored, anchoring, and anchorage systems tested, including statement as to whether the test specimen was new or used or previously tested,

15.1.5 Detailed drawings or photographs of typical test assemblies before, during, and after testing, if not fully described otherwise,

15.1.6 Relevant physical strength properties of the anchored, anchoring, and anchorage materials used for test specimens,

15.1.7 Description of the procedure used for the assembly of the anchored, anchoring, and anchorage systems,

15.1.8 Age, in days, at time of test of the anchored, anchoring, and anchorage systems, if this information is of any significance,

15.1.9 Age, in hours or days, and description of any conditioning and curing since assembly of the anchored, anchoring, and anchorage systems, if this information is of any significance,

15.1.10 Species, oven-dry specific gravity, and moisture content at time of test, in oven-dry weight percent, of any wood anchorage members or components,