



Standard Test Method for Total Fluorine in Coal and Coke by Pyrohydrolytic Extraction and Ion Selective Electrode or Ion Chromatograph Methods¹

This standard is issued under the fixed designation D 5987; the number immediately following the designation indicates the year of original adoption or, in the case of revision, the year of last revision. A number in parentheses indicates the year of last reapproval. A superscript epsilon (ϵ) indicates an editorial change since the last revision or reapproval.

1. Scope

1.1 This test method covers the analysis of total fluorine in coal and coke.

1.2 This analysis was successfully tested on coals containing 37 % ash or less (see AS 1038.10.4 and Conrad²).

1.3 The values stated in SI units shall be regarded as standard. The values given in parentheses are for information only.

1.4 *This standard does not purport to address all of the safety concerns, if any, associated with its use. It is the responsibility of the user of this standard to establish appropriate safety and health practices and determine the applicability of regulatory limitations prior to use.* For specific hazard statements see Note 3 and Note 5.

1.5 All accountability and quality control aspects of Guide D 4621 apply to this test method.

2. Referenced Documents

2.1 ASTM Standards:

D 346 Practice for Collection and Preparation of Coke Samples for Laboratory Analysis³

D 1193 Specification for Reagent Water⁴

D 2013 Method for Preparing Coal Samples for Analysis³

D 2234 Methods for Collection of a Gross Sample of Coal³

D 3173 Test Method for Moisture in the Analysis Sample of Coal and Coke³

D 3180 Practice for Calculating Coal and Coke Analyses from As-Determined to Different Bases³

D 4621 Guide for Accountability and Quality Control in the Coal Analysis Laboratory³

D 5142 Test Methods for the Proximate Analysis of the Analysis Sample of Coal or Coke by Instrumental Procedures³

¹ This test method is under the jurisdiction of ASTM Committee D-5 on Coal and Coke and is the direct responsibility of Subcommittee D05.29 on Major Elements in Ash and Trace Elements of Coal.

Current edition approved July 10, 1996. Published September 1996.

² Conrad, V. B., and Brownlee, W. D., "Hydroxyrolytic—Ion Chromatographic Determination of Fluoride in Coal and Geological Materials," *Analytical Chemistry*, Vol 60, No. 4, 1988, pp. 365–369.

³ *Annual Book of ASTM Standards*, Vol 05.05.

⁴ *Annual Book of ASTM Standards*, Vol 11.01.

2.2 Australian Standard:⁵

AS 1038.10.4 Determination of Trace Elements—Coal, Coke and Fly-Ash—Determination of Fluorine Content—Pyrohydrolysis Method

3. Summary of Test Method

3.1 Total fluorine is determined in this test method by first subjecting the weighed test portion to pyrohydrolytic conditions which separate fluorine from the coal/coke matrix. The pyrohydrolysate is then gravimetrically processed and final determinations are made by either ion-selective electrode or ion chromatographic techniques.

4. Significance and Use

4.1 This test method permits measurement of the fluorine content of coal and coke for the evaluation of potential fluorine emission from coal combustion or conversion processes. When coal samples are combusted in accordance with this test method, the fluorine is quantitatively released from the coal and retained in the pyrohydrolysate so that it is representative of the total fluorine concentration in coal.

5. Apparatus

5.1 *Laboratory Ware*—Except as noted, all laboratory ware, for example, volumetric flasks, beakers, bottles, etc., used for solutions containing fluoride ions must be made of polyethylene, polystyrene, or a heat-resistant polymer such as polypropylene.

5.2 *Vials*—Glass or polystyrene, 10 to 30-mL capacity with tightly fitting snap-on plastic lids.

5.3 *Bottles*—Polypropylene, 125-mL capacity, wide-mouth, with liner-less leakproof polyethylene screw cap, for tube-furnace pyrohydrolysate processing.

5.4 *Vials*—Polystyrene, 70-mL capacity, with liner-less leakproof polyethylene screw cap.

5.5 *Dispensing Bottles*—Polyethylene, 250-mL capacity, for the standard fluorine solution (6.3.1) and of 600-mL capacity for the absorption solution (6.3.3) and buffer (6.3.5).

5.6 *Micropipettes*—Polypropylene or other suitable polymer, variable volumes ranging from 0.1 mL to at least 2.0 mL.

⁵ Available from American National Standards Institute, 11 W. 42nd St., 13th Floor, New York, NY 10036.

This is a satisfactory alternative to the 250-mL dispensing bottle (5.5), for the delivery of small volumes of the standard fluorine solution.

5.7 *Glass Dropper Bottle*—30-mL capacity for dispensing glacial acetic acid.

5.8 *Balance*—Analytical, with a sensitivity of 0.1 mg. The balance shall be checked periodically to determine its accuracy.

5.9 *Apparatus for Tube-Furnace Pyrohydrolysis* (see Fig. 1):

5.9.1 *Silica Tube-Furnace and Accessories:*

5.9.1.1 *Quartz Combustion Tube*—Translucent, pure silica (25-mm outside diameter, 20-mm inside diameter) of length appropriate to the particular furnace used. Preferably, the gas outlet end should be narrowed to a tubulure of approximately 7 mm in diameter.

NOTE 1—Combustion tubes of alternative refractory compositions do

not have adequate thermal stress characteristics for operation with this test method.

5.9.1.2 *Silicone Stoppers*—20 mm in diameter, positioned at inlet end and outlet, if applicable, of silica combustion tube (5.9.1.1).

5.9.1.3 *Combustion Boats*—Unglazed porcelain, high alumina content, approximately 97 mm by 16 mm by 12 mm, preheated at 1000°C for 1 h.

5.9.1.4 *Silica Pusher and T-Tube*—A silica push rod of dimensions 5 mm in diameter by 50 cm long, fused at one end to provide a flat disk surface of 10 to 12 mm in diameter and having a piece of magnetic steel affixed to the other end by epoxy resin. The T-tube, 50 cm long, is composed of borosilicate glass and protrudes 10 mm into the silica tube (5.9.1.1) through a stopper (5.9.1.2). A magnet is used to move the pusher inside the T-tube.

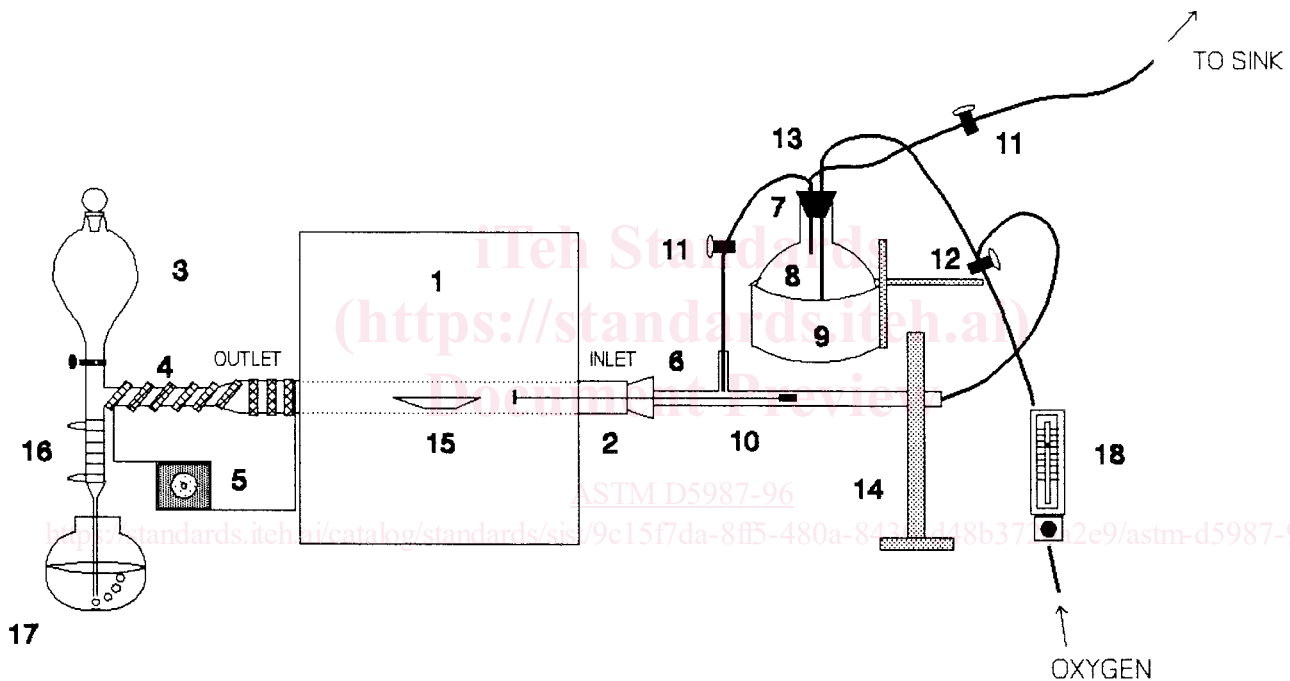

1. FURNACE (5.9.1e)
2. SILICA TUBE (5.9.1a)
3. SEPARATORY FUNNEL (5.9.3a)
4. HEATING TAPE (5.9.1f)
5. POWER REGULATOR (5.9.1f)
6. SILICONE STOPPER (5.9.1b)
7. RUBBER STOPPER
8. ROUND BOTTOM FLASK (5.9.2a)
9. HEATING MANTLE (5.9.2b)
10. BOROSILICATE T-TUBE AND SILICA PUSHER (5.9.1d)
11. STOPCOCKS (5.9.2e)
12. THREE-WAY STOPCOCK (5.9.2e)
13. Y-PIECE (5.9.2c)
14. RETORT STAND AND CLAMP
15. COMBUSTION BOAT (5.9.1c)
16. GRAHAM CONDENSER (5.9.3b)
17. RECEIVING FLASK (5.9.3c)
18. FLOWMETER (5.9.2f)

FIG. 1 Pyrohydrolysis Furnace and Fluorine Absorption Assembly

5.9.1.5 *Combustion Furnace*—Capable of reaching a maximum temperature of at least 1100°C.

5.9.1.6 *Heating Tape and Power Regulator*—To prevent condensation from forming in the outlet end of the combustion train.

5.9.2 *Steam Generator (Fig. 1)*:

5.9.2.1 *Round Bottom Flask*—Glass, 2-L capacity.

5.9.2.2 *Heating Mantle*—Of size sufficient to heat the round bottom flask (5.9.1.1).

5.9.2.3 *Y-piece*—Glass, 10 mm in diameter.

5.9.2.4 *Gas Distribution Tube*—Zero porosity.

5.9.2.5 *Stopcocks*—One three-way and one two-way.

5.9.2.6 *Flowmeter*—Capable of regulating and delivering at least 1000 mL/min of the oxygen.

5.9.3 *Absorption Vessel Components*:

5.9.3.1 *Separatory Funnel*—Glass, 125-mL capacity for rinsing Graham Condenser into receiving flask, with stopcock and 24/40 joint with drip tip.

5.9.3.2 *Graham Condenser*—For condensing hydroxyroly-sate, with 24/40 outer joint at top. Water jacket length should be 300 mm.

5.9.3.3 *Receiving Flask*—250-mL capacity, flat bottom, wide neck, and tooled mouth, for collection of pyrohydroly-sate.

5.10 *Ion-specific Electrode (ISE) Measurement Apparatus*:

5.10.1 *Specific Ion Meter*—A pH meter with an expandable millivolt scale sensitive to 0.1 mV, specific-ion meter or equivalent, suitable for method of standard addition determinations.⁶

5.10.2 *Electrodes*—Solid-state fluoride sensing, with the appropriate reference-type electrode as recommended by the manufacturer.

NOTE 2—The fluoride sensing element should be polished frequently and in accordance with the manufacturer's suggestions to prolong its optimal performance. <https://standards.iteh.ai/catalog/standards/sist/9c15f70c-2023-4100-9c15f70c-2023>

5.10.3 *Magnetic Stirrer*—Complete with polytetrafluoroethylene (PTFE) stirring bars and magnet for convenient removal of bars from vials.

5.11 *Ion-Chromatograph (IC)*—Equipped with three, 3 by 250-mm AS-3 anion separator columns and a fiber suppressor.⁷

6. Reagents

6.1 *Purity of Reagents*—Reagent grade chemicals shall be used in all tests. Unless otherwise indicated, it is intended that all chemicals shall conform to the specifications of the committee on Analytical Reagents of the American Chemical Society, where such specifications are available.⁸ Other grades may be used, provided it is first ascertained that the reagent is of sufficiently high purity to permit its use without lessening the accuracy of the determination.

⁶ Midgley, D., and Torrance, K., "Potentiometric Water Analysis," John Wiley and Sons, 1978.

⁷ Rice, T. D., *Analytica Chimica Acta*, 1983, 151, pp. 383–389.

⁸ *Reagent Chemicals, American Chemical Society Specifications*, American Chemical Society, Washington, DC. For suggestions on the testing of reagents not listed by the American Chemical Society, see *Analar Standards for Laboratory Chemicals*, BDH Ltd., Poole, Dorset, U.K., and the *United States Pharmacopeia and National Formulary*, U.S. Pharmacopeial Convention, Inc. (USPC), Rockville, MD.

6.2 *Reagent Water*—Reagent water conforming to type IV of Specification D 1193, shall be used in all cases unless otherwise indicated.

NOTE 3—**Warning:** Some reagents used in this test method are hazardous. Follow the precautions listed in the Material Safety Data Sheets of the manufacturer for each reagent.

6.3 *Solutions for ISE Test Method*:

6.3.1 *Standard Fluoride Solution* (1 g = 200 µg fluoride)—The following standard fluoride solutions are required:

6.3.1.1 *For Direct Comparison Method*—Dissolve 0.2210 ± 0.0002 g of dry (110°C for 1 h) sodium fluoride in approximately 400 mL of water in a 500-mL polypropylene beaker. Transfer by thorough rinsing with water to a 500-mL polypropylene volumetric flask. Dilute to mark with water and mix. Discard after one month.

NOTE 4—There will not be a classic meniscus in polypropylene volumetrics. The solution will correctly appear to have a flat surface.

6.3.1.2 *For Analyte-Addition Test Method*—Dissolve 0.2210 ± 0.0002 g of dry (110°C for 1 h) sodium fluoride in a 500-mL polypropylene beaker containing 150 mL of water and 250 mL of an unspiked buffered absorption solution (see 6.3.3). Transfer, by thorough rinsing with water, to a 500-mL polypropylene volumetric flask. Dilute with water to the mark and mix. Discard after one month (see Note 4).

6.3.2 *Absorption Solution* (0.025 M NaOH)—Dissolve 2.0 g of sodium hydroxide in about 500 mL of water. Transfer to a 2.0-L polypropylene flask, dilute to mark with water, and mix.

6.3.3 *Unspiked Buffered Absorption* (pH 6.5)—Dissolve 10.0 g of potassium nitrate, 2.0 g of sodium hydroxide, and 115 g of ammonium acetate in 1700 mL of water. Adjust pH to 6.5 with a small amount of glacial acetic acid. Transfer to a 2.0-L polypropylene flask, dilute to mark with water, and mix.

6.3.4 *Buffer Added After Tube-Furnace Hydrolysis* (pH 6.5)—Dissolve 10.0 g of potassium nitrate and 115 g of ammonium acetate in 350 mL of water. Adjust pH to 6.5 with a small amount of glacial acetic acid. Transfer to a 500-mL polypropylene volumetric flask, dilute to mark with water, and mix.

6.3.5 *Solution for Conditioning Fluoride ISE*—Using a pipette, transfer 20.0 mL of water, 20.0 mL of absorbing solution (6.3.2), and 10.0 mL of buffer (6.3.4) into a polystyrene vial (5.2). Add 200 µL of standard fluoride solution (6.3.1.1) and mix.

6.4 *Solutions for Ion-Chromatographic Measurement*:

6.4.1 *Standard Fluoride Solution* (1000 µg/mL fluoride)—Dissolve 2.2110 ± 0.0002 g of dry (105°C for 1 h) sodium fluoride in a 250-mL polypropylene beaker containing approximately 150 mL of water. Transfer with thorough rinses of water to a 1.0-L polypropylene volumetric flask. Dilute with water to the mark and mix (see Note 4).

6.4.2 *Standard Fluoride Solution* (1.0 µg/mL fluoride)—Transfer, by means of polypropylene pipette, 1.0 mL of standard fluoride solution (6.4.1) to a 1.0-L polypropylene volumetric flask; dilute to mark with water and mix (see Note 4). Prepare fresh solution daily.

6.4.3 *Sulfuric Acid, Standard* (2.5 N)—Cautiously dilute 71