



Standard Specification for Doors, Double, Gastight/Airtight, Individually Dogged, for Marine Use¹

This standard is issued under the fixed designation F1068; the number immediately following the designation indicates the year of original adoption or, in the case of revision, the year of last revision. A number in parentheses indicates the year of last reapproval. A superscript epsilon (ϵ) indicates an editorial change since the last revision or reapproval.

1. Scope

1.1 This specification, to be used in conjunction with Specification [F1073](#), covers the principal dimensions and the mechanical requirements for manufacturing steel and aluminum individually dogged, airtight/gastight double doors for personnel access through bulkheads, complete with frames, intended to maintain the structural and the air and gas tightness integrity of the bulkheads.

1.2 The values stated in inch-pound units are to be regarded as standard. The values given in parentheses are mathematical conversions to SI units that are provided for information only and are not considered standard.

1.3 The following precautionary caveat pertains only to the Test Methods portion, Section 6, of this specification: *This standard does not purport to address all of the safety concerns, if any, associated with its use. It is the responsibility of the user of this standard to establish appropriate safety, health, and environmental practices and determine the applicability of regulatory limitations prior to use.*

1.4 *This international standard was developed in accordance with internationally recognized principles on standardization established in the Decision on Principles for the Development of International Standards, Guides and Recommendations issued by the World Trade Organization Technical Barriers to Trade (TBT) Committee.*

2. Referenced Documents

2.1 *ASTM Standards:*²

[A36/A36M Specification for Carbon Structural Steel](#)
[A131/A131M Specification for Structural Steel for Ships](#)
[B209 Specification for Aluminum and Aluminum-Alloy Sheet and Plate](#)

¹ This specification is under the jurisdiction of ASTM Committee F25 on Ships and Marine Technology and is the direct responsibility of Subcommittee F25.03 on Outfitting and Deck Machinery.

Current edition approved April 1, 2018. Published May 2018. Originally approved in 1987. Last previous edition approved in 2012 as F1068 – 90 (2012). DOI: 10.1520/F1068-90R18.

² For referenced ASTM standards, visit the ASTM website, www.astm.org, or contact ASTM Customer Service at service@astm.org. For *Annual Book of ASTM Standards* volume information, refer to the standard's Document Summary page on the ASTM website.

[F1073 Specification for Door Fittings, for Watertight /Gastight /Airtight, Weathertight, and Non-Tight Doors, for Marine Use](#)

2.2 *ABS Standard:*³

[Rules for Building and Classing Steel Vessels](#)

2.3 *Military Standards:*⁴

[MIL-R-900 Rubber Gasket Material, 45 Durometer Hardness](#)

[MIL-C-81706 Coating, Aluminum and Aluminum Alloys](#)

[MIL-P-24441 Epoxy-Polyamide Paint](#)

[DoD-STD-2138 Metal Sprayed Coating System for Corrosion Protection](#)

[TT-E-490 Enamel, Silicone Alkyd Copolymer, Semi-Gloss, Exterior](#)

[ZZ-R-765 Rubber, Silicone](#)

3. Ordering Information

3.1 Ordering for doors under this specification shall include the following:

3.1.1 Material of doors,

3.1.2 Nominal and ASTM designations, fixed lights or no lights,

3.1.3 Quantity, and

3.1.4 Location of active and inactive panels.

3.2 Inspection and acceptance of doors shall be agreed upon between the purchaser and the supplier.

4. Construction, Shape, and Dimensions

4.1 The construction, shape, and clear opening dimensions shall be as shown in [Fig. 1](#) and [Table 1](#); in addition, they shall conform to the following requirements:

4.1.1 Door frames shall be supplied as indicated in [Fig. 1](#). The corner radius inside of door frame shall be 8 in. (203 mm).

4.1.2 Dogs shall be located on the door panels unless otherwise specified.

4.1.3 The doors shall be fitted with dogs, hinges, hasp and staple assemblies, grab handles, label plates, and hook assemblies.

³ Available from American Bureau of Shipping (ABS), ABS Plaza, 16855 Northchase Dr., Houston, TX 77060, <http://www.eagle.org>.

⁴ Available from DLA Document Services, Building 4/D, 700 Robbins Ave., Philadelphia, PA 19111-5094, <http://quicksearch.dla.mil>.

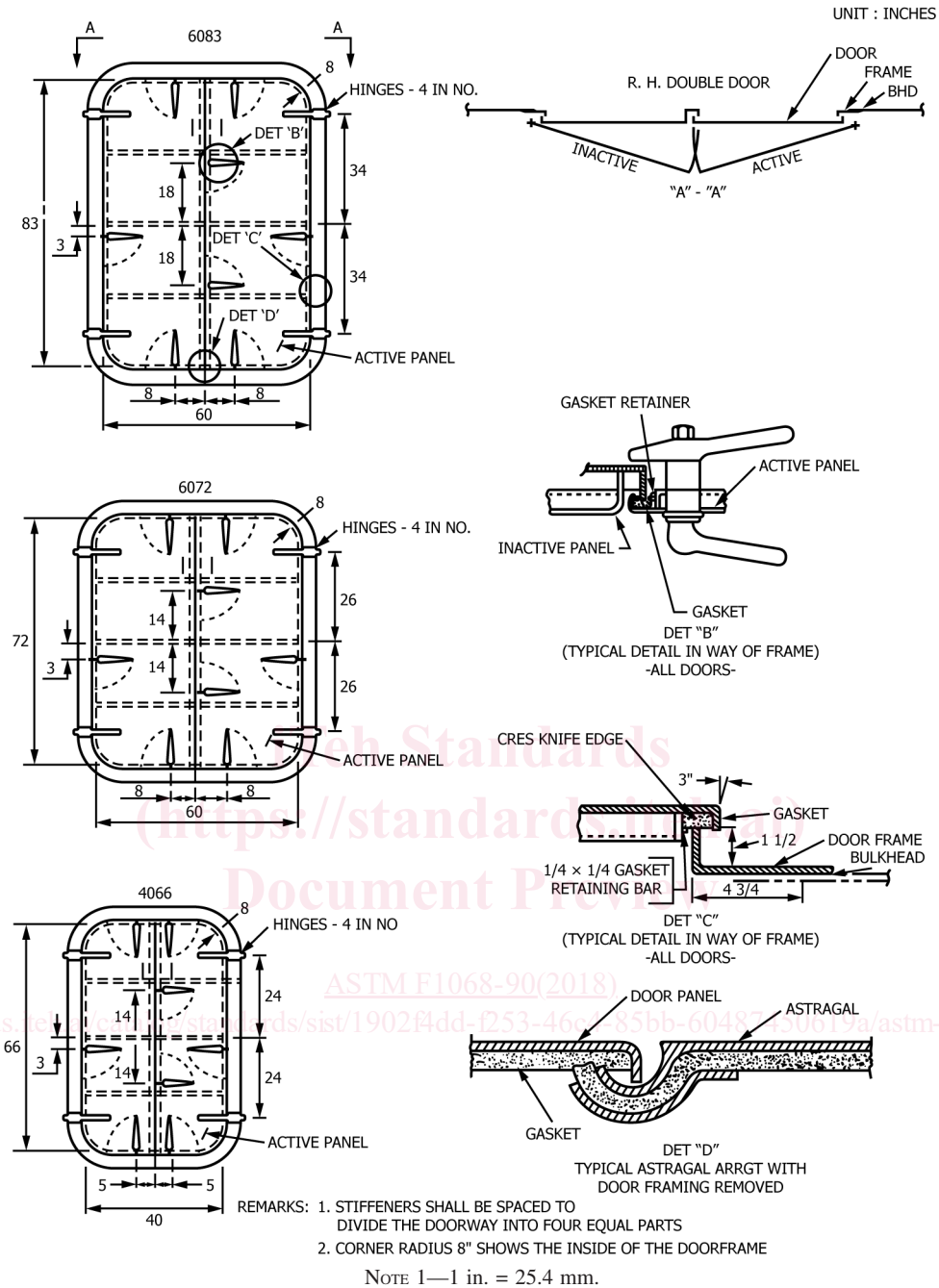

FIG. 1 Typical Double-Door Details

4.1.4 The position of the grab handles shall be located at the center of the height of each door panel.

4.1.5 The components shall be attached to the steel doors. Components shall be attached to aluminum doors by either welding or bolting.

4.1.6 The material of standard door components shall be as given in Table 2.

4.1.7 Welding shall be done in accordance with ABS Rules for Building and Classing Steel Vessels.

5. Workmanship, Finish, and Appearance

5.1 All sharp and ragged edges shall be ground flush and removed for personnel protection.

5.1.1 The door panels, upon completion, shall be straight with a tolerance of $\pm 1/16$ in. (1.6 mm).

5.2 Pretreatment and priming of door components shall be as follows:

5.2.1 Steel door and components, except component No. 3, are to be coated with inorganic zinc rich primer, SSPC Paint 20 Type I-C, at 1.5 to 3.0 mils (MDFT), both sides, before assembly, following surface preparation in accordance with the manufacturer's instructions.

5.2.2 Aluminum door and components, except component No. 3, are to be pretreated with vinyl wash primer coating, followed with lead free, chromate free, anti-corrosion prime