



Standard Specification for Warping Heads, Rope Handling (Gypsy Head, Capstan Head)¹

This standard is issued under the fixed designation F1106; the number immediately following the designation indicates the year of original adoption or, in the case of revision, the year of last revision. A number in parentheses indicates the year of last reapproval. A superscript epsilon (ϵ) indicates an editorial change since the last revision or reapproval.

1. Scope

1.1 This specification covers warping heads used with windlass, winch, and capstan drive units to pull rope on board ships. Warping heads are primarily for use with fiber rope, natural, or synthetic.

1.2 Warping heads with external ribs or whelps on the barrel, notched flanges, attached storage drums, unfinished drums, or non heat-treated fabrications, are considered special and are permitted within the scope of this specification when fully described under special ordering information.

1.3 The values stated in inch-pound units are to be regarded as standard. The values given in parentheses are mathematical conversions to SI units that are provided for information only and are not considered standard.

1.4 *This international standard was developed in accordance with internationally recognized principles on standardization established in the Decision on Principles for the Development of International Standards, Guides and Recommendations issued by the World Trade Organization Technical Barriers to Trade (TBT) Committee.*

2. Referenced Documents

2.1 ASTM Standards:²

[A27/A27M Specification for Steel Castings, Carbon, for General Application](#)

[A36/A36M Specification for Carbon Structural Steel](#)

[A53/A53M Specification for Pipe, Steel, Black and Hot-Dipped, Zinc-Coated, Welded and Seamless](#)

¹ This specification is under the jurisdiction of ASTM Committee F25 on Ships and Marine Technology and is the direct responsibility of Subcommittee F25.03 on Outfitting and Deck Machinery.

Current edition approved April 1, 2018. Published May 2018. Originally approved in 1987. Last previous edition approved in 2012 as F1106 – 87 (2012). DOI: 10.1520/F1106-87R18.

² For referenced ASTM standards, visit the ASTM website, www.astm.org, or contact ASTM Customer Service at service@astm.org. For *Annual Book of ASTM Standards* volume information, refer to the standard's Document Summary page on the ASTM website.

[A148/A148M Specification for Steel Castings, High Strength, for Structural Purposes](#)

[A501 Specification for Hot-Formed Welded and Seamless Carbon Steel Structural Tubing](#)

[A724/A724M Specification for Pressure Vessel Plates, Carbon-Manganese-Silicon Steel, Quenched and Tempered, for Welded Pressure Vessels](#)

[A735/A735M Specification for Pressure Vessel Plates, Low-Carbon Manganese-Molybdenum-Columbium Alloy Steel, for Moderate and Lower Temperature Service \(Withdrawn 2017\)³](#)

[E10 Test Method for Brinell Hardness of Metallic Materials](#)

2.2 *AWS Standard:*⁴

D1.1 *Structural Welding Code*

2.3 *ANSI Standard:*⁵

ASA B46.1 *Surface Texture*

2.4 *Military Standards:*⁶

Fed-Spec T-R-605 *Manila, Three Strand*

MIL-R-24050 *Nylon, Double Braided*

3. Terminology

3.1 *Definitions of Terms Specific to This Standard:*²⁰¹⁸

3.1.1 *barrel*—cylindrical or conical midbody portion of a warping head.

3.1.1.1 *Discussion*—The barrel may have a uniform diameter through the length or may be tapered from one end to the other.

3.1.2 *flanges*—circumferential rims at the ends of the barrel used to retain wraps of rope on the barrel portion of the warping head.

³ The last approved version of this historical standard is referenced on www.astm.org.

⁴ Available from American Welding Society (AWS), 8669 NW 36 St., #130, Miami, FL 33166-6672, <http://www.aws.org>.

⁵ Available from American National Standards Institute (ANSI), 25 W. 43rd St., 4th Floor, New York, NY 10036, <http://www.ansi.org>.

⁶ Available from U.S. Government Printing Office, Superintendent of Documents, 732 N. Capitol St., NW, Washington, DC 20401-0001, <http://www.access.gpo.gov>.

3.1.3 *rope contact surfaces*—portions of the barrel, flanges, and connecting fillets that a rope will contact when led in tangent to the barrel and normal to the shaft centerline, wrapped around the barrel, and led away tangent to the barrel as in normal use. (See Fig. 1 and Fig. 2.)

3.1.4 *warping head (also known as a gypsy head or capstan head)*—cylindrical or conical rotating member to receive multiple wraps of rope around the circumference of the member and of suitable strength to impart a pulling motion to the rope by friction contact when the member is rotated.

4. Classification

4.1 The size of the warping head shall be identified by the nominal barrel diameter measured at the smallest point of the barrel.

4.2 Warping heads under this specification are furnished in two types as follows:

4.2.1 *Type I Warping Head With Cylindrical Barrel*—Generally used in but not restricted to horizontal shaft applications. Also known as a gypsy head (see Fig. 1).

4.2.2 *Type II Warping Head With a Conical Barrel*—Mounted with the large end of the barrel toward the drive machinery. Generally used in but not restricted to vertical shaft applications. Also known as a capstan head (see Fig. 2).

4.3 Warping heads are divided into four grades as follows:

4.3.1 *Grade 1*—Fabricated from any combination of structural steel plate, pipe, tubing, or steel castings and joined by electric welding.

4.3.2 *Grade 2*—Cast from mild to medium strength steel.

4.3.3 *Grade 3*—Fabricated from any combination of steel plate or steel castings and joined by electric welding. Heat treated to provide a surface hardness (1/8 in. (3 mm) deep) of 200 to 250 Brinell on rope contact surface. Rope contact surface finished to an average 125 to 160-μin. (3175 to 4064-μmm) finish.

4.3.4 *Grade 4*—Cast from high strength steel castings and heat treated to provide a surface hardness (1/8 in. (3 mm) deep) of 200 to 250 Brinell on rope contact surface. Rope contact surface finished to an average 125 to 160-μin. (3175 to 4064-μmm) finish.

4.4 When required by ordering information, an accessory cover will be provided to cover the open end of the warping head.

5. Ordering Information

5.1 Orders for warping heads under this specification shall include the following:

- 5.1.1 Quantity (number),
- 5.1.2 ASTM designation and year of issue,
- 5.1.3 Size (barrel diameter),
- 5.1.4 Type (I or II),
- 5.1.5 Grade (1, 2, 3, or 4),
- 5.1.6 As-cast or machined dimensions for warping head bore, hub length and location, hub puller holes, and shaft keying,
- 5.1.7 Requirement for optional accessory cover on open end of warping head (see 4.4),

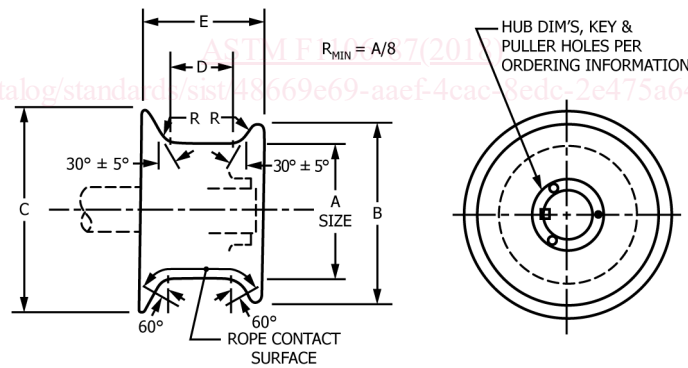

A Diameter, in.	Rope Pull, 1000 lb	B Diameter, in.	C Diameter, in.	D Length, in.	E Length, in.	Tolerance, in. ± ^A	Concentricity, in. ^B
6	12.5	8	9 1/16	2 3/4	5 15/32	1/4	1/8
9	25.0	12	13 5/8	4 1/16	8 3/16		
12	37.5	16	18 3/16	5 7/16	10 31/32		
15	50.0	20	22 3/4	6 3/4	13 11/16	1/2	1/4
18	75.0	24	27 5/16	8 1/16	16 13/32		
21	100.0	28	31 7/8	9 7/16	19 3/16	5/8	5/16
24	125.0	32	36 3/8	10 13/16	21 7/8		
27	150.0	36	41 15/16	12 3/16	24 31/32		
30	175.0	40	45 1/2	13 1/2	27 3/8	3/4	3/8
33	200.0	44	50 1/16	14 13/16	30 3/32		
36	225.0	48	54 3/8	16 3/16	32 7/8	7/8	7/16

^A Tolerance for dimensions A, B, C, D, and E.
^B Concentricity of rope contact surface and flanges relative to bore.

NOTE 1—1 in. = 25.4 mm.

FIG. 1 Type I Warping Head