

INTERNATIONAL STANDARD

NORME INTERNATIONALE

AMENDMENT 1
AMENDEMENT 1

Low-voltage fuses – **STANDARD PREVIEW**
Part 6: Supplementary requirements for fuse-links for the protection of solar
photovoltaic energy systems
(standards.iteh.ai)

Fusibles basse tension – [IEC 60269-6:2010/AMD1:2021](https://standards.iteh.ai/catalog/standards/sist/06c3ca19-122d-4052-bdfe-311111111111)
Partie 6: Exigences supplémentaires concernant les éléments de remplacement
utilisés pour la protection des systèmes d'énergie solaire photovoltaïque





THIS PUBLICATION IS COPYRIGHT PROTECTED

Copyright © 2021 IEC, Geneva, Switzerland

All rights reserved. Unless otherwise specified, no part of this publication may be reproduced or utilized in any form or by any means, electronic or mechanical, including photocopying and microfilm, without permission in writing from either IEC or IEC's member National Committee in the country of the requester. If you have any questions about IEC copyright or have an enquiry about obtaining additional rights to this publication, please contact the address below or your local IEC member National Committee for further information.

Droits de reproduction réservés. Sauf indication contraire, aucune partie de cette publication ne peut être reproduite ni utilisée sous quelque forme que ce soit et par aucun procédé, électronique ou mécanique, y compris la photocopie et les microfilms, sans l'accord écrit de l'IEC ou du Comité national de l'IEC du pays du demandeur. Si vous avez des questions sur le copyright de l'IEC ou si vous désirez obtenir des droits supplémentaires sur cette publication, utilisez les coordonnées ci-après ou contactez le Comité national de l'IEC de votre pays de résidence.

IEC Central Office
3, rue de Varembe
CH-1211 Geneva 20
Switzerland

Tel.: +41 22 919 02 11
info@iec.ch
www.iec.ch

About the IEC

The International Electrotechnical Commission (IEC) is the leading global organization that prepares and publishes International Standards for all electrical, electronic and related technologies.

About IEC publications

The technical content of IEC publications is kept under constant review by the IEC. Please make sure that you have the latest edition, a corrigendum or an amendment might have been published.

IEC publications search - webstore.iec.ch/advsearchform

The advanced search enables to find IEC publications by a variety of criteria (reference number, text, technical committee, ...). It also gives information on projects, replaced and withdrawn publications.

IEC online collection - oc.iec.ch

Discover our powerful search engine and read freely all the publications reviews. With a subscription you will always have access to up to date content tailored to your needs.

IEC Just Published - webstore.iec.ch/justpublished

Stay up to date on all new IEC publications. Just Published details all new publications released. Available online and once a month by email.

Electropedia - www.electropedia.org

The world's leading online dictionary on electrotechnology, containing more than 22 000 terminological entries in English and French with equivalent terms in 18 additional languages. Also known as the International Electrotechnical Vocabulary (IEV) online.

IEC Customer Service Centre - webstore.iec.ch/csc

If you wish to give us your feedback on this publication or need further assistance, please contact the Customer Service Centre: sales@iec.ch.

A propos de l'IEC

La Commission Electrotechnique Internationale (IEC) est la première organisation mondiale qui élabore et publie des Normes internationales pour tout ce qui a trait à l'électricité, à l'électronique et aux technologies apparentées.

A propos des publications IEC

Le contenu technique des publications IEC est constamment revu. Veuillez vous assurer que vous possédez l'édition la plus récente, un corrigendum ou amendement peut avoir été publié.

Recherche de publications IEC -

webstore.iec.ch/advsearchform

La recherche avancée permet de trouver des publications IEC en utilisant différents critères (numéro de référence, texte, comité d'études, ...). Elle donne aussi des informations sur les projets et les publications remplacées ou retirées.

IEC online collection - oc.iec.ch

Découvrez notre puissant moteur de recherche et consultez gratuitement tous les aperçus des publications. Avec un abonnement, vous aurez toujours accès à un contenu à jour adapté à vos besoins.

IEC Just Published - webstore.iec.ch/justpublished

Restez informé sur les nouvelles publications IEC. Just Published détaille les nouvelles publications parues. Disponible en ligne et une fois par mois par email.

Electropedia - www.electropedia.org

Le premier dictionnaire d'électrotechnologie en ligne au monde, avec plus de 22 000 articles terminologiques en anglais et en français, ainsi que les termes équivalents dans 16 langues additionnelles. Egalement appelé Vocabulaire Electrotechnique International (IEV) en ligne.

Service Clients - webstore.iec.ch/csc

Si vous désirez nous donner des commentaires sur cette publication ou si vous avez des questions contactez-nous: sales@iec.ch.

INTERNATIONAL STANDARD

NORME INTERNATIONALE

AMENDMENT 1
AMENDEMENT 1

Low-voltage fuses – **STANDARD PREVIEW**
Part 6: Supplementary requirements for fuse-links for the protection of solar photovoltaic energy systems
(standards.iteh.ai)

Fusibles basse tension – **IEC 60269-6:2010/AMD1:2021**
Partie 6: Exigences supplémentaires concernant les éléments de remplacement utilisés pour la protection des systèmes d'énergie solaire photovoltaïque

INTERNATIONAL
ELECTROTECHNICAL
COMMISSION

COMMISSION
ELECTROTECHNIQUE
INTERNATIONALE

ICS 29.120.50

ISBN 978-2-8322-9631-8

Warning! Make sure that you obtained this publication from an authorized distributor.
Attention! Veuillez vous assurer que vous avez obtenu cette publication via un distributeur agréé.

FOREWORD

This amendment has been prepared by subcommittee 32B: Low-voltage fuses, of IEC technical committee 32: Fuses.

The text of this amendment is based on the following documents:

FDIS	Report on voting
32B/698/FDIS	32B/699/RVD

Full information on the voting for the approval of this amendment can be found in the report on voting indicated in the above table.

The committee has decided that the contents of this amendment and the base publication will remain unchanged until the stability date indicated on the IEC website under "http://webstore.iec.ch" in the data related to the specific publication. At this date, the publication will be

- reconfirmed,
- withdrawn,
- replaced by a revised edition, or
- amended.

iTeh STANDARD PREVIEW
(standards.iteh.ai)

<https://standards.iteh.ai/catalog/standards/sist/06c3ca19-122d-4052-bdfe-f001ce046f0f/iec-60269-6-2010-amd1-2021>

1.1 Scope and object

Replace the first two sentences of the Scope with the following new text:

These supplementary requirements apply to fuse-links for protecting PV strings and PV arrays in equipment for circuits of nominal voltages up to 1 500 V DC, and also, in so far as they are applicable, for circuits of higher nominal voltages.

1.2 Normative references

Delete the date and the footnote after the following reference:

IEC 60269-1

Add the following new references:

IEC 61386-1, *Conduit systems for cable management – Part 1: General requirements*

IEC 61730-2, *Photovoltaic (PV) module safety qualification – Part 2: Requirements for testing*

IEC 62548, *Photovoltaic (PV) arrays – Design requirements*

IEC 60364-7-712, *Low voltage electrical installations – Part 7-712: Requirements for special installations or locations – Solar photovoltaic (PV) power supply systems*

2 Terms and definitions

2.2 General terms

Add, after the title of 2.2, the following new note:

NOTE Photovoltaic = PV.

2.2.101

Replace the existing title and text of 2.2.101 with the following new title and text:

2.2.101

PV fuse-link

2.2.101.1

PV fuse-link (general)

fuse-link capable of breaking, under specified conditions, any current value within the breaking range

NOTE A PV fuse-link operates under two main conditions:

- Short-circuit in a string (see IEC 62548 and IEC 60634-7-712 or in an array or sub-array (see IEC 62548 and IEC 60634-7-712) which leads to a very low over-current.
- Short-circuit current supplied by the discharge of the PV inverter through a very low inductance. This condition leads to a very high rate of rise of current equivalent to a low value of time constant, corresponding to Table 104.

iTeh STANDARD PREVIEW
(standards.iteh.ai)

2.2.101.2

PV string fuse-link

fuse-link for the short-circuit and overload protection in a string

[IEC 60269-6:2010/AMD1:2021](https://standards.iteh.ai/catalog/standards/sist/06c3ca19-122d-4052-bdfe-60269-6-2010-amd1-2021)

2.2.101.3

<https://standards.iteh.ai/catalog/standards/sist/06c3ca19-122d-4052-bdfe-60269-6-2010-amd1-2021>

sub-array or array or array field fuse-link

fuse-link for the short-circuit and cable overload protection in an sub-array or array or array field

2.2.101.4

functional earthing fuse-link

fuse-link for earthing circuit protection of the photovoltaic (or PV) arrays. Functional earthing fuse-link arrangement can be found in IEC 60364-7-712 and IEC 62548

2.2.102

Delete existing Subclause 2.2.102.

2.2.103

Delete existing Subclause 2.2.103.

2.2.104

Delete the words “array field, assembly, generator, panel” from the text of Subclause 2.2.104 and renumber 2.2.104 to 2.2.102 and 2.104.1 to 2.2.102.1

Delete Subclauses 2.2.104.2, 2.2.104.3, 2.2.104.4 and 2.2.104.5.

Renumber 2.2.104.6 as 2.2.102.2 and 2.2.104.7 as 2.2.102.3.

2.2.105

Delete Subclause 2.2.105.

2.2.106

Delete Subclause 2.2.106.

2.2.107

Renumber 2.2.107 as 2.2.102.4.

2.2.108

Renumber 2.2.108 as 2.2.102.5.

2.2.109

Renumber 2.2.109 as 2.2.103 and replace the existing text with the following new text:

2.2.103

currents

2.2.103.1

short circuit current

(symbol I_{SC}), (unit:A)

electric current at the output terminals of a PV device at a particular temperature and irradiance, when the device output voltage is equal or close to zero

2.2.103.2

maximum overcurrent rating

$I_{MOD_MAX_OCPR}$

PV module maximum overcurrent protection rating determined by IEC 61730-2

2.2.103.3

short circuit current of a PV module

$I_{SC\ MOD}$

short circuit current of a PV module or PV string at standard test conditions (STC), as specified by the manufacturer

2.2.103.4

short circuit current of an array

$I_{SC\ ARRAY}$

short-circuit current of the PV array at standard test conditions (STC), which is equal to $I_{SC\ ARRAY} = I_{SC\ MOD} \times N_S$ where N_S is the total number of parallel-connected PV strings in the PV array

NOTE 1 A PV string is a number of PV modules connected in series. The short circuit current of a string is equal to $I_{SC,MOD}$.

2.2.103.5

short circuit current of an sub-array

$I_{SC\ S-ARRAY}$

short circuit current of a PV sub-array at standard test conditions (STC), which is equal to $I_{SC\ S-ARRAY} = I_{SC\ MOD} \times N_{SA}$ where N_{SA} is the number of parallel-connected PV strings in the PV sub-array

2.2.103.6

maximum reverse current of an array

(symbol I_{RM}) (unit: A)

maximum reverse current accepted by the module or the panel

2.2.110

Renumber 2.2.110 as 2.2.104.

Replace, in the title of 2.2.110, "photovoltaic" by "PV".

Delete Subclauses 2.2.110.1, 2.2.110.2, 2.2.110.3 and 2.2.110.4.

Renumber 2.2.110.5 as 2.2.104.1 and replace "output electrical current" by "load current".

Renumber 2.2.110.6 as 2.2.104.2.

Delete Subclause 2.2.110.7.

Table 101 – Conventional times and currents for “gPV” fuse-links

Replace existing Table 101 with the following new table:

Table 101 – Conventional times and currents for "gPV" fuse-links

Rated current <i>A</i>	Conventional time <i>h</i>	Conventional current		Fuse type
		Type "gPV"		
		<i>I_{nf}</i>	<i>I_f</i>	
$I_n \leq 63$	1 2	1,05 -	- 1,35 ¹⁾	String fuse-link
$63 < I_n \leq 160$	2	-	-	Subarray or Array fuse-link
$160 < I_n \leq 400$	3	1,13*	1,45*	
$400 < I_n$	4	-	-	

NOTE 1) For $I_f = 1,35 I_n$ the operating time is 2 h (The thermal withstand capability of a PV module under reverse current is qualified during a 2 h test specified in module safety test from IEC 61730 and is specified on the module as the "maximum overcurrent protection" value).

* The use of these values for conventional currents is not permitted in North America. String fuse-link conventional current values are permitted for sub-array and array fuse-links

8.3.3 Measurement of power dissipation of the fuse-link

Add the following new sentence at the end of the second paragraph of 8.3.3:

This test maybe performed with either alternating or direct current.

8.4.3.1 Verification of conventional non-fusing and fusing current

Replace the existing first sentence of 8.4.3.1 with the following new sentence:

It is permissible to make the following tests at a reduced voltage and either alternating or direct current.

Replace existing bullet point b) with the following new text:

- b) The fuse-link is subjected to the conventional fusing current. It shall operate within the conventional time (Table 101). For string fuse-links it is also acceptable when $I_f = 1,35 I_n$ when the fuse link operates within $t_c = 2$ hours as specified in Table 101, Note 2. The fuse-link shall operate without external effects or damage.

NOTE If this test arrangement is not applicable, special tests shall be performed according to the manufacturer's instructions and all pertinent data shall be recorded in the test report.

8.4.3.2 Verification of rated current

Replace the existing text of 8.4.3.2 with the following new text:

The test requested in 8.4.3.2 of IEC 60269-1:2006 is replaced by the following. The requirements for safe operation apply from IEC 60 269-1, 8.5.8:2006.

The tests may be performed with either alternating or direct current at reduced voltage.

a) String fuse-links:

Rated current ≤ 63 A: Three samples are to undergo 3 000 repetitions of current cycling where one cycle is represented in Figure 101. None of the samples shall exhibit cracking of the fuse body. This test may be performed with either alternating or direct current.

After this test, the resistance of the fuse-link at room temperature shall not have changed by more than 10 %, and then tests presented in 8.11.2.4 and Tables 102 and 103 shall be made.

b) Sub array and Array fuse-links, rated current > 63 A (these fuse-links protect cables):

The test required in 8.4.3.2 of IEC 60269-1:2006 is applicable with the following modifications:

One fuse-link is submitted to a pulse test for 100 h, in which the fuse-link will be cyclically loaded. Each cycle with an on-period of the conventional time and an off-period of 0,1 of the conventional time, the test current being equal to 0,85 of the rated current of the fuse-link.

After the test the fuse-link shall not have changed its characteristics. Verification shall be carried out by the test as described in item a) of 8.4.3.1.

This test may be performed with either alternating or direct current.

[IEC 60269-6:2010/AMD1:2021](https://standards.iteh.ai/catalog/standards/sist/06c3ca19-122d-4052-bdfe-f001ce046f0f/iec-60269-6-2010-amd1-2021)

<https://standards.iteh.ai/catalog/standards/sist/06c3ca19-122d-4052-bdfe-f001ce046f0f/iec-60269-6-2010-amd1-2021>

Table 104 – Values for breaking capacity tests on “gPV” fuse-links

Replace the existing text of the cell concerning time constant for test No.5 with the following new text:

≤ 1 ms

Figure 101 – Current of test cycling

Replace existing Figure 101 with the following new Figure 101:

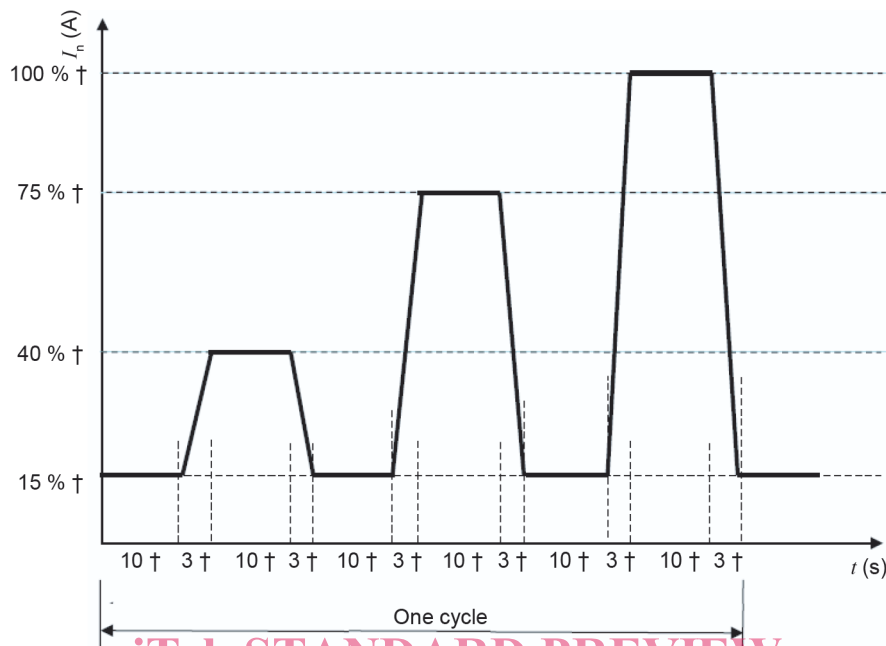

iTeh STANDARD PREVIEW
 (standards.iteh.ai)
 † Current: 100 % = $(100 \begin{smallmatrix} 0 \\ -5 \end{smallmatrix})\%$ Time 10 s = $(10 \begin{smallmatrix} +2 \\ 0 \end{smallmatrix})\text{s}$
 75 % = $(75 \begin{smallmatrix} 0 \\ -5 \end{smallmatrix})\%$ 3 s = $(3 \begin{smallmatrix} 0 \\ -3 \end{smallmatrix})\text{s}$
 40 % = $(40 \begin{smallmatrix} 0 \\ 5 \end{smallmatrix})\%$
 15 % = $(15 \begin{smallmatrix} 0 \\ -5 \end{smallmatrix})\%$
 IEC 60269-6:2010/AMD1:2021
<https://standards.iteh.ai/catalog/standards/sist/06c3ca19-122d-4052-bdfe-f001ce046f0f/iec-60269-6-2010-amd1-2021> IEC

Annex AA – Examples of standardized fuse-links for the protection of solar photovoltaic energy systems

AA.1 General

Delete the words “French”, “North American” and “DIN” after the bullet points for systems type A, type B and type C.

Replace the existing fourth bullet point with the following new text:

- system of long fuse-links with blade contacts, type D (Figure AA.5)

Add, after the fourth bullet point, the following new text:

- Replacement handle for fuse links type D – Figure AA.6
- Examples of fuse bases to AA.5 (long fuse links with blade contacts) – Figure AA.7
- System of long fuse links with bolted contacts – Figure AA.7

Replace the last two paragraphs of Clause AA.1 with the following new text:

In addition to making these requirements of this standard, the power dissipation of the fuse-link shall not exceed the acceptable power acceptance of the associated fuse-bases or fuse-holders.

Where the power dissipation of the fuse link exceeds the acceptable power acceptance of the standardised fuse-base or fuse-holder, de-rating values shall be given by the manufacturer.

Figure AA.1 – Fuse-links with cylindrical contact caps, type A

Replace the existing table in the key to Figure AA.1 with the following new table:

Size	<i>a</i>	<i>b</i> _{max}	<i>c</i>	<i>d</i> _{min}	<i>r</i>
10 x 38	38+0,9/-0,6	10,5	10,3+/-0,1	6	1,5+/-0,5
14 x 51	51+0,6/-1 ³⁾	13,8	14,3+/-0,1	7,5	2+/-1
10 x 85	85+/-1,2	10,5	10,3+/-0,1	6	1,5+/-0,5
20 x 127	127+/-2 ³⁾	16,2	20,6+/-0,2	10,8	2+/-1
22 x 127	127+/-2 ³⁾	16,2	22,2+/-0,2	11	2+/-1
27 x 140	140+/-2	16,2	27,0+/-0,2	15,9	2+/-1

AA.3 North American cylindrical fuse-links with blade contacts, type B (specific for PV application)

Replace the existing title of Clause AA.3 with the following new title:

iTeh STANDARD PREVIEW

AA.3 Cylindrical fuse-links with blade contacts, type B (specific for PV application)

Figure AA.3 – North American cylindrical fuse-links with blade contacts – Sizes 61-600 A

Replace the existing title of Figure AA.3 with the following new title:

Figure AA.3 – Cylindrical fuse-links with blade contacts – Sizes 61-600 A

AA.4 Fuse-links with blade contacts, type C, C referring IEC 60269-2 "Fuse system A (NH fuse system)"

Figure AA.4 – Fuse-links with blade contacts, type C, C referring IEC 60269-2 "Fuse system A (NH fuse system)"

Replace existing Figure AA.4 with the following new Figure AA.4:

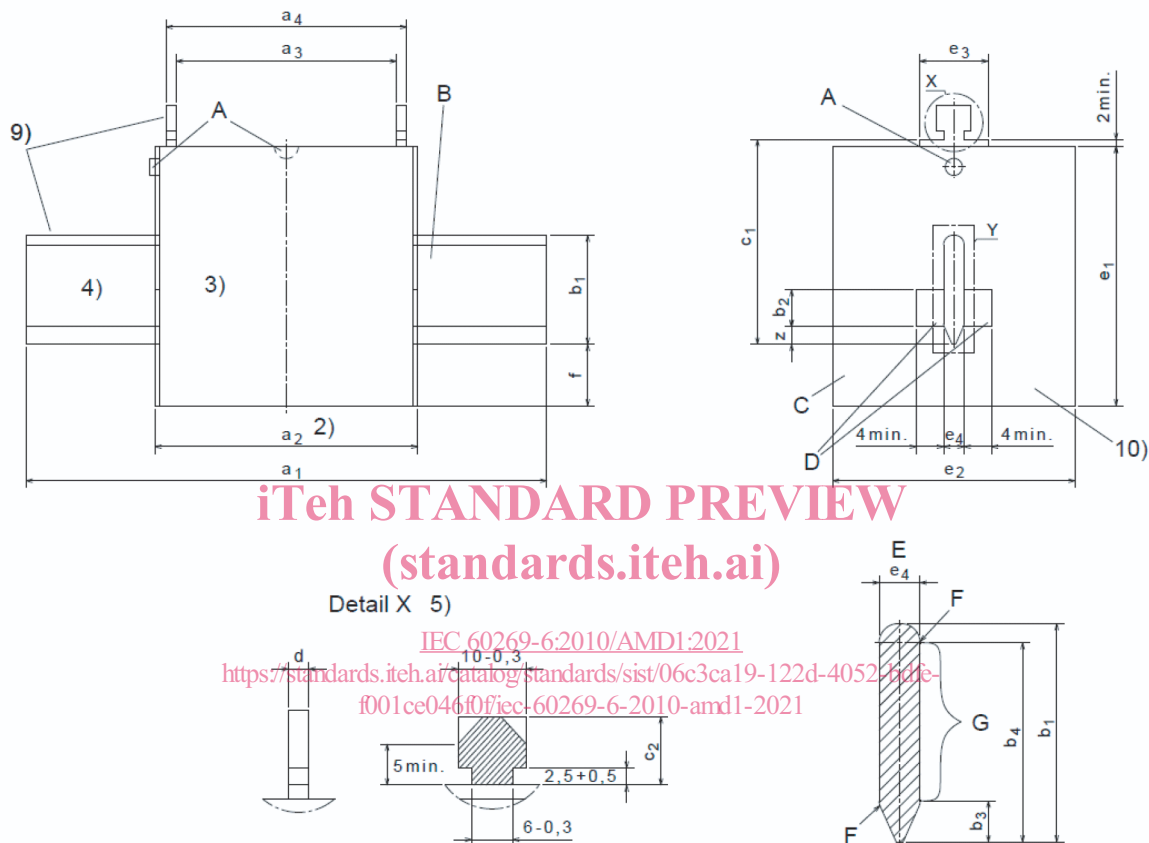

IEC

Key

- A indicating device (see ⁸⁾)
- B contact
- C endplate
- D stop face
- E detail Y (sectional view)
- F rounded (see ¹²⁾)
- G contact face

Size	a_1	a_2	a_3	a_4	b_1 min.	b_2 min.	b_3 max.	b_4 min.	c_1 $\pm 0,8$	c_2	d	e_1 max.	e_2 max.	e_3	e_4 $\pm 0,2$	f max.	z max.
	1)	2)	1)	1)	11)	11)	11)	11)			5)	6)	6)				
1	135 $\pm 2,5$	75 -10	62 $\pm 2,5$	68 $\pm 2,5$	20	5	6	17	40	11	2,5 +1,5 -0,5	53	52	20	6	15	5
2	150 $\pm 2,5$	75 -10	62 $\pm 2,5$	68 $\pm 2,5$	25	8	6	22	48	11	2,5 +1,5 -0,5	61	60	20	6	15	5
3	150 $\pm 2,5$	75 -10	62 $\pm 2,5$	68 $\pm 2,5$	32	11	6	29	60	11	2,5	76	75	20	6	18	5

												+1,5							
												-0,5							

Dimensions in millimeters

- 1) The centres of the dimensions a_1 , a_3 and a_4 shall not deviate from the centre of a_2 by more than 1,5 mm.
- 2) The dimension a_2 shall be observed within the total area of the stop faces ($b_2 \times 4$ min.) on both sides of the blades. Outside of these areas the maximum dimension a_2 applies.
- 3) Insulating material.
- 4) The blade contacts shall be axially aligned and contact surfaces shall be plane.
- 5) Attachment for replacement handle (detail X).
- 6) Maximum dimensions of the enclosure of the fuse-link. Within these limits, the fuse-links may be of any form, for example, square, rectangular, circular, oval, polygonal, etc.
- 8) Indicating device. Position of the indicating device as chosen by the manufacturer.
- 9) Live parts, gripping-lugs can be insulated.
- 10) With the exception of the attachment for the replacement handle (detail X), the endplates are not permitted to protrude radially from the insulation body.
- 11) As far as overlapping of rated currents exists within the sizes 1, 2 and 3 the dimension of the smaller size is permitted.
- 12) All corners shall be rounded to prevent damage to the contact surface of the base contacts.

**ITEH STANDARD PREVIEW
(standards.iteh.ai)**

IEC 60269-6:2010/AMD1:2021
<https://standards.iteh.ai/catalog/standards/sist/06c3ca19-122d-4052-bdfe-f001ce046f0f/iec-60269-6-2010-amd1-2021>