



Designation: **D4180 – 13** **D4180 – 13 (Reapproved 2018)**

# Standard Test Method for Vibratory Packing Density of Formed Catalyst Particles and Catalyst Carriers<sup>1</sup>

This standard is issued under the fixed designation D4180; the number immediately following the designation indicates the year of original adoption or, in the case of revision, the year of last revision. A number in parentheses indicates the year of last reapproval. A superscript epsilon ( $\epsilon$ ) indicates an editorial change since the last revision or reapproval.

## 1. Scope

1.1 This test method covers the determination of the vibratory packing density of formed catalyst and catalyst carriers. For the purpose of this test, catalyst particles are defined as extrudates, spheres, or formed pellets of 0.8 to 4.8-mm ( $1/32$  to  $3/16$ -in.) nominal diameter.

1.2 The values stated in SI units are to be regarded as the standard. The values given in parentheses are for information only.

1.3 *This standard does not purport to address all of the safety concerns, if any, associated with its use. It is the responsibility of the user of this standard to establish appropriate ~~safety~~ safety, health, and ~~health~~ environmental practices and determine the applicability of regulatory limitations prior to use.*

1.4 *This international standard was developed in accordance with internationally recognized principles on standardization established in the Decision on Principles for the Development of International Standards, Guides and Recommendations issued by the World Trade Organization Technical Barriers to Trade (TBT) Committee.*

## 2. Referenced Documents

2.1 *ASTM Standards:*<sup>2</sup>

[D3766 Terminology Relating to Catalysts and Catalysis](#)

[E177 Practice for Use of the Terms Precision and Bias in ASTM Test Methods](#)

[E456 Terminology Relating to Quality and Statistics](#)

[E691 Practice for Conducting an Interlaboratory Study to Determine the Precision of a Test Method](#)

[E1272 Specification for Laboratory Glass Graduated Cylinders](#)

## 3. Terminology

3.1 *Definitions*—See Terminology [D3766](#).

## 4. Summary of Test Method

4.1 A preconditioned sample of formed catalyst or catalyst carrier is vibrated in a cylinder. The vibratory packing density is determined from a known mass and vibrated volume.

## 5. Significance and Use

5.1 This test method is to be used for measuring the vibratory packing density of formed particles that will not break up during sampling, filling, or vibrating of the measuring cylinder under test conditions.

<sup>1</sup> This test method is under the jurisdiction of ASTM Committee [D32](#) on Catalysts and is the direct responsibility of Subcommittee [D32.02](#) on Physical-Mechanical Properties.

Current edition approved Dec. 1, 2013; May 1, 2018. Published December 2013; May 2018. Originally approved in 1988. Last previous edition approved in 2008 as [D4180 – 03 \(2008\)](#); [D4180 – 13](#). DOI: [10.1520/D4180-13](#); [10.1520/D4180-13R18](#).

<sup>2</sup> For referenced ASTM standards, visit the ASTM website, [www.astm.org](#), or contact ASTM Customer Service at [service@astm.org](#). For *Annual Book of ASTM Standards* volume information, refer to the standard's Document Summary page on the ASTM website.

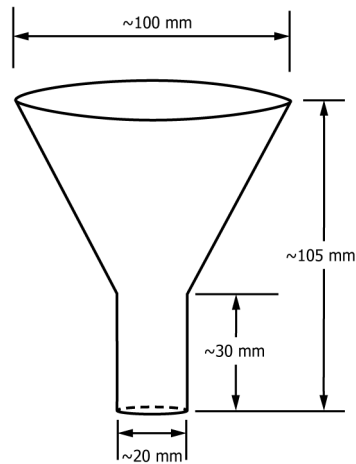

FIG. 1 Feed Funnel

## 6. Apparatus

- 6.1 *Glass Cylinders*, capacity 250 mL, feed and measuring, conforming to Specification E1272, Class A.
- 6.2 *Vibrator*,<sup>3</sup> conventional handheld, with hard rubber or metal impactor.
- 6.3 *Feed Funnel*, plastic, glass, or metal as shown in Fig. 1.
- 6.4 *Ring Stand, Vibrator Holder and Clamps* as shown in Figs. 2 and 3.
- 6.5 *Desiccator*, with a desiccant grade molecular sieve such as a No. 4A.
- 6.6 *Balance* having sensitivity of 0.1 g.

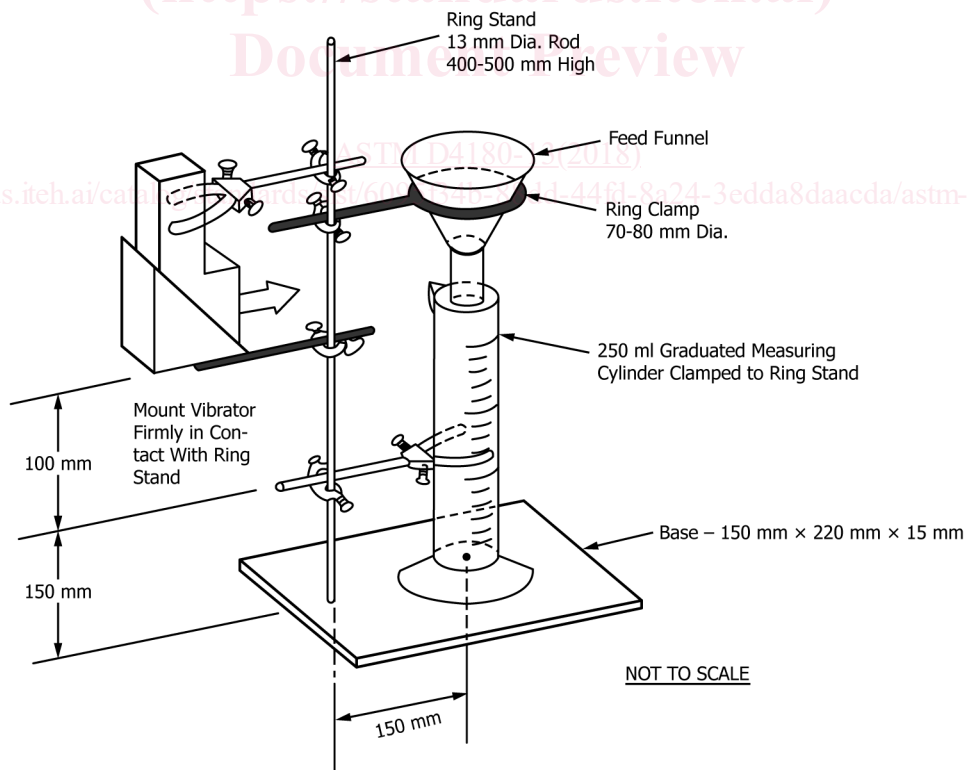

FIG. 2 Assembly of Apparatus

<sup>3</sup> The sole source of supply of the vibrator known to the committee at this time is Wahl Clipper Corp., Sterling, IL. Model 4120 used at low speed is recommended to replace Model 4180, which is discontinued. If you are aware of alternative suppliers, please provide this information to ASTM International Headquarters. Your comments will receive careful consideration at a meeting of the responsible technical committee,<sup>1</sup> which you may attend.