



Designation: **D4520 – 13 D4520 – 18**

Standard Practice for Determining Water Injectivity Through the Use of On-Site Floods¹

This standard is issued under the fixed designation D4520; the number immediately following the designation indicates the year of original adoption or, in the case of revision, the year of last revision. A number in parentheses indicates the year of last reapproval. A superscript epsilon (ϵ) indicates an editorial change since the last revision or reapproval.

1. Scope*

1.1 This practice covers a procedure for conducting on-site core flood tests to determine the filtration and chemical treatment requirements for subsurface injection of water.^{2, 3}

1.2 This practice applies to water disposal, secondary recovery, and enhanced oil recovery projects and is applicable to injection waters with all ranges of total dissolved solids contents.

1.3 The values stated in SI units are to be regarded ~~separately~~ as standard. The values ~~stated given in each system parentheses~~ are mathematical conversions and may not be exact equivalents; therefore, each system shall be used independently of the other to inch-pound units that are provided for information only and are not considered standard.

1.4 *This standard does not purport to address all of the safety concerns, if any, associated with its use. It is the responsibility of the user of this standard to establish appropriate ~~safety~~ safety, health, and ~~health~~ environmental practices and determine the applicability of regulatory limitations prior to use.*

1.5 *This international standard was developed in accordance with internationally recognized principles on standardization established in the Decision on Principles for the Development of International Standards, Guides and Recommendations issued by the World Trade Organization Technical Barriers to Trade (TBT) Committee.*

2. Referenced Documents

2.1 ASTM Standards:⁴

[D420 Guide for Site Characterization for Engineering Design and Construction Purposes](#)

[D653 Terminology Relating to Soil, Rock, and Contained Fluids](#)

[D1129 Terminology Relating to Water](#)

[D2434 Test Method for Permeability of Granular Soils \(Constant Head\) \(Withdrawn 2015\)⁵](#)

[D4404 Test Method for Determination of Pore Volume and Pore Volume Distribution of Soil and Rock by Mercury Intrusion Porosimetry](#)

2.2 American Petroleum Institute-API Standards:⁶

[API RP27 Recommended Practice for Determining Permeability of Porous Media](#)

[API RP40 Recommended Practice for Core-Analysis Procedure](#)

3. Terminology

3.1 Definitions:

3.1.1 ~~For definitions of terms relating to water and water chemistry, refer to Terminology D1129. Refer to Terminology D653 for definitions relating to soil and rock~~

3.1 Definitions:

¹ This practice is under the jurisdiction of ASTM Committee D19 on Water and is the direct responsibility of Subcommittee D19.05 on Inorganic Constituents in Water. Current edition approved Jan. 1, 2013; May 1, 2018. Published February 2013; June 2018. Originally approved in 1986. Last previous edition approved in 2008 as [D4520 – 03 \(2008\); D4520 – 13](#). DOI: [10.1520/D4520-13.10.1520/D4520-18](#).

² Farley, J. T., and Redline, D. G., "Evaluation of Flood Water Quality in the West Montalvo Field," *Journal Petroleum Technology*, July 1968, pp. 683–687.

³ McCune, C. C., "On-Site Testing to Define Injection Water Quality Requirements," *Journal Petroleum Technology*, January 1977, pp. 17–24. McCune, C. C., "On-Site Testing to Define Injection Water Quality Requirements," *Journal Petroleum Technology*, January 1977, pp. 17–24.

⁴ For referenced ASTM standards, visit the ASTM website, [www.astm.org](#), or contact ASTM Customer Service at [service@astm.org](#). For *Annual Book of ASTM Standards* volume information, refer to the standard's Document Summary page on the ASTM website.

⁵ The last approved version of this historical standard is referenced on [www.astm.org](#).

⁶ Available from American Petroleum Institute (API), 1220 L. St., NW, Washington, DC 20005-4070, [http://www.api.org](#).

*A Summary of Changes section appears at the end of this standard

3.1.1 For definitions of terms relating to water and water chemistry, refer to Terminology **D1129**. For definitions of terms relating to soil and rock, refer to Terminology **D653**.

3.2 Definitions of Terms Specific to This Standard:

3.2.1 *filtration requirement, n*—the maximum suspended solids size (in micrometres) allowed in an injection water to minimize formation plugging.

3.2.2 *test core, n*—a sample cut from a full-core that has been recovered from the formation into which water is injected.

3.2.3 *permeability, n*—the capacity of a rock (or other porous medium) to conduct liquid or gas; permeability is measured as the proportionality constant between flow velocity and hydraulic gradient.

3.2.4 *pore volume, n*—the porous medium's void-volume that can be saturated with the transmitted fluid.

3.2.5 *porosity, n*—the ratio (usually expressed as a percentage) of the volume of voids of a given soil, rock mass, or other porous medium to the total volume of the soil, rock mass, or other porous medium.

3.2.6 *rock-water interaction, n*—a reaction between a porous rock and the injected water causing precipitation or swelling or release of fines (clays) within the rock.

4. Summary of Practice

4.1 This practice assumes that the injection water has been characterized in terms of dissolved and suspended solids contents (including hydrocarbons and other organics as applicable) by established standard practices and methods.

4.2 Test core material is selected by consultation between geologists and engineers and prepared for the tests by standard practices.

4.3 In the on-site core flood the permeability of the test core is monitored to detect interactions between the formation rock and the injection water. The water is filtered at various levels to determine the filtration required (in micrometres) to minimize permeability loss (damage) from suspended solids. Backflowing injection wells are simulated by reversing the flow direction through the cores.

5. Significance and Use

5.1 The injectivity of a water is best determined by measurements as near to the well as possible to minimize changes in water properties due to air contact and time. This practice describes how core flow tests are carried out near the well.

5.2 This practice permits the differentiation of permeability losses from the effects of chemical interaction of water and rock and from the effects of plugging by suspended solids. The procedure can be utilized to estimate the chemical and filtration requirements for the full-scale injection project.

5.3 Application of the test results to injection wells requires consideration of test core selection and geometry effects.

5.4 This practice as described assumes that the water does not contain free oil or other immiscible hydrocarbons. The presence of free oil would require the method to be modified to account for the effect of oil saturation in the test cores on the water permeability.

6. Sources of Rock-Water Interactions

6.1 Water injected into a porous rock may interact with the rock to reduce the permeability as a result of the formation of precipitates, clay swelling, clay dispersion, or the migration of other fine solids.

6.2 Rock-water interactions are more common in sandstones than in carbonate rocks. However, within carbonate rocks dissolved iron in the injection water may precipitate especially in the presence of dissolved oxygen. Alkaline precipitates (CaCO_3 and $\text{Mg}(\text{OH})_2$) may also form in carbonate rocks.

6.2.1 Dissolved hydrogen sulfide in the presence of dissolved iron and oxygen can also be a problem in waters injected into carbonate and sandstones resulting in precipitation of sulfides and hydroxides of iron.

6.3 The iron and alkaline precipitates described in 6.2 can also form from waters injected into sandstones. Swelling type clays (montmorillonite and mixed layer clays) and dispersible clays (kaolinite and chlorite) are potential sources of permeability losses due to changes in salinity or ionic content of the injected water compared to the natural waters in the formation. In some sandstones fine mica particles have been caused to migrate by the injection of a potassium ion deficient water.

6.4 In some instances in both sandstones and carbonates some fine particles are released to migrate as a result of water saturating the cleaned and dried test cores.

7. Apparatus

7.1 A schematic diagram of the test apparatus is shown in **Fig. 1**. The component parts are assembled from commercially available laboratory apparatus with the exception of the core holders (**Fig. 2**). While four cores are shown in **Fig. 1** the number

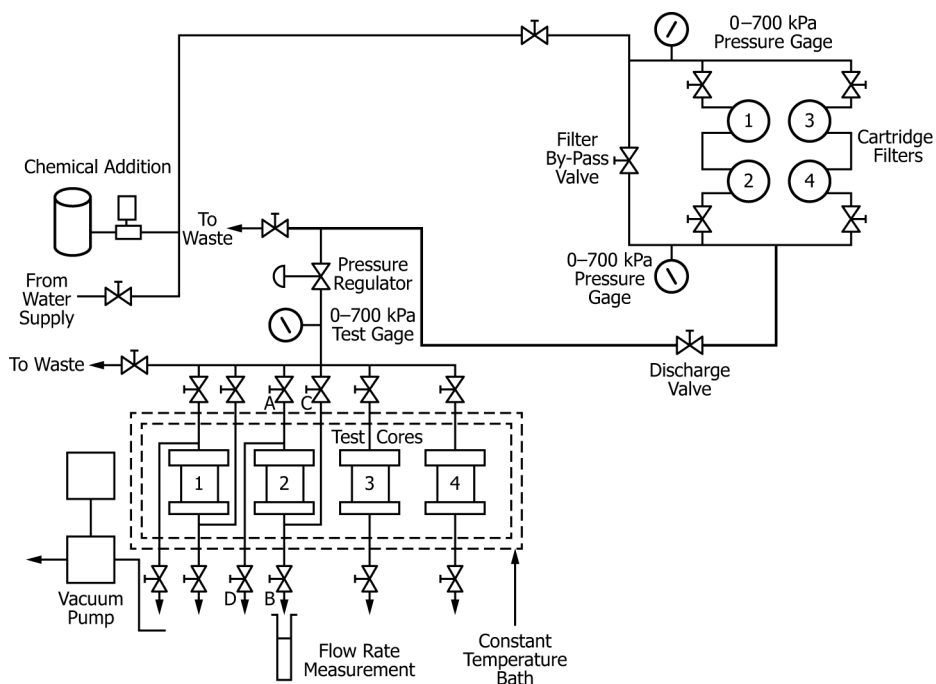

FIG. 1 Schematic of Test Equipment

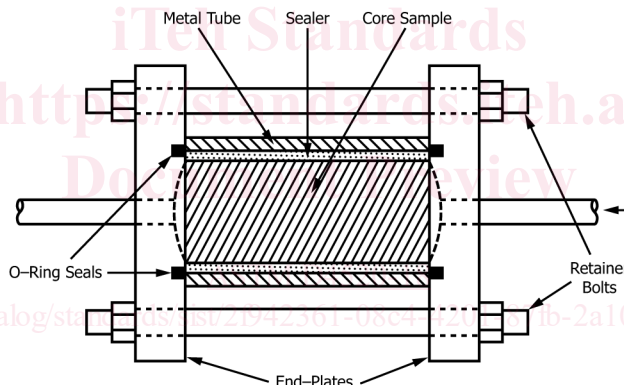

FIG. 2 Schematic Diagram of Sample Holder

used in a test is optional. The apparatus essentially consists of a filtration section and a core flood section. The various components are connected with plastic or stainless steel flow lines with required valves and gauges as illustrated.

7.2 The filtration section is assembled from four cartridge filter holders mounted two each in series. Valves are installed to permit flow through either filter pair or to bypass the filters. Pressure gauges are included for monitoring the inlet and discharge pressure of the filters. Commercial filters are available with ratings ranging as low as 0.2 μm . The rated sizes used in the on-site core flood tests generally range from 0.45 to 10 μm . The filter holders should be provided with vents to saturate the filters and purge air from the system.

7.3 The core flood section of the apparatus consists of a laboratory constant temperature bath rated for up to 150°C (302°F) and of adequate capacity to hold up to four core holders (Fig. 2). Necessary valves and gauges are provided. As shown in Fig. 1, two of the core holders (No. 1 and No. 2) are plumbed to allow the flow through the cores to be reversed without removing the core holders. The pressure to the core flood section is controlled with a regulator, and a test gauge is used to accurately monitor the test core inlet pressure. The test core discharge pressure is atmospheric when the apparatus is assembled as shown in Fig. 1.

7.3.1 Another option is to control the discharge at a pressure above atmospheric by the addition of a regulator on each core sample discharge line. This option is recommended if the evolution of dissolved gas is anticipated from the water as it flows through the test core.

7.4 An alternative to the core holders (Fig. 2) is a Hassler-type permeability cell (API RP40) which uses a rubber or plastic sleeve to form the seal around the core sample. A high-pressure air (nitrogen) or liquid supply to maintain the seal would be required.

7.5 The operating gauge pressure of the test apparatus is usually 700 kPa (100 psig) or less.

7.6 As shown in Fig. 1, facilities may also be provided for the addition of chemicals to the water being tested. A chemical supply tank and an injection pump with pressure and flow ratings corresponding to specific needs would be required.

7.7 The apparatus is attached to a line carrying the water being tested. Usually, the line pressure of the water source (regulated as required) satisfies the pressure requirement for flowing the water through the filters and test cores. If the supply pressure is insufficient, a small pump capable of delivering about 1 L/min at 700 kPa is used.

7.8 Other required apparatus are the following:

7.8.1 Mechanical (non-aspirator type) vacuum pump,

7.8.2 Assorted beakers (250 to 1000 mL),

7.8.3 Assorted graduated cylinders (10 to 100 mL),

7.8.4 Stopwatch,

7.8.5 Vacuum tubing, and

7.8.6 Assorted tools for assembling and disassembling the equipment as required.

8. Procedure

8.1 *Core Selection:*

8.1.1 Choose proper core samples to yield the most meaningful test results through close coordination with geologists, chemists, and engineers responsible for the water injection project.

8.1.2 To assist in that choice include well logs, mineralogy, porosity, pore size distribution, permeability, and other core descriptive data.

8.1.3 Choose test cores to represent the zones that will receive the injected water. The best samples are from whole cores cut from those zones. Prepare sufficient samples to represent the ranges of permeability, porosity, and mineralogy of the injected zones. Consider the presence of natural fractures.

8.1.4 Select the number and properties of the cores for a particular test according to one of the following options:

8.1.4.1 Use cores having similar properties (porosity, permeability, mineralogy, etc.). Average the results.

8.1.4.2 Use a set of cores with one of these properties different in each core to test the effect of this property on the test results.

8.1.5 If cores from the flooded zone are not available, choose another zone with similar properties as the next best alternative sample source. As a third choice use synthetic core material (alumina, silica, porous glass, etc.).

Document Preview

[ASTM D4520-18](#)

<https://standards.iteh.ai/catalog/standards/sist/2f942361-08c4-4201-87fb-2a100101e408/astm-d4520-18>