



Designation: F2826 – 14 (Reapproved 2018)

# Standard Test Method for Evaluating the Sustained Air Performance and Exhaust Emission Efficiencies of Central Vacuum Cleaning Units<sup>1</sup>

This standard is issued under the fixed designation F2826; the number immediately following the designation indicates the year of original adoption or, in the case of revision, the year of last revision. A number in parentheses indicates the year of last reapproval. A superscript epsilon ( $\epsilon$ ) indicates an editorial change since the last revision or reapproval.

## 1. Scope

1.1 This test method is a laboratory test for determining the sustained air performance and Exhaust Emissions of a central vacuum cleaner when tested under laboratory conditions.

1.2 This test method is applicable to all central vacuum cleaners with or without any type of internal filter. This test method is intended to help indicate how performance may be affected after multiple times of vacuuming over an extended period of time.

1.3 The inch-pound system of units is used in this standard except for weight measurements, which are measured in grams. The values stated in parentheses are given for information only.

1.4 *This standard does not purport to address all of the safety concerns, if any, associated with its use. It is the responsibility of the user of this standard to establish appropriate safety, health, and environmental practices and determine the applicability of regulatory limitations prior to use.*

1.5 *This international standard was developed in accordance with internationally recognized principles on standardization established in the Decision on Principles for the Development of International Standards, Guides and Recommendations issued by the World Trade Organization Technical Barriers to Trade (TBT) Committee.*

## 2. Referenced Documents

### 2.1 ASTM Standards:<sup>2</sup>

- E1 Specification for ASTM Liquid-in-Glass Thermometers
- E177 Practice for Use of the Terms Precision and Bias in ASTM Test Methods
- E691 Practice for Conducting an Interlaboratory Study to Determine the Precision of a Test Method

<sup>1</sup> This test method is under the jurisdiction of ASTM Committee F11 on Vacuum Cleaners and is the direct responsibility of Subcommittee F11.22 on Air Performance.

Current edition approved May 1, 2018. Published June 2018. Originally approved in 2014. Last previous edition approved in 2014 as F2826 – 14. DOI: 10.1520/F2826-14R18.

<sup>2</sup> For referenced ASTM standards, visit the ASTM website, [www.astm.org](http://www.astm.org), or contact ASTM Customer Service at [service@astm.org](mailto:service@astm.org). For *Annual Book of ASTM Standards* volume information, refer to the standard's Document Summary page on the ASTM website.

F820 Test Method for Measuring Air Performance Characteristics of Central Vacuum Cleaning Systems

2.2 ISO Standard:<sup>3</sup>

ISO 5011 Inlet Air Cleaning Equipment for Internal Combustion Engines and Compressors—Performance Testing

## 3. Terminology

### 3.1 Definitions:

3.1.1 *exhaust emissions*—measure of the efficiency of a unit to capture the loading media. Exhaust Emissions is  $(1 - (\text{the weight of the media exhausted into the exhaust emissions bag, divided by the weight of the media introduced}) \times 100)$ .

3.1.2 *input power, W, n*—the rate at which electrical energy is absorbed by a vacuum cleaner motor/fan system.

3.1.3 *model, n*—the designation of a group of vacuum cleaner systems having the same mechanical and electrical construction.

3.1.4 *population, n*—the total of all units of a particular model vacuum cleaner system being tested.

3.1.5 *sample, n*—a group of vacuum cleaner systems taken from a large collection of vacuum cleaner systems of one particular model, which serves to provide information that may be used as a basis for making a decision concerning the larger collection.

3.1.6 *seal vacuum*—a water lift reading for a power unit when the inlet is entirely closed or sealed.

3.1.7 *standard air density,  $\rho_{std}$ , lb/ft<sup>3</sup>, n*—atmospheric air density of 0.075 lb/ft<sup>3</sup> (1.2014 Kg/m<sup>3</sup>).

3.1.7.1 *Discussion*—This value of air density corresponds to atmospheric air at a temperature of 68°F (20°C), 14.696 psi (101.325 kPa), and approximately 30 % relative humidity.

3.1.8 *suction, inches of water, n*—in a vacuum cleaner system, the absolute difference between ambient and sub-atmospheric pressure.

3.1.9 *sustained air performance, n*—the ability of a vacuum cleaner to maintain air performance with a known quantity of media aspirated into unit throughout a number of feeding cycles.

<sup>3</sup> Available from International Organization for Standardization (ISO), 1, ch. de la Voie-Creuse, CP 56, CH-1211 Geneva 20, Switzerland, <http://www.iso.org>.

3.1.10 *test run, n*—the definitive procedure that produces the singular result.

3.1.11 *test station pressure, B<sub>p</sub>, inches of mercury, n*—for a vacuum cleaner system, the absolute barometric pressure at the test location (elevation), and test time.

3.1.11.1 *Discussion*—It is not the equivalent mean sea level value of barometric pressure typically reported by the airport and weather bureaus. It is sometimes referred to as the uncorrected barometric pressure (that is, not corrected to the mean sea level equivalent value).

3.1.12 *unit, n*—a single vacuum cleaner system of the model being tested.

3.1.13 *working vacuum*—a water lift reading value at an orifice causing a vacuum equivalent to a standard cleaning tool applied to the floor or rug.

**4. Significance and Use**

4.1 The test results allow comparison of sustained air performance of central vacuum cleaners that employ various methods of separating the dirt from the air used to convey the dirt to the central power unit. The results will be expressed as a percentage of the original vacuum performance after loading a prescribed weight of media.

4.2 The test results will allow a comparison of emissions by measuring the media emitted during the test and expressing this as an Exhaust Emissions.

**5. Apparatus**

5.1 *Water Manometer, or equivalent instruments*, to provide measurements from 0 to 150 in. (3810 mm) of water in increments of 0.1 in. (2.5 mm).

5.2 *Wattmeter*, to provide measurements accurate to within ±1 %.

5.3 *Voltmeter*, to provide measurements accurate to within ±1 %.

5.4 *Barometer*, with an accuracy of ±0.05 in. (1.27 mm) Hg, with scale divisions 0.02 in. (0.51 mm) or finer.

5.5 *Thermometer*, solid stem thermometer having a range from 18 to 89°F (8 to 32°C) with gradation of 0.2°F (0.1°C) increments and conforming to the requirements for thermometer 63°F or 63°C as prescribed in Specification E1.

5.6 *Voltage Regulator System*, to control the input voltage to the vacuum cleaner motor/fan system. The regulator system shall be capable of maintaining the vacuum cleaner’s rated voltage ±1 % and rated frequency ±1 Hz having a wave form that is essentially sinusoidal with 3 % maximum harmonic distortion for the duration of the test.

5.7 *Weighing Scale (for weighing media)*, accurate to 0.0035 oz. (0.1 g) and having a weighing capacity of at least 1000 g.

NOTE 1—All available scales may not be suitable for this test method. Any scale considered for use in this test method shall be checked for suitability in accordance with the requirements listed above.

5.8 *Stop Watch/Clock*, with a second hand or other type of equipment capable of establishing the specified rate of movement and total cycle time.

5.9 *Suction Fixture*, used to feed test media and make vacuum readings. The suction fixture will be used for feeding the media and measuring the vacuum by interchanging the feed tube and manometer tube. (See Fig. 1.)

5.10 *Emissions Collection Bag*, minimum 6 gal capacity, 15.2 mill disposable filter bag with a minimum quality of the following features: 98.4 % dust retention of particle sizes down to and including 0.3 microns (as tested per ISO 5011), an air permeability rating of 239 L/m<sup>2</sup>-s, an initial pressure loss of 480 Pa, and a 277 kPa burst strength. (For units without an

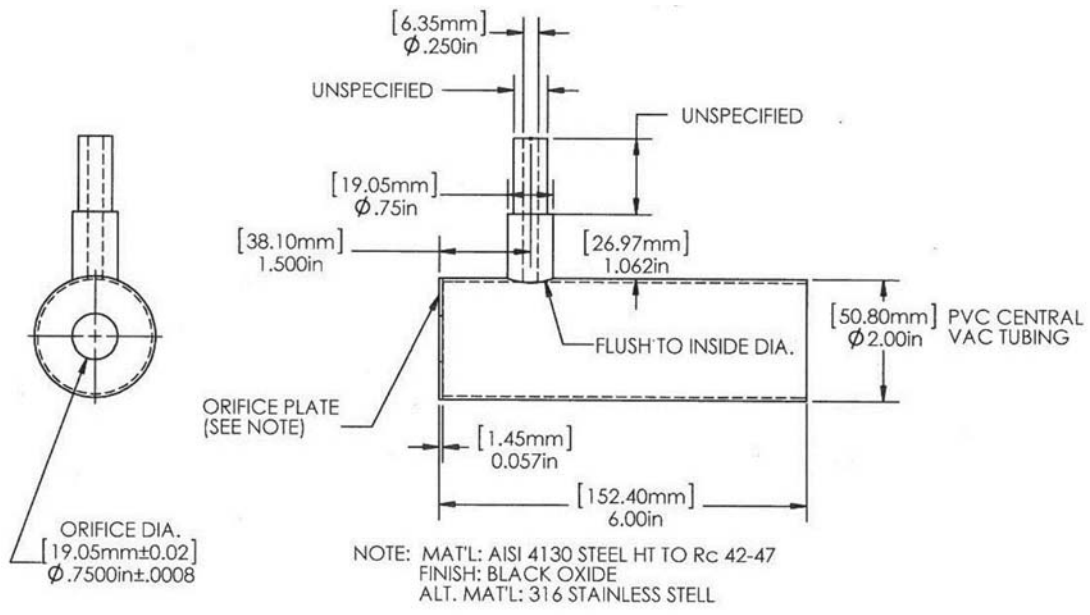

**SUCTION FIXTURE**

**FIG. 1 Suction Fixture**

integral discharge tube, a non-permeable shroud shall be fitted over the discharge area such that all emissions are routed into the emissions bag.)

**6. Sampling**

6.1 A minimum of three units of the same model central vacuum cleaner system, selected at random in accordance with good statistical practice, shall constitute the population sample.

6.1.1 To determine the best estimate of the sustained air performance and Exhaust Emissions for the population of the central vacuum cleaner system model being tested, the arithmetic mean of the Sustained Air Performance and Exhaust Emissions of the sample from the population shall be established by testing it to a 90 % confidence level within  $\pm 5$  % of the calculated mean.<sup>4</sup>

6.2 Annex A1 provides a procedural example for determining the 90 % confidence level and when the sample size shall be increased.

**7. Materials**

7.1 *Medial*—Commercial grade talcum.

**8. Conditioning**

8.1 *Test Room*—The test room shall be maintained at  $70 \pm 5$ °F ( $21 \pm 3$ °C) and 45 to 55 % relative humidity.

8.2 All components involved in the test shall remain and be exposed in the controlled environment for at least 16 h prior to the start of the test.

<sup>4</sup> Two sources of the talcum (USP Grade Supreme Talc) known to the committee at this time are Fischer Scientific Co., 1600 West Glen Avenue, Box 171, Itasca, IL 60143 and Luzenac America (Rio Tinto Minerals), 8051 E. Maplewood Ave., Building 4, Greenwood Village, CO 80111.

**9. Preparation for Test**

9.1 *New Test Central Vacuum Systems:*

9.1.1 *Preconditioning a New Central Vacuum System*—Run the system in a rated voltage  $\pm 1$  % and rated frequency  $\pm 1$  Hz with filters in place for 1 h. Unit is to run in at full open orifice during preconditioning period.

9.1.2 For systems with non-disposable filters, weigh and record the filter’s original weight to the nearest 0.0035 oz (0.1 g). This may not be possible with some systems in which the non-disposable filter cannot be removed.

9.2 *Used Test Central Vacuum Systems:*

9.2.1 Recondition a used test central vacuum system prior to each test run as follows:

9.2.1.1 Thoroughly remove excess dirt from the test central vacuum system. Without using tools for disassembly, clean the entire outer surface, ductwork, and inside of the chamber surrounding any and all filters (disposable or not).

9.2.1.2 For systems using disposable filters, use new disposable filter(s) for each test. Thoroughly clean the inside of the chamber surrounding the primary filter each time the filter is replaced.

9.2.1.3 For systems using cloth filter bags or other types of non-disposable dirt receptacles, empty according to manufacturer’s instructions after each test run, and clean the cloth filter bag or non-disposable dirt receptacle until its weight is within 0.07 oz (2 g) of its original weight (see 9.1.2).

9.3 *Set-Up for Sustained Air Performance and Exhaust Emissions Test:*

9.3.1 Set up the test equipment and test unit as shown in Fig. 2. Connect the suction fixture to the inlet side of the test unit and the emissions collection bag to the discharge side of the test unit. Ensure connections are secure and sealed. Do not attach a muffler to the exhaust line during this test.

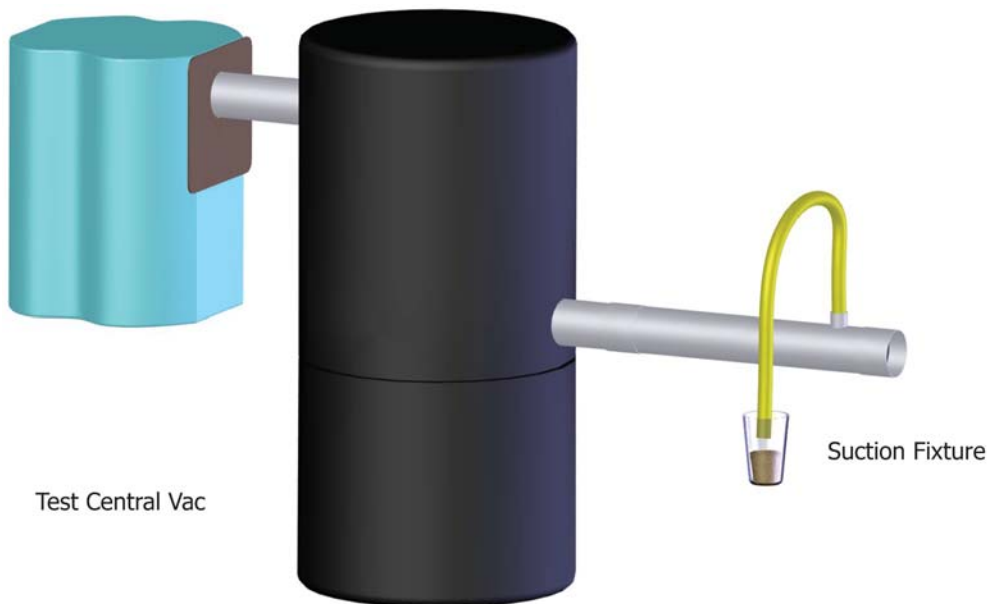

FIG. 2 Sustained Air Performance and Exhaust Emissions Setup