



Designation: G96 – 90 (Reapproved 2018)

Standard Guide for Online Monitoring of Corrosion in Plant Equipment (Electrical and Electrochemical Methods)¹

This standard is issued under the fixed designation G96; the number immediately following the designation indicates the year of original adoption or, in the case of revision, the year of last revision. A number in parentheses indicates the year of last reapproval. A superscript epsilon (ε) indicates an editorial change since the last revision or reapproval.

1. Scope

1.1 This guide covers the procedure for conducting online corrosion monitoring of metals in plant equipment under operating conditions by the use of electrical or electrochemical methods. Within the limitations described, these test methods can be used to determine cumulative metal loss or instantaneous corrosion rate, intermittently or on a continuous basis, without removal of the monitoring probes from the plant.

1.2 The following test methods are included: Test Method A for electrical resistance, and Test Method B for polarization resistance.

1.2.1 Test Method A provides information on cumulative metal loss, and corrosion rate is inferred. This test method responds to the remaining metal thickness except as described in Section 5.

1.2.2 Test Method B is based on electrochemical measurements for determination of instantaneous corrosion rate but may require calibration with other techniques to obtain true corrosion rates. Its primary value is the rapid detection of changes in the corrosion rate that may be indicative of undesirable changes in the process environment.

1.3 The values stated in SI units are to be considered standard. The values in parentheses are for information only.

1.4 *This standard does not purport to address all of the safety concerns, if any, associated with its use. It is the responsibility of the user of this standard to establish appropriate safety, health, and environmental practices and determine the applicability of regulatory limitations prior to use.* Specific precautionary statements are given in 5.6.

1.5 *This international standard was developed in accordance with internationally recognized principles on standardization established in the Decision on Principles for the Development of International Standards, Guides and Recommendations issued by the World Trade Organization Technical Barriers to Trade (TBT) Committee.*

¹ This guide is under the jurisdiction of ASTM Committee G01 on Corrosion of Metals and is the direct responsibility of ASTM Subcommittee G01.11 on Electrochemical Measurements in Corrosion Testing.

Current edition approved May 1, 2018. Published June 2018. Originally approved in 1990. Last previous edition approved in 2013 as G96 – 90 (2013). DOI: 10.1520/G0096-90R18.

2. Referenced Documents

2.1 *ASTM Standards*:²

D1125 Test Methods for Electrical Conductivity and Resistivity of Water

G1 Practice for Preparing, Cleaning, and Evaluating Corrosion Test Specimens

G3 Practice for Conventions Applicable to Electrochemical Measurements in Corrosion Testing

G4 Guide for Conducting Corrosion Tests in Field Applications

G15 Terminology Relating to Corrosion and Corrosion Testing (Withdrawn 2010)³

G59 Test Method for Conducting Potentiodynamic Polarization Resistance Measurements

G102 Practice for Calculation of Corrosion Rates and Related Information from Electrochemical Measurements

3. Terminology

3.1 *Definitions*—See Terminology G15 for definitions of terms used in this guide.

4. Summary of Guide

4.1 *Test Method A—Electrical Resistance*—The electrical resistance test method operates on the principle that the electrical resistance of a measuring element (wire, strip, or tube of metal) increases as its cross-sectional area decreases:

$$R = \sigma \frac{l}{A} \quad (1)$$

where:

R = resistance,

σ = resistivity of metal (temperature dependent),

l = length, and

A = cross-section area.

In practice, the resistance ratio between the measuring element exposed to corrosion and the resistance of a similar

² For referenced ASTM standards, visit the ASTM website, www.astm.org, or contact ASTM Customer Service at service@astm.org. For *Annual Book of ASTM Standards* volume information, refer to the standard's Document Summary page on the ASTM website.

³ The last approved version of this historical standard is referenced on www.astm.org.

reference element protected from corrosion is measured, to compensate for resistivity changes due to temperature. Based on the initial cross-sectional area of the measurement element, the cumulative metal loss at the time of reading is determined. Metal loss measurements are taken periodically and manually or automatically recorded against a time base. The slope of the curve of metal loss against time at any point is the correction rate at that point. The more frequently measurements are taken, the better is the resolution of the curve from which the corrosion rate is derived.

4.1.1 The electrical resistance of the metal elements being measured is very low (typically 2 to 10 mΩ). Consequently, special measurement techniques and cables are required to minimize the effect of cable resistance and electrical noise.

4.1.2 Various probe element cross-sectional areas are necessary so that a wide range of corrosion rates can be monitored with acceptable resolution.

4.2 Test Method B—Polarization Resistance:

4.2.1 The polarization resistance test method involves interaction with the electrochemical corrosion mechanism of metals in electrolytes in order to measure the instantaneous corrosion rate. Its particular advantage is its speed of response to corrosion rate upsets. On a corroding electrode subject to certain qualifications (see 12.1), it has been shown that the current density associated with a small polarization of the electrode is directly proportional to the corrosion rate of the electrode.

4.2.2 The polarization resistance equation is derived in Test Method G59. See Practice G3 for applicable conventions. For small polarization of the electrode (typically ΔE up to 20 mV), the corrosion current density is defined as:

$$i_{corr} = \frac{B}{R_p} \quad (2)$$

where:

- B = a combination of the anodic and cathodic Tafel slopes (b_a , b_c), and
- R_p = the polarization resistance with dimensions ohm-cm².

$$B = \frac{b_a b_c}{2.303 (b_a + b_c)} \quad (3)$$

4.2.3 The corrosion current density, i_{corr} , can be converted to corrosion rate of the electrode by Faraday’s law if the equivalent weight (EW) and density, ρ, of the corroding metal are known (see Practice G102):

$$\text{corrosion rate} = K_1 \frac{i_{corr}}{\rho} EW \quad (4)$$

where:

K_1 = a constant.

4.2.4 Equivalent weight of an element is the molecular weight divided by the valency of the reaction (that is, the number of electrons involved in the electrochemical reaction).

4.2.5 In order to obtain an alloy equivalent weight that is in proportion with the mass fraction of the elements present and their valence, it must be assumed that the oxidation process is uniform and does not occur selectively; that is, each element of the alloy corrodes as it would if it were the only element present. In some situations these assumptions are not valid.

4.2.6 Effective equivalent weight of an alloy is as follows:

$$\frac{1}{\sum_i^m \frac{n_i f_i}{W_i}} \quad (5)$$

where:

- f_i = mass fraction of i_{th} element in the alloy,
- W_i = atomic weight of the i_{th} element in the alloy,
- n_i = exhibited valence of the i_{th} element under the conditions of the corrosion process, and
- m = number of component elements in the alloy (normally only elements above 1 mass % in the alloy are considered).

Alloy equivalent weights have been calculated for many engineering metals and alloys and are tabulated in Practice G102.

4.2.7 Fig. 1 represents an equivalent circuit of polarization resistance probe electrodes in a corroding environment. The value of the double layer capacitance, C_{dl} , determines the charging time before the current density reaches a constant value, i , when a small potential is applied between the test and auxiliary electrode. In practice, this can vary from a few

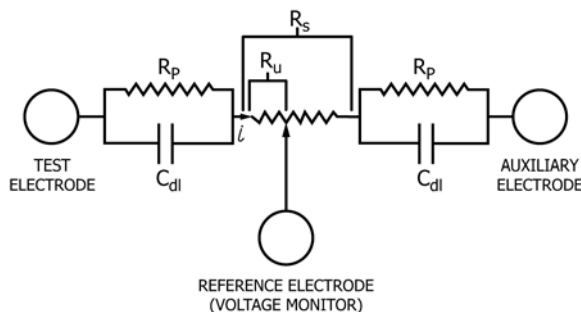

NOTE 1— R_s = Solution Resistance (ohm-cm⁻²) between test and auxiliary electrodes (increases with electrode spacing and solution resistivity).
 R_u = Uncompensated component of solution resistance (between test and reference electrodes) (ohm-cm⁻²).
 R_p = Polarization Resistance R_p (ohm-cm²).
 C_{dl} = Double layer capacitance of liquid/metal interface.
 i = Corrosion current density.

FIG. 1 Equivalent Circuit of Polarization Resistance Probe

seconds up to hours. When determining the polarization resistance, R_p , correction or compensation for solution resistance, R_s , is important when R_s becomes significant compared to R_p . Test Methods D1125 describes test methods for electrical conductivity and resistivity of water.

4.2.8 Two-electrode probes, and three-electrode probes with the reference electrode equidistant from the test and auxiliary electrode, do not correct for effects of solution resistance, without special electronic solution resistance compensation. With high to moderate conductivity environments, this effect of solution resistance is not normally significant (see Fig. 2).

4.2.9 Three-electrode probes compensate for the solution resistance, R_s , by varying degrees depending on the position and proximity of the reference electrode to the test electrode. With a close-spaced reference electrode, the effects of R_s can be

reduced up to approximately ten fold. This extends the operating range over which adequate determination of the polarization resistance can be made (see Fig. 2).

4.2.10 A two-electrode probe with electrochemical impedance measurement technique at high frequency short circuits the double layer capacitance, C_{dl} , so that a measurement of solution resistance, R_s , can be made for application as a correction. This also extends the operating range over which adequate determination of polarization resistance can be made (see Fig. 2).

4.2.11 Even with solution resistance compensation, there is a practical limit to the correction (see Fig. 2). At higher solution resistivities the polarization resistance technique cannot be used, but the electrical resistance technique may be used.

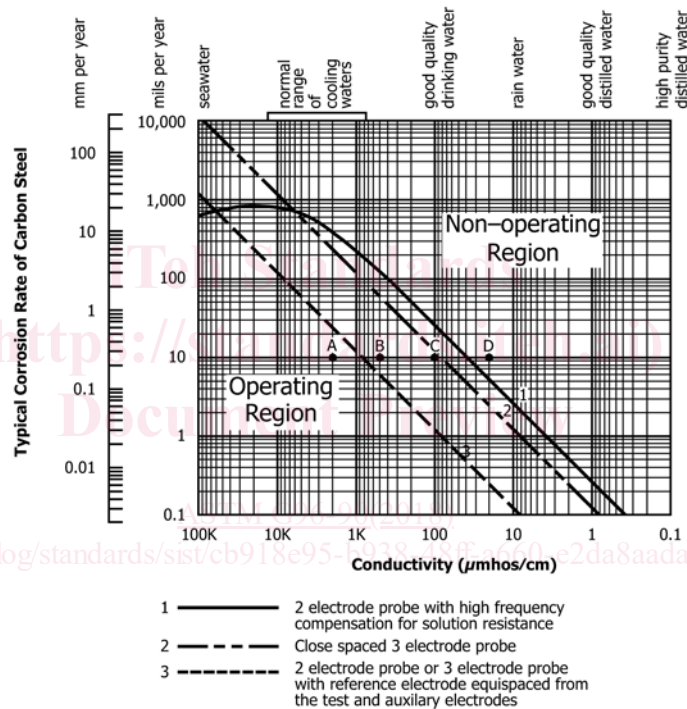

NOTE 1—See Appendix X1 for derivation of curves and Table X1.1 for description of points A, B, C and D.

NOTE 2—Operating limits are based on 20 % error in measurement of polarization resistance equivalent circuit (see Fig. 1).

NOTE 3—In the Stern-Geary equations, an empirical value of $B = 27.5$ mV has been used on the ordinate axis of the graph for “typical corrosion rate of carbon steel”.

NOTE 4—Conductivity $\frac{(\mu\text{mhos})}{\text{cm}} = \frac{1\,000\,000}{\text{Resistivity (ohm}\cdot\text{cm)}}$

NOTE 5—Effects of solution resistance are based on a probe geometry with cylindrical test and auxiliary electrodes of 4.75 mm (0.187 in.) diameter, 31.7 mm (1.25 ft) long with their axes spaced 9.53 mm (0.375 in.) apart. Empirical data shows that solution resistance (ohms-cm²) for this geometry = 0.55 × resistivity (ohms-cm²).

NOTE 6—A two-electrode probe, or three-electrode probe with the reference electrode equidistant from the test and auxiliary electrode, includes % of solution resistance between working and auxiliary electrodes in its measurement of R_p .

NOTE 7—A close-space reference electrode on a three electrode probe is assumed to be one that measures 5 % of solution resistance.

NOTE 8—In the method for Curve 1, basic polarization resistance measurement determines $2R_p + R_s$ (see Fig. 1). High frequency measurement short circuits C_{dl} to measure R_s . By subtraction polarization resistance, R_p is determined. The curve is based on high frequency measurement at 834 Hz with C_{dl} of 40 μF/cm² on above electrodes and ± 1.5 % accuracy of each of the two measurements.

NOTE 9—Curve 1 is limited at high conductivity to approximately 700 mpy by error due to impedance of C_{dl} at frequency 834 Hz. At low conductivity it is limited by the error in subtraction of two measurements where difference is small and the measurements large.

NOTE 10—Errors increase rapidly beyond the 20 % error line (see Appendix X1, Table X1.1).

FIG. 2 Guidelines on Operating Range for Polarization Resistance

4.2.12 Other methods of compensating for the effects of solution resistance, such as current interruption, electrochemical impedance and positive feedback have so far generally been confined to controlled laboratory tests.

5. Significance and Use

5.1 General corrosion is characterized by areas of greater or lesser attack, throughout the plant, at a particular location, or even on a particular probe. Therefore, the estimation of corrosion rate as with mass loss coupons involves an averaging across the surface of the probe. Allowance must be made for the fact that areas of greater or lesser penetration usually exist on the surface. Visual inspection of the probe element, coupon, or electrode is required to determine the degree of interference in the measurement caused by such variability. This variability is less critical where relative changes in corrosion rate are to be detected.

5.2 Both electrical test methods described in this guide provide a technique for determining corrosion rates without the need to physically enter the system to withdraw coupons as required by the methods described in Guide G4.

5.3 Test Method B has the additional advantage of providing corrosion rate measurement within minutes.

5.4 These techniques are useful in systems where process upsets or other problems can create corrosive conditions. An early warning of corrosive attack can permit remedial action before significant damage occurs to process equipment.

5.5 These techniques are also useful where inhibitor additions are used to control the corrosion of equipment. The indication of an increasing corrosion rate can be used to signal the need for additional inhibitor.

5.6 Control of corrosion in process equipment requires a knowledge of the rate of attack on an ongoing basis. These test methods can be used to provide such information in digital format easily transferred to computers for analysis.

TEST METHOD A—ELECTRICAL RESISTANCE (1-6)⁴

6. Limitations and Interferences

6.1 Results are representative for average metal loss on the probe element. On wire-form measuring elements, pitting may be indicated by rapid increases in metal loss reading after 50 % of probe life is passed. The larger cylindrical measuring elements are much less sensitive to the effect of pitting attack. Where pitting is the only form of attack, probes may yield unreliable results.

6.2 It should be recognized that the thermal noise and stress-induced noise on probe elements, and electrical noise on these systems, occur in varying degrees due to the process and local environment. Care should be exercised in the choice of the system to minimize these effects. Electrical noise can be minimized by use of correct cabling, and careful location of

equipment and cable runs (where applicable) to avoid electrically noisy sources such as power cables, heavy duty motors, switchgear, and radio transmitters.

6.2.1 The electrical resistivity of metals increases with increased temperature. Although basic temperature compensation is obtained by measuring the resistance ratio of an exposed test element and protected reference element, the exposed element will respond more rapidly to a change in temperature than does the protected reference element. This is a form of thermal noise. Various probes have different sensitivities to such thermal noise. Where temperature fluctuations may be significant, preference should be given to probes with the lowest thermal noise sensitivity.

6.2.2 If probe elements are flexed due to excessive flow conditions, a strain gage effect can be produced introducing stress noise onto the probe measurement. Suitable probe element shielding can remove such effects.

6.3 Process fluids, except liquid metals and certain molten salts, do not normally have sufficient electrical conductivity to produce a significant shorting effect on the electrical resistance of the exposed probe element. Conductive deposits (such as iron sulfide) can cause some short-circuiting effect on the element, reducing the measured metal loss, or showing some apparent metal gain. Certain probe configurations are less sensitive to this than others, depending on the path length between one end of the exposed probe element and the other.

6.4 When first introduced into a system, initial transient corrosion rates on a probe element may be different from the longer term corrosion rates.

6.4.1 Establishment of a probe element surface typical of the plant by passivation, oxidation, deposits, or inhibitor film build up may vary from hours to several days.

6.5 Since the corrosion rate is usually temperature dependent, results will be comparable only for the alloy at the process temperature to which the probes are exposed. In heat transfer environments actual plant metal temperatures may be significantly different from that of the test probe.

6.6 Electrical resistance probe elements are by their nature consumable. Hazardous situations may occur if probes are left in service for extended periods beyond their probe life. Crevice corrosion can cause damage or leaks at the element in some specimen configurations, that can cause false readings and early failure of probe elements. Normally the probe life is limited to approximately 50 % of the probe element thickness for safety reasons. Additionally, beyond this point measurements become increasingly erratic due to the irregular corroded surface of the probe element, and the particularly non-linear characteristics of wire probe elements.

6.6.1 Electrical resistance probes should be selected to provide a suitable backup seal, that is compatible with the process environment, in order to contain the process if the element seal fails.

7. Apparatus

7.1 *Electrical Resistance Corrosion Probes:*

7.1.1 A probe is composed of two elements of identical material. One is a measuring element and the other is a

⁴ The boldface numbers in parentheses refer to a list of references at the end of this standard.

protected reference element. In addition, a further check element is fully incorporated beyond the reference element to assist in monitoring of any process leakage into the probe.

7.1.2 Process monitoring probes are available in both retractable and non-retractable configurations. The former enables removal of the probe for inspection or probe replacement under operating conditions, except where operational safety precludes this.

7.1.3 There is a trade off between probe sensitivity and probe life. Care should be taken in selecting a probe sufficiently sensitive for the corrosion conditions, particularly when monitoring for process upsets.

7.1.4 Systems typically have a resolution of 0.1 % of probe life. However, for reasons of noise given in 6.2, it is generally recommended that only changes of greater than 1 % of probe life are used for calculation of a corrosion rate or detection of an upset. When monitoring steady metal loss rather than process upsets, probe life is generally more critical than response time. For example, a typical probe span suitable for a six month probe life would have on average a 1 % change approximately every two days.

7.1.5 For process upset detection, response time to the upset is much more critical than probe life. A probe sensitivity should be chosen such that 1 % of the probe life, at the upset corrosion rate, corresponds to the desired or maximum permissible response time to the upset condition. This generally will demand a more sensitive probe. However, since the upset condition will generally not exist for an extended period, the probe life will not be severely reduced.

7.1.6 Check compatibility of process fluid with probe materials and seals.

7.2 *Electrical Resistance Probe Monitoring Instruments:*

7.2.1 Portable, intermittent instruments, and continuous single and multi-channel instruments are available. Since the electrical resistance probe measures cumulative metal loss, the intermittent measurement permits the determination of the average corrosion rate only between the measurement points. With continuous monitoring, corrosion in real time can be determined.

7.2.2 Automatic continuous monitoring systems may be standalone systems or interfaced to other process computers, or both.

8. Probe Preparation

8.1 Commercial probes are generally received in sealed plastic bags to protect prepared surfaces. Care should be taken during installation to avoid handling the probe measurement element, that can cause additional corrosion.

8.2 Probe measurement element surfaces should be smooth and free of indentations or signs of mechanical damage. Grit-blasting with 120 grit is suitable as a surface preparation prior to degreasing.

8.3 If probes are being moved from one system to another, they must be cleaned mechanically before reuse to ensure complete removal of oxide or inhibitor films. Degreasing is necessary to complete the cleaning procedure. Practice G1

provides guidance on proper methods of cleaning various materials. Some people do not recommend reusing the probes.

8.4 Mechanical or chemical cleaning will remove metal from the probe measurement element, increasing its reading. This new reading should be taken immediately after installation in the new location.

9. Probe Installation

9.1 Install the probe in a position as representative of the corrosive environment as possible without causing deleterious effects to the probe or the system. Do not mount probe transversely in a high-flow pipeline without shielding (see 6.3).

9.2 Do not install the probe in a dead-end section where temperature or flow conditions, or both, are not representative of the system under examination.

10. Procedure

10.1 *Portable Intermittent Instrument:*

10.1.1 Check correct operation of the instrument with the test probe provided according to the manufacturer's instructions.

10.1.2 Connect the instrument to the probe and log both the measure and check readings. Ensure that the check reading is within specified limits. Follow the manufacturer's instructions to convert the measured reading to cumulative metal loss. Check that the readings are steady and record the midpoint and extent of any variation of the reading.

10.2 *Automatic Continuous Monitoring Instruments:*

10.2.1 These instruments are available in various single or multi-channel configurations. They may be standalone systems or interfaced with process computers, or both. These units provide continuous information on metal loss or corrosion rates, or both.

10.2.2 The system should be installed and tested according to the manufacturer's instructions. Test probes are normally provided to assist the set-up of all channels and cabling of the system.

10.2.3 Connect the operational probes into the system.

10.2.4 Various output forms of information are available, together with alarms. Computerized systems will often allow alarms to be set for excessive corrosion rates to draw attention to problem areas that may then be analyzed in detail from the metal loss versus time graph. Generally the most useful form of data is the graph of metal loss versus time for each monitored point.

11. Interpretation of Results

11.1 Plot the graph of metal loss versus time. Upsets and changes in corrosion rate will be readily observable as changes in the slope of the curve. The average corrosion rate will be the slope of the line connecting the two points on the curve over the time period under consideration. The maximum corrosion rate will be the slope of the tangent to the curve at the steepest point of the curve (see Fig. 3).

11.2 Some systems automatically calculate corrosion rates over various periods.

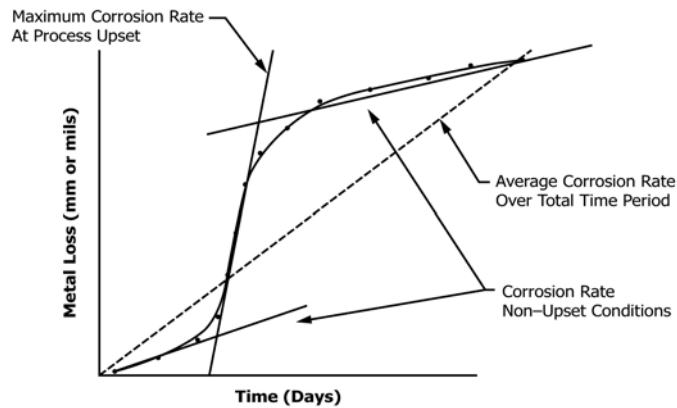

FIG. 3 Typical Plot of Metal Loss Versus Time

11.3 Careful interpretation is necessary in correlating these corrosion test results with actual metal corrosion in the plant. Comparison with metal coupon results (see Guide G4) or with actual metal exposed in the plant is recommended.

11.3.1 Actual mass loss incurred by the probe elements can be used to establish correlations between the corrosion rate estimated by the electrical resistance methods and actual corrosion losses. Practice G1 provides guidance on methods of evaluating mass loss.

**TEST METHOD B—POLARIZATION RESISTANCE
(2, 3, 4, and 6-25)**

12. Limitations and Interferences

12.1 In the case of polarization resistance measurements, interferences derive from both theoretical and practical assumptions and limitations.

12.1.1 The theoretical polarization resistance equations in 4.2.2 on which the measurement is based are derived on the following assumptions: (2, 19)

12.1.1.1 The corrosion is uniform.

12.1.1.2 The corrosion mechanism consists of only one anodic and one cathodic reaction. The corrosion potential is not near the redox potential of either reaction.

12.1.1.3 Other secondary reactions that are not directly corrosion related but involve charge transfer are not significant.

12.1.1.4 Metals or alloys should give Tafel kinetics for both anodic and cathodic reactions.

12.1.1.5 Measurements are made over a sufficiently small polarization range that the potential-current plot is essentially linear.

12.2 The polarization resistance technique is restricted to use in sufficiently conductive environments (refer to Fig. 2).

12.3 Deposits on the electrodes may affect the results.

12.4 When polarization of an electrode is made by the polarization resistance measurement, time is required to charge the double layer capacitance, C_{dl} , (see Fig. 1) before a measurement can be taken. The assumption is that the corrosion potential has remained constant through this measurement cycle. This assumption can be a limitation if long cycle times are used, particularly in a dynamic plant environment.

12.5 The theoretical polarization resistance equation in 4.2.2 relates only to the corrosion interface. In practical measurements solution resistance becomes an increasing interference in low conductivity environments.

12.5.1 A general indication of limits of use are shown in Fig. 2. (For derivation of curves in Fig. 2 and examples of errors, see Appendix X1.) The main limitations of each technique in plant equipment are as follows:

12.5.1.1 *Two-Electrode Probes and Three Electrode Probes With Equidistant Reference Electrode*—Limited as solution resistance becomes significant compared with polarization resistance.

12.5.1.2 *Three-Electrode Probe With Close-Space Reference Electrode*—Compensation for solution resistance limited by physical proximity of reference electrode to test electrode and its position in the potential field between the test and auxiliary electrode.

12.5.1.3 *High Frequency Measurement for Compensation of Solution Resistance*—Limited by error of small differences between two large numbers at high solution resistance, and the frequency of the resistance compensation measurement.

12.5.1.4 *Current Interruption for Compensation of Solution Resistance*—Limited by noise on high impedance input at time of current interruption measurement.

12.6 In actual plant measurements, fouling or bridging of electrodes with conductive deposits may reduce the apparent value of polarization resistance thereby indicating a higher corrosion rate. This will invalidate measurements until the probe is cleaned.

12.7 Probes of pitted metal or metal with sharp edges may yield unreliable results. General reuse of probe electrodes is not recommended.

12.8 Since the corrosion rate is usually temperature dependent, results will be comparable only for the alloy at the process temperature to which the probes are exposed. In heat transfer environments actual plant metal temperatures may be significantly different from that of the test probe.

12.9 The corrosion rates occurring on the probe electrodes during the first few hours or days of exposure may not be typical of corrosion occurring in the system. Establishment of