



# Standard Specification for Helmets Used in Recreational Bicycling or Roller Skating<sup>1</sup>

This standard is issued under the fixed designation F1447; the number immediately following the designation indicates the year of original adoption or, in the case of revision, the year of last revision. A number in parentheses indicates the year of last reappraisal. A superscript epsilon ( $\epsilon$ ) indicates an editorial change since the last revision or reappraisal.

## 1. Scope

1.1 This specification covers performance requirements for helmets manufactured for use by recreational bicyclists or roller skaters. This specification recognizes the desirability of lightweight construction and ventilation; however, it is a performance standard and is not intended to restrict design.

1.2 All testing and requirements of this specification shall be in accordance with Test Methods F1446, except where noted herein.

1.3 Partial utilization of this specification is prohibited. Any statement of compliance with this specification shall be a certification that the product meets all of the requirements of the specification in its entirety. A product that fails to meet any one of the requirements of this specification is considered to have failed the standard and should not be sold with any indication that it meets parts of the standard.

1.4 This standard is subject to revision at any time by ASTM. It must be reviewed every five years and if not revised either reapproved or withdrawn. References to the standard must include the version date. No references to a version that has been replaced or withdrawn shall be placed on any product or its packaging manufactured more than 24 months after the effective revision or withdrawal date. Go to [astm.org](http://astm.org) to verify the latest version of this standard.

NOTE 1—The current edition of this standard was approved on June 1, 2018.

1.5 *This international standard was developed in accordance with internationally recognized principles on standardization established in the Decision on Principles for the Development of International Standards, Guides and Recommendations issued by the World Trade Organization Technical Barriers to Trade (TBT) Committee.*

## 2. Referenced Documents

2.1 *ASTM Standards:*<sup>2</sup>

F1446 Test Methods for Equipment and Procedures Used in Evaluating the Performance Characteristics of Protective Headgear

F2043 Classification for Bicycle Usage

## 3. Terminology

3.1 *Definitions of Terms Specific to This Standard:*

3.1.1 *recreational bicycling, n*—bicycling in conditions up to Condition 3 as specified in Classification F2043.

3.1.2 *in-lines, n*—roller skates with all wheels on each skate arranged along a single longitudinal line.

3.1.3 *quads, n*—roller skates with four wheels on each skate arranged in a rectangular pattern.

3.1.4 *recreational roller skating, n*—skating horizontally using quads or in-lines but not roller hockey or trick roller skating such as ramp jumping, sliding sideways, or skating on stairs.

## 4. Headforms

4.1 Headforms to be used in this specification are as specified in the section on Test Headforms of Test Methods F1446, using the variable mass drop assembly configuration. The appropriate size headform shall be selected in accordance with the section on Headform Size of Test Methods F1446 for the helmet to be tested.

<sup>1</sup> This specification is under the jurisdiction of ASTM Committee F08 on Sports Equipment, Playing Surfaces, and Facilities and is the direct responsibility of Subcommittee F08.53 on Headgear and Helmets.

Current edition approved July 1, 2012; June 1, 2018. Published August 2012; June 2018. Originally approved in 1993. Last previous edition approved in 2006 as F1447 – 06; F1447 – 12. DOI: 10.1520/F1447-12; 10.1520/F1447-18.

<sup>2</sup> For referenced ASTM standards, visit the ASTM website, [www.astm.org](http://www.astm.org), or contact ASTM Customer Service at [service@astm.org](mailto:service@astm.org). For Annual Book of ASTM Standards volume information, refer to the standard's Document Summary page on the ASTM website.

4.2 In addition to the provisions of Test Methods F1446, the center of gravity of the headform must be within a 10° vertical cone from the center of impact and lie within a rectangular area 28 by 12.8 mm oriented as shown in Fig. 1. The center of gravity of the drop assembly shall lie within 6.4 mm millimeters of the Z-X plane, which is defined for twin wire systems as the plane containing the axes of the two guide wires, and for monorail systems as the plane containing the design center of the headform and the axis of the monorail. The center of gravity of the drop assembly shall lie within 6.4 mm of the Y-Z plane on the side opposite the arm of the ball arm and within 21.6 mm of the Y-Z plane on the side containing the ball arm where the Y-Z plane is perpendicular to the Z-X plane and contains the design center of the headform. Please see Fig. 1. The center of the anvil must be fixed in alignment with the center vertical axis of the accelerometer.

**5. Anvils and Impact Velocities**

5.1 Anvils to be used for impact tests in this specification are the flat, hemispherical, and curbstone anvils described in the section on Apparatus of Test Methods F1446.

5.2 The helmet shall be dropped onto the flat anvil to achieve an impact velocity of 6.2 m/s (corresponding to a theoretical drop height of 2.0 m).

5.3 The helmet shall be dropped onto the hemispherical and curbstone anvils to achieve an impact velocity of 4.8 m/s (corresponding to a theoretical drop height of 1.2 m).

5.4 The impact velocity shall be measured during the last 40 mm of free-fall for each test and shall be within ±3 % of the velocities specified in 5.2 and 5.3.

**6. Marking the Test Line (Area of Required Coverage)**

6.1 Place the helmet on the appropriate size headform in accordance with the section on Headform Size Selection of Test Methods F1446 and preload with a preload ballast weight of 5 kg.

6.2 Position the helmet as specified by the manufacturer’s head positioning index (HPI) with the brow parallel to the basic plane.

6.3 Draw a line A-B-C-D on the helmet as shown in Fig. 2. This represents the test line defined in Test Methods F1446.

**7. Conditioning, Number of Samples and Laboratory Environment**

7.1 The test normally requires eight samples of each shell/liner combination.

7.2 Conditioning of the samples to be tested is described in the section on Conditioning Environment of Test Methods F1446, except that the ambient sample may be conditioned in an environment at 17 to 27°C with a relative humidity of 20 to 80 %, and the wet sample is to be submerged inverted in potable water at a temperature of 17 to 27°C to an external crown depth of at least 305 ± 25 mm.

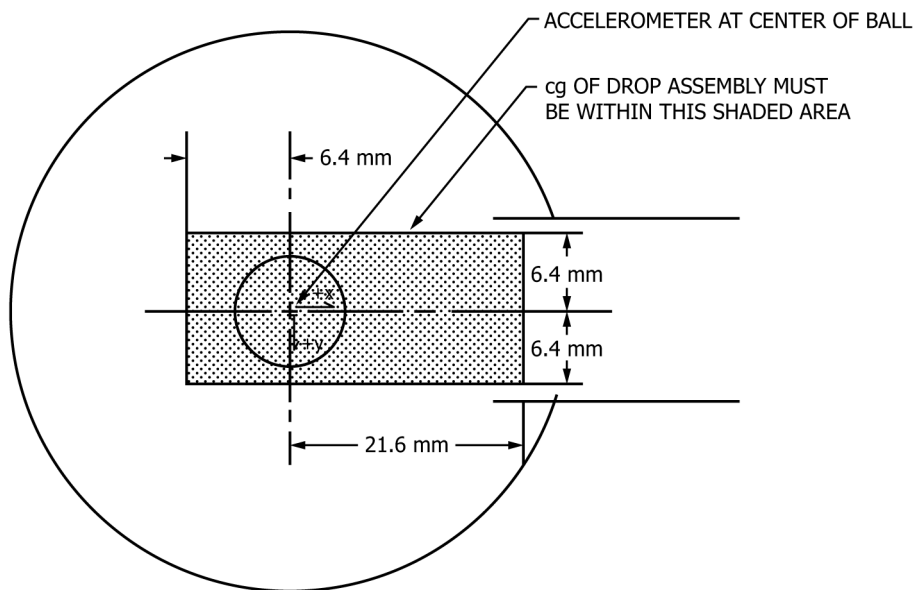

NOTE 1—Overview of ball-arm as installed on impact test apparatus.

NOTE 2—Coordinate system as defined in FMVSS 218, revised April 6, 1988. Z axis positive downward (into page).

**FIG. 1 Center of Gravity for Drop Assembly**