



Designation: C806 – 18

# Standard Test Method for Restrained Expansion of Expansive Cement Mortar<sup>1</sup>

This standard is issued under the fixed designation C806; the number immediately following the designation indicates the year of original adoption or, in the case of revision, the year of last revision. A number in parentheses indicates the year of last reapproval. A superscript epsilon ( $\epsilon$ ) indicates an editorial change since the last revision or reapproval.

## 1. Scope

1.1 This test method covers the determination of length changes of expansive cement mortar, while under restraint, due to the development of internal forces resulting from hydration of the cement.

1.2 The values stated in inch-pound units are to be regarded as standard. The values given in parentheses are mathematical conversions to SI units that are provided for information only and are not considered standard.

1.3 The text of this standard references notes and footnotes which provide explanatory material. These notes and footnotes (excluding those in tables and figures) shall not be considered as requirements of this standard.

1.4 *This standard does not purport to address all of the safety concerns, if any, associated with its use. It is the responsibility of the user of this standard to establish appropriate safety, health, and environmental practices and determine the applicability of regulatory limitations prior to use. (Warning—Fresh hydraulic cement mixtures are caustic and may cause burns to skin and tissue upon prolonged exposure.<sup>2</sup>)*

1.5 *This international standard was developed in accordance with internationally recognized principles on standardization established in the Decision on Principles for the Development of International Standards, Guides and Recommendations issued by the World Trade Organization Technical Barriers to Trade (TBT) Committee.*

## 2. Referenced Documents

### 2.1 ASTM Standards:<sup>3</sup>

- A307 Specification for Carbon Steel Bolts, Studs, and Threaded Rod 60 000 PSI Tensile Strength
- C109/C109M Test Method for Compressive Strength of

Hydraulic Cement Mortars (Using 2-in. or [50-mm] Cube Specimens)

- C157/C157M Test Method for Length Change of Hardened Hydraulic-Cement Mortar and Concrete
- C219 Terminology Relating to Hydraulic Cement
- C305 Practice for Mechanical Mixing of Hydraulic Cement Pastes and Mortars of Plastic Consistency
- C490/C490M Practice for Use of Apparatus for the Determination of Length Change of Hardened Cement Paste, Mortar, and Concrete
- C670 Practice for Preparing Precision and Bias Statements for Test Methods for Construction Materials
- C778 Specification for Standard Sand
- C1005 Specification for Reference Masses and Devices for Determining Mass and Volume for Use in the Physical Testing of Hydraulic Cements
- F606/F606M Test Methods for Determining the Mechanical Properties of Externally and Internally Threaded Fasteners, Washers, Direct Tension Indicators, and Rivets

## 3. Terminology

3.1 Definitions of terms used in this test method are given in Terminology C219.

## 4. Apparatus

4.1 *Molds*—The molds for casting test specimens, when used in conjunction with the restraining cage described in 4.2, shall provide for forming either 2 by 2 by 10-in. prisms having a 10-in. gage length, or 50 by 50 by 250-mm prisms having a 250-mm gage length. The molds shall otherwise conform to the requirements of Practice C490/C490M, except that the gage stud holder, gage studs, and spacer screws described in that specification will not be used.

4.2 *Restraining Cage*, consisting of a threaded steel rod with steel end plates held in place by nuts as shown in Fig. 1. The rod shall be provided with cap nuts for prevention of corrosion. The rod shall conform to Specification A307 Grade A except, it shall support 1180-lbf (5249 N) proof load when tested in accordance with Method 1 of Test Methods F606/F606M.

4.3 *Length Comparator*—The length comparator for measuring length shall conform to and be used in accordance with the requirements of Practice C490/C490M. If the terminals of

<sup>1</sup> This test method is under the jurisdiction of ASTM Committee C01 on Cement and is the direct responsibility of Subcommittee C01.13 on Special Cements.

Current edition approved July 1, 2018. Published July 2018. Originally approved in 1975. Last previous edition approved in 2012 as C806 – 12. DOI: 10.1520/C0806-18.

<sup>2</sup> Section of Safety, Manual of Cement Testing, *Annual Book of ASTM Standards*, Vol 04.01.

<sup>3</sup> For referenced ASTM standards, visit the ASTM website, www.astm.org, or contact ASTM Customer Service at service@astm.org. For *Annual Book of ASTM Standards* volume information, refer to the standard's Document Summary page on the ASTM website.

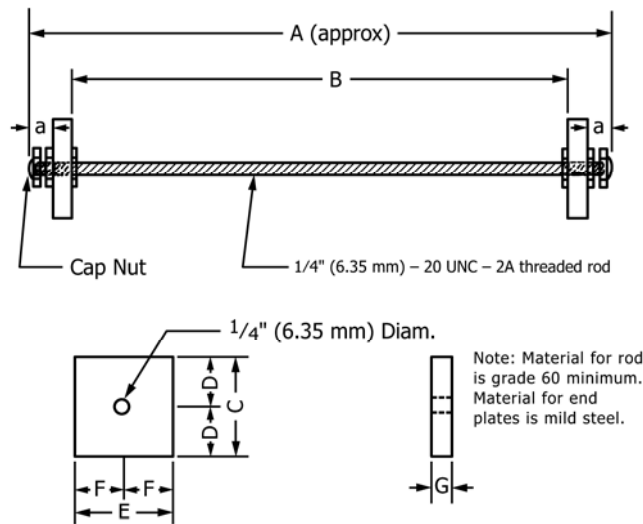

	Dimension, in. (mm)	Tolerance, in. (mm)
A	11 <sup>3</sup> / <sub>4</sub> (300)	...
B	10 (250)	1/8 (3)
C	2 (50)	...
D	1 (25)	...
E	1 <sup>3</sup> / <sub>32</sub> (49)	1/32 (1)
F	6 <sup>3</sup> / <sub>64</sub> (24.5)	...
G	3/8 (10)	...

FIG. 1 Restraining Cage

the comparator are fitted with collars, they shall be such that the cap nuts on the ends of the threaded rod of the specimen do not rest on the collar during measuring.

4.4 *Tamper*—The tamper shall be made of nonabsorptive, nonabrasive material such as medium-hard rubber or seasoned oak wood, rendered nonabsorptive by immersion for 15 min in paraffin at approximately 392°F (200°C), and shall have a cross section of about 1/2 by 1 in. (13 by 25 mm) and convenient length of about 6 in. (150 mm). The tamping face of the tamper shall be flat and at right angles to the length of the tamper.

4.5 *Apparatus for Demolding Specimens*—Apparatus similar to that described in the Apparatus section of Test Method C157/C157M, may be found useful for demolding specimens.

4.6 *Weights and Weighing Devices*—Scales used shall comply with Specification C1005.

4.7 *Glass Graduate* that conforms to the requirements of Test Method C109/C109M.

4.8 *Mixer, Bowl, and Paddle*—The mixer shall be an electrically driven mechanical mixer of the type equipped with paddle and mixing bowl, as specified in the Apparatus section of Practice C305.

4.9 *Trowel*—The trowel shall have a steel blade 4 to 6 in. (102 to 152 mm) in length, with straight edges.

## 5. Temperature and Humidity

5.1 The temperature of the air in the vicinity of the mixing operation, the dry materials, mixing water, molds, base plates,

mixing bowl, moist closet or moist room, and storage water shall not vary from 73.4°F (23°C) by more than ±3°F (±1.7°C).

5.2 The relative humidity of the laboratory shall be not less than 50%. The moist closet or moist room shall provide a relative humidity of not less than 95%.

## 6. Graded Standard Sand

6.1 Sand used shall comply with the graded sand requirement of Specification C778.

Passing Sieve	Percentage Retained
No. 100 (150-µm)	98 ± 2
No. 50 (300-µm)	72 ± 5
No. 30 (600-µm)	2 ± 2
No. 16 (1.18-mm)	none

NOTE 1—*Segregation of Graded Sand*—The graded standard sand should be handled in such a manner as to prevent segregation, since variations in the grading of the sand cause variations in the consistency of the mortar. In emptying sacks of sand into bins or in scooping sand out of bins or sacks, care should be exercised to prevent the formation of mounds of sand or craters in the sand, down the slopes of which the coarser particles will roll. Bins should be of sufficient size to permit these precautions. Devices for drawing the sand from bins by gravity should not be used.

## 7. Test Specimen

7.1 The test specimen shall be a 2 by 2 by 10-in. prism having a 10-in. gage length, or a 50 by 50 by 250-mm prism having a 250-mm gage length. At least two specimens shall be prepared for each test.