



Designation: **D5766/D5766M – 11** D5766/D5766M – 11 (Reapproved 2018)

Standard Test Method for Open-Hole Tensile Strength of Polymer Matrix Composite Laminates¹

This standard is issued under the fixed designation D5766/D5766M; the number immediately following the designation indicates the year of original adoption or, in the case of revision, the year of last revision. A number in parentheses indicates the year of last reapproval. A superscript epsilon (ϵ) indicates an editorial change since the last revision or reapproval.

1. Scope

1.1 This test method determines the open-hole tensile strength of multidirectional polymer matrix composite laminates reinforced by high-modulus fibers. The composite material forms are limited to continuous-fiber or discontinuous-fiber (tape or fabric, or both) reinforced composites in which the laminate is balanced and symmetric with respect to the test direction. The range of acceptable test laminates and thicknesses are described in 8.2.1.

1.2 The values stated in either SI units or inch-pound units are to be regarded separately as standard. The values stated in each system may not be exact equivalents; therefore, each system shall be used independently of the other. Combining values from the two systems may result in non-conformance with the standard.

1.2.1 Within the text the inch-pound units are shown in brackets.

1.3 *This standard does not purport to address all of the safety concerns, if any, associated with its use. It is the responsibility of the user of this standard to establish appropriate safety, health, and environmental practices and determine the applicability of regulatory limitations prior to use.*

1.4 *This international standard was developed in accordance with internationally recognized principles on standardization established in the Decision on Principles for the Development of International Standards, Guides and Recommendations issued by the World Trade Organization Technical Barriers to Trade (TBT) Committee.*

2. Referenced Documents

2.1 *ASTM Standards:*²

D792 Test Methods for Density and Specific Gravity (Relative Density) of Plastics by Displacement

D883 Terminology Relating to Plastics

D2584 Test Method for Ignition Loss of Cured Reinforced Resins

D2734 Test Methods for Void Content of Reinforced Plastics

D3039/D3039M Test Method for Tensile Properties of Polymer Matrix Composite Materials

D3171 Test Methods for Constituent Content of Composite Materials

D3878 Terminology for Composite Materials

D5229/D5229M Test Method for Moisture Absorption Properties and Equilibrium Conditioning of Polymer Matrix Composite Materials

E6 Terminology Relating to Methods of Mechanical Testing

E177 Practice for Use of the Terms Precision and Bias in ASTM Test Methods

E456 Terminology Relating to Quality and Statistics

E691 Practice for Conducting an Interlaboratory Study to Determine the Precision of a Test Method

E1309 Guide for Identification of Fiber-Reinforced Polymer-Matrix Composite Materials in Databases (Withdrawn 2015)³

E1434 Guide for Recording Mechanical Test Data of Fiber-Reinforced Composite Materials in Databases (Withdrawn 2015)³

3. Terminology

3.1 *Definitions*—Terminology D3878 defines terms relating to high-modulus fibers and their composites. Terminology D883 defines terms relating to plastics. Terminology E6 defines terms relating to mechanical testing. Terminology E456 and Practice

¹ This test method is under the jurisdiction of ASTM Committee D30 on Composite Materials and is the direct responsibility of Subcommittee D30.05 on Structural Test Methods.

Current edition approved Jan. 1, 2011; June 1, 2018. Published February 2011; July 2018. Originally approved in 1995. Last previous edition approved in 2007/2011 as D5766/D5766M – 07; D5766/D5766M – 11. DOI: 10.1520/D5766_D5766M-11-10.1520/D5766_D5766M-11R18.

² For referenced ASTM standards, visit the ASTM website, www.astm.org, or contact ASTM Customer Service at service@astm.org. For *Annual Book of ASTM Standards* volume information, refer to the standard's Document Summary page on the ASTM website.

³ The last approved version of this historical standard is referenced on www.astm.org.

E177 define terms relating to statistics. In the event of a conflict between terms, Terminology **D3878** shall have precedence over the other standards.

3.2 Definitions of Terms Specific to This Standard:

NOTE 1—If the term represents a physical quantity, its analytical dimensions are stated immediately following the term (or letter symbol) in fundamental dimension form, using the following ASTM standard symbology for fundamental dimensions, shown within square brackets: $[M]$ for mass, $[L]$ for length, $[T]$ for time, $[\theta]$ for thermodynamic temperature, and $[nd]$ for non-dimensional quantities. Use of these symbols is restricted to analytical dimensions when used with square brackets, as the symbols may have other definitions when used without the brackets.

3.2.1 *diameter-to-thickness ratio, D/h [nd], n —in an open-hole specimen, the ratio of the hole diameter to the specimen thickness.*

3.2.1.1 *Discussion*—The diameter-to-thickness ratio may be either a nominal value determined from nominal dimensions or an actual value determined from measured dimensions.

3.2.2 *nominal value, n —a value, existing in name only, assigned to a measurable property for the purpose of convenient designation. Tolerances may be applied to a nominal value to define an acceptable range for the property.*

3.2.3 *principal material coordinate system, n —a coordinate system with axes that are normal to the planes of symmetry inherent to a material.*

3.2.3.1 *Discussion*—Common usage, at least for Cartesian axes (123, xyz , and so forth), generally assigns the coordinate system axes to the normal directions of planes of symmetry in order that the highest property value in a normal direction (for elastic properties, the axis of greatest stiffness) would be 1 or x , and the lowest (if applicable) would be 3 or z . Anisotropic materials do not have a principal material coordinate system due to the total lack of symmetry, while, for isotropic materials, any coordinate system is a principal material coordinate system. In laminated composites, the principal material coordinate system has meaning only with respect to an individual orthotropic lamina. The related term for laminated composites is “reference coordinate system.”

3.2.4 *reference coordinate system, n —a coordinate system for laminated composites used to define ply orientations. One of the reference coordinate system axes (normally the Cartesian x -axis) is designated the reference axis, assigned a position, and the ply principal axis of each ply in the laminate is referenced relative to the reference axis to define the ply orientation for that ply.*

3.2.5 *specially orthotropic, adj*—a description of an orthotropic material as viewed in its principal material coordinate system. In laminated composites, a specially orthotropic laminate is a balanced and symmetric laminate of the $[0_i/90_j]_{ns}$ family as viewed from the reference coordinate system, such that the membrane-bending coupling terms of the laminate constitutive relation are zero.

3.2.6 *width-to-diameter ratio, w/D [nd], n —in an open-hole specimen, the ratio of the specimen width to the hole diameter.*

3.2.6.1 *Discussion*—The width-to-diameter ratio may be either a nominal value determined from nominal dimensions or an actual value determined from measured dimensions.

3.3 Symbols:

A = cross-sectional area of a specimen

CV = coefficient of variation statistic of a sample population for a given property (in percent)

D = hole diameter

h = specimen thickness

n = number of specimens per sample population

N = number of plies in laminate under test

F_x^{OHTu} = ultimate open-hole (notched) tensile strength in the test direction

P^{max} = maximum force carried by test specimen prior to failure

s_{n-1} = standard deviation statistic of a sample population for a given property

S_r = repeatability (within laboratory precision) standard deviation, calculated in accordance with Practice **E691**

S_R = reproducibility (between laboratory precision) standard deviation, calculated in accordance with Practice **E691**

w = specimen width

x_i = test result for an individual specimen from the sample population for a given property

\bar{x} = mean or average (estimate of mean) of a sample population for a given property

σ = normal stress

4. Summary of Test Method

4.1 A uniaxial tension test of a balanced, symmetric laminate is performed in accordance with Test Method **D3039/D3039M**, although with a centrally located hole. Edge-mounted extensometer displacement transducers are optional. Ultimate strength is calculated based on the gross cross-sectional area, disregarding the presence of the hole. While the hole causes a stress concentration and reduced net section, it is common aerospace practice to develop notched design allowable strengths based on gross section stress to account for various stress concentrations (fastener holes, free edges, flaws, damage, and so forth) not explicitly modeled in the stress analysis.

4.2 The only acceptable failure mode for ultimate open-hole tensile strength is one which passes through the hole in the test specimen.

5. Significance and Use

5.1 This test method is designed to produce notched tensile strength data for structural design allowables, material specifications, research and development, and quality assurance. Factors that influence the notched tensile strength and should therefore be reported include the following: material, methods of material fabrication, accuracy of lay-up, laminate stacking sequence and overall thickness, specimen geometry (including hole diameter, diameter-to-thickness ratio, and width-to-diameter ratio), specimen preparation (especially of the hole), specimen conditioning, environment of testing, specimen alignment and gripping, speed of testing, time at temperature, void content, and volume percent reinforcement. Properties that may be derived from this test method include the following:

5.1.1 Open-hole (notched) tensile strength (OHT).

6. Interferences

6.1 *Hole Preparation*—Due to the dominating presence of the notch, and the lack of need to measure the material response, results from this test method are relatively insensitive to parameters that would be of concern in an unnotched tensile property test. However, since the notch dominates the strength, consistent preparation of the hole, without damage to the laminate, is important to meaningful results. Damage due to hole preparation will affect strength results. Some types of damage, such as delaminations, can blunt the stress concentration due to the hole, increasing the force-carrying capacity of the specimen and the calculated strength. Other types of damage can reduce the calculated strength.

6.2 *Specimen Geometry*—Results are affected by the ratio of specimen width to hole diameter (w/D); this ratio should be maintained at 6, unless the experiment is investigating the influence of this ratio. Results may also be affected by the ratio of hole diameter to thickness (D/h); the preferred ratio is the range from 1.5 to 3.0 unless the experiment is investigating the influence of this ratio. Results may also be affected by specimen length⁴; the preferred specimen length is in the range from 200 to 300 mm [8.0 to 12.0 in.]. Shorter specimens (150 to 200 mm [6.0 to 8.0 in.]) may be utilized in accordance with the limitations defined in 8.2.2. The equivalence of test results from Configurations A and B is contingent upon several factors, including fiber strain-to-failure, resin strength and fracture toughness. Laminates with a propensity to develop sub-critical resin splits and cracks could potentially be affected by a change in specimen length due to closer grip proximity to the hole (and any longitudinal cracks that may develop).

6.3 *Material Orthotropy*—The degree of laminate orthotropy strongly affects the failure mode and measured OHT strength. Valid OHT strength results should only be reported when appropriate failure modes are observed, in accordance with 11.5.

6.4 *Thickness Scaling*—Thick composite structures do not necessarily fail at the same strengths as thin structures with the same laminate orientation (that is, strength does not always remain constant independent of specimen thickness). Thus, data gathered using this test method may not translate directly into equivalent thick-structure properties.

6.5 *Other*—Additional sources of potential data scatter in testing of composite materials are described in Test Method D3039/D3039M.

7. Apparatus

7.1 Apparatus shall be in accordance with Test Method D3039/D3039M. Additionally, a micrometer or gage capable of determining the hole diameter to ± 0.025 mm [± 0.001 in.] is required.

8. Sampling and Test Specimens

8.1 *Sampling*—Sampling shall be in accordance with Test Method D3039/D3039M.

8.2 *Geometry*—The specimen geometry shall be in accordance with Test Method D3039/D3039M, as modified by the following, and illustrated by the schematic of Fig. 1. Any variation of the stacking sequence, specimen width or length, or hole diameter from that specified shall be clearly noted in the report.

8.2.1 *Stacking Sequence*—The standard laminate shall have multidirectional fiber orientations (fibers shall be oriented in a minimum of two directions), and balanced and symmetric stacking sequences. Nominal thickness shall be 2.5 mm [0.10 in.], with a permissible range of 2 to 4 mm [0.080 to 0.160 in.], inclusive. Fabric laminates containing satin-type weaves shall have symmetric warp surfaces, unless otherwise noted in the report.

NOTE 2—Typically a $[45/-45/0/90]_{ms}$ tape or $[45/0]_{ms}$ fabric laminate should be selected such that a minimum of 5 % of the fibers lay in each of the four principal orientations. This laminate design has been found to yield the highest likelihood of acceptable failure modes.

8.2.2 *Configuration:*

8.2.2.1 *Configuration A*—The width of the specimen is 36 ± 1 mm [1.50 ± 0.05 in.] and the length range is 200 to 300 mm [8.0 to 12.0 in.]. The notch consists of a centrally located hole, 6 ± 0.06 mm [0.250 ± 0.003 in.] in diameter, centered by length

⁴ Chris, R. M., "Comparison of Quasi-Isotropic Laminate Open-Hole Tension Strength vs. Specimen Length by Experimental Evaluation," Bell Helicopter Textron Report BL2010-240, July 2010.

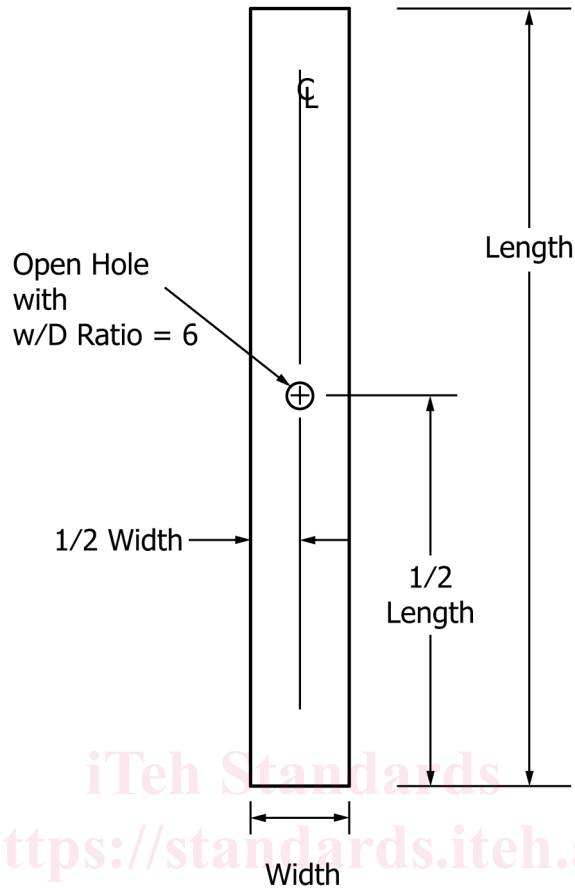

FIG. 1 Schematic of Open-Hole Tension Test Specimen

to within 0.12 mm [0.005 in.] and by width to within 0.05 mm [0.002 in.]. While tabs may be used, they are not required and generally not needed, since the open hole acts as sufficient stress riser to force failure in the notched region. Configuration A is preferred for the general laminate stacking sequences defined in 8.2.1 because it is long enough to ensure a uniform strain field is achieved in the specimen outside of the influence of the hole.

8.2.2.2 *Configuration B*—The width of the specimen is 36 ± 1 mm [1.50 ± 0.05 in.] and the length range is 150 to 200 mm [6.0 to 8.0 in.]. The notch consists of a centrally located hole, 6 ± 0.06 mm [0.250 ± 0.003 in.] in diameter, centered by length to within 0.12 mm [0.005 in.] and by width to within 0.05 mm [0.002 in.]. While tabs may be used, they are not required and generally not needed, since the open hole acts as sufficient stress riser to force failure in the notched region. Configuration B is limited to quasi-isotropic laminate stacking sequences, typically a $[45_m/-45_m/0_m/90_m]_{ns}$ tape or $[45_m/0_m]_{ns}$ fabric laminate, with a specimen grip length of 35 to 55 mm [1.4 to 2.0 in.].

NOTE 3—The ungripped specimen length for Configuration B shall not be less than 75 mm [3.0 in.] as shorter ungripped lengths may result in an unacceptable influence upon failure at or near to the hole.

8.3 *Specimen Preparation*—Special care shall be taken to ensure that creation of the specimen hole does not delaminate or otherwise damage the material surrounding the hole. Holes should be drilled undersized and reamed to final dimensions. Record and report the specimen hole preparation methods. Other specimen preparation techniques and requirements are noted in Test Method [D3039/D3039M](#).

9. Calibration

9.1 Calibration shall be in accordance with Test Method [D3039/D3039M](#).

10. Conditioning

10.1 The recommended pre-test condition is effective moisture equilibrium at a specific relative humidity as established by Test Method [D5229/D5229M](#); however, if the test requestor does not explicitly specify a pre-test conditioning environment, no conditioning is required and the test specimens may be tested as prepared.

10.2 The pre-test specimen conditioning process, to include specified environmental exposure levels and resulting moisture content, shall be reported with the test data.