



Designation: ~~D2712~~—~~18~~ **D2712 – 18a**

Standard Test Method for Determination of Hydrocarbon Impurities in High Purity Propylene by Gas Chromatography¹

This standard is issued under the fixed designation D2712; the number immediately following the designation indicates the year of original adoption or, in the case of revision, the year of last revision. A number in parentheses indicates the year of last reapproval. A superscript epsilon (ϵ) indicates an editorial change since the last revision or reapproval.

NOTE—~~Previously balloted and approved material was included and the year date changed on January 19, 2018.~~

1. Scope*

1.1 This test method is used for the determination of hydrocarbon impurities in propylene (propene) material of 97 % by mass or greater purity (concentrates). These impurities are determined in the concentration range of 0.35 mg/kg to 8575 mg/kg and includes the following components: methane, ethane, ethylene, propane, acetylene, isobutane, propadiene, normal butane, trans-2-butene, butene-1, isobutylene, cis-2-butene, isopentane, methylacetylene, normal pentane, and 1,3-butadiene.

NOTE 1—Optionally, the analysis may include the determination of pentenes/hexanes and heavier components, see 6.3.

1.2 This test method does not determine non-hydrocarbon impurities, and additional tests may be necessary to fully characterize the propylene sample. However, for the purposes of this test, the purity of propylene is determined as the difference between the total of the determined analytes and 100 % (by difference).

1.3 When this test method is being used for the determination of trace level impurities in high-purity propylene, the use of this test method for the analysis of propylene samples at lower purities is not recommended due to the potential for cross contamination between samples.

1.4 The values stated in SI units are to be regarded as standard. No other units of measurement are included in this standard.

1.5 *This standard may involve hazardous materials, operations, and equipment. This standard does not purport to address all of the safety concerns, if any, associated with its use. It is the responsibility of the user of this standard to establish appropriate safety, health, and environmental practices and determine the applicability of regulatory limitations prior to use.*

1.6 *This international standard was developed in accordance with internationally recognized principles on standardization established in the Decision on Principles for the Development of International Standards, Guides and Recommendations issued by the World Trade Organization Technical Barriers to Trade (TBT) Committee.*

2. Referenced Documents

2.1 *ASTM Standards:*²

D1265 Practice for Sampling Liquefied Petroleum (LP) Gases, Manual Method

D3700 Practice for Obtaining LPG Samples Using a Floating Piston Cylinder

F307 Practice for Sampling Pressurized Gas for Gas Analysis

3. Terminology

3.1 *Definitions:*

3.1.1 *liquefied petroleum gas (LPG)*—hydrocarbon gases that can be stored or handled in the liquid phase under moderate conditions of pressure and at ambient temperature; they consist essentially of C₃ and C₄ alkanes and alkenes, or mixtures of these, and contain generally less than 0.5 % by liquid volume of material of higher carbon number, and have a vapor pressure not exceeding 2000 kPa at 40 °C.

3.1.2 *propylene concentrate*—material-containing propylene at or above concentrations of 97 % by mass.

¹ This test method is under the jurisdiction of ASTM Committee D02 on Petroleum Products, Liquid Fuels, and Lubricants and is the direct responsibility of Subcommittee D02.D0.03 on Propylene.

Current edition approved Jan. 19, 2018; June 1, 2018, Published January 2018/July 2018. Originally approved in 1968. Last previous edition approved in 2017/2018 as D2712 – 17/18, ϵ . DOI: 10.1520/D2712-18; 10.1520/D2712-18A.

² For referenced ASTM standards, visit the ASTM website, www.astm.org, or contact ASTM Customer Service at service@astm.org. For *Annual Book of ASTM Standards* volume information, refer to the standard's Document Summary page on the ASTM website.

*A Summary of Changes section appears at the end of this standard

4. Summary of Test Method

4.1 An LPG phase sample is analyzed as received via either gas or liquid sampling valves into a gas chromatograph. The gas chromatograph is provided with a liquid sampling valve and optionally with a 6-port gas sampling valve and/or a 6-port switching valve. If the user chooses to use a 6-port switching valve to provide an initial composite backflush of C₅ olefins and C₆+ components, a small length of pre-column should be used to provide separation of the components of interest, as listed in 1.1, and the heavier components. This pre-column will separate the heaviest components from the remainder of the sample. A pre-column which also retains water and oxygenated hydrocarbons is recommended. A flame ionization detector (FID) is used for component detection. However, other detectors may be used provided that they can provide the same sensitivity and selectivity for the components of interest.

4.2 The integrated detector signal (peak areas) is corrected for detector response by comparing sample peak areas for each compound of interest relative to peak areas obtained for each compound of interest from a standard mixture of known component concentrations. This method of calibration shall be referred to hereafter as “external standard calibration.”

5. Significance and Use

5.1 High-purity propylene is required as a feedstock for various manufacturing processes, and the presence of trace amounts of certain hydrocarbon impurities may have adverse effects on yield or catalyst life. This test method is suitable for use as a benchmark in setting commercial specifications, for use as an internal quality control tool, and for use in development or research work.

6. Apparatus

6.1 *Gas Chromatograph (GC)*—Any gas chromatographic instrument that is capable of providing a linear temperature programmed zone for the capillary column(s). The programming rate must be sufficiently repeatable to obtain a retention time repeatability of 0.05 min (3 s) throughout the scope of this analysis.

6.2 *Detector*—Any detector providing a sensitivity of 0.5 mg/kg or less for the compounds listed in 1.1 may be used. The use of a flame ionization detector (FID) is strongly recommended. However, other detectors may be used provided that they can provide the same sensitivity and selectivity for the components of interest without interference from the propylene major peak or non-hydrocarbon components, which might be present in the samples. As an example, the use of a mass spectroscopic detector (MSD), a discharge ionization detector (DID), or helium ionization detector (HID) might be possible so long as appropriate valving is supplied and/or appropriate testing is performed to ensure that non-hydrocarbon components will not interfere. All calculations in this test method are based on the use of a flame ionization detector (FID).

6.3 *Column(s)*—The recommended analytical column is a 50 m by 0.53 mm I.D. KCl deactivated Al₂O₃ PLOT column. Relative retention order is dependent upon the deactivation method of the column. Users are cautioned to specifically test the column using a test mix to ensure that propadiene, methyl acetylene, and butadiene are not being adsorbed by the column. This condition can exist depending upon the degree of column deactivation. Other types of columns may be used so long as they provide sufficient separation and no absorption of propadiene, methyl acetylene, or butadiene occurs.

6.4 *Inlet*—The gas chromatograph must include a splitter inlet, which may be operated isothermally at user-settable temperatures up to the maximum column temperature employed. Split flows in the range of 5:1 to 8:1 might be employed; a typical value for the split ratio is 5:1 using a 0.2 µL liquid sampling valve injection (to allow the lower detection limits described to be obtained). The splitter inlet is used in conjunction with gas or liquid sampling valves, as described below.

6.4.1 The user may wish to incorporate the use of a 6-port switching valve and pre-column(s) to provide an initial C₅ olefin/C₆+ composite backflush. Any pre-columns which provide separation between the components of interest and the composite heavier components may be used. A 10 m to 15 m section of 0.53 mm I.D. by 3 micro polydimethylpolysiloxane is recommended. The length of a pre-column will be dependent upon the film thickness, phase, and/or column activity. This pre-column separates the heaviest components away from the remainder of the sample.

6.5 Sample Introduction:

6.5.1 *Liquid Sampling*—Liquid samples shall be injected by means of a liquid sampling valve with an internal fixed sample loop which will provide the minimum detection limits as specified in 1.1. A sample loop size of 0.2 µL has been found to be sufficient. The liquid sample being introduced must be pressurized at least 1380 kPa above the vapor pressure of the sample at the valve temperature at all times (use of a constant pressure source is suggested, if possible). It is important that this pressure be duplicated to ensure repeatability. A shut-off valve or back-pressure regulator should be located at the waste exit of the liquid sampling valve so that sample pressure to the valve may be maintained.

6.5.1.1 *Figs. 1 and 2*—A frit type filter should be placed in the sample line in front of the liquid sampling valve so that particulates that might be present in samples will not score the valve rotor. A frit size of 2 µm to 7 µm is suggested. It is very important that the filter has a low-pressure drop. A high-pressure drop across a filter will cause the sample to boil across the filter, causing non-repeatable results. The liquid sample valve shall be mounted exterior to any heated compartment and shall be able to operate at ambient temperature. The use of floating piston sample cylinders is encouraged to minimize or eliminate the

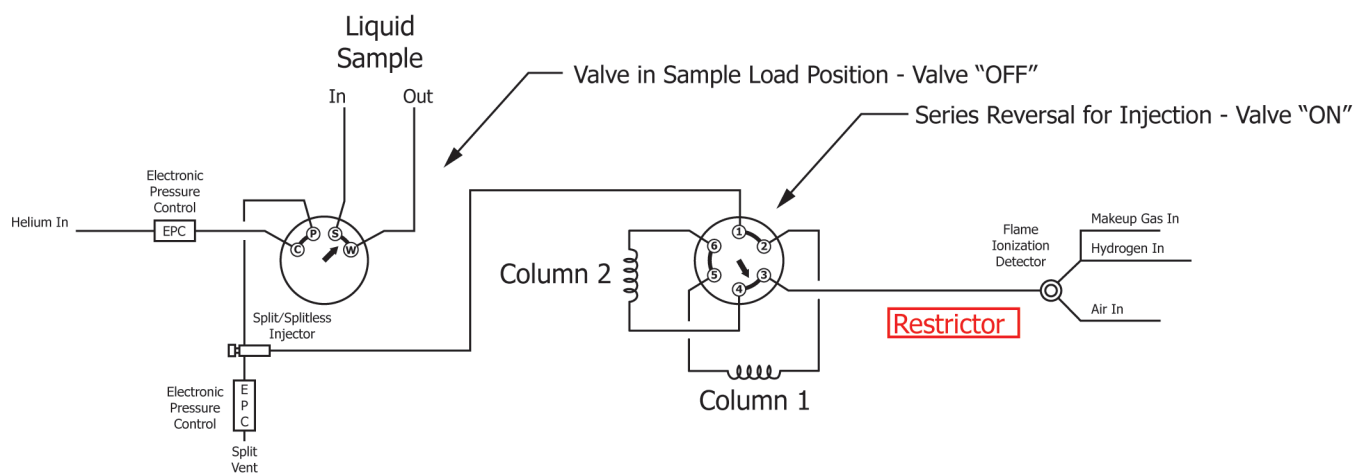

FIG. 1 Arrangement of Valves

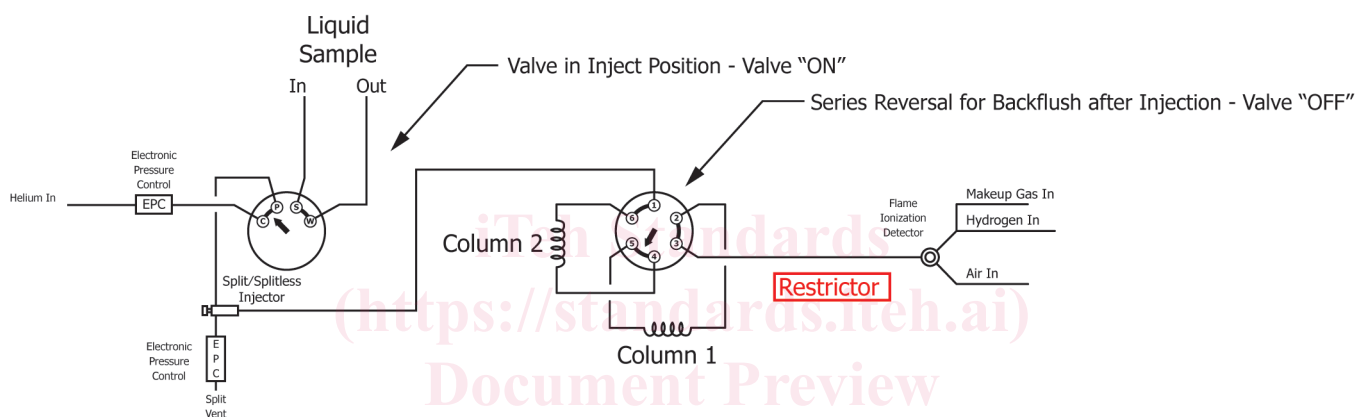

FIG. 2 Arrangement of Valves

ASTM D2712-18a

<https://standards.iteh.ai/catalog/standards/sist/edface24-ea4d-487c-b6d2-610333e7ab8e/astm-d2712-18a>

volatilization of lighter components into the headspace. The fixed sample volume injection should be repeatable such that successive runs agree within 2 % relative on each component area and all components are within the linearity of the detector. (2 % relative on each component is not achieved in the precision data set of this test method for ethylene > 5 % and acetylene >3.5 %)

6.5.2 *Vapor Sampling (optional)*—A six-port gas sampling valve with 1.5875 mm (1/16 in.) fittings and a 200 µL fixed sampling loop may be used to sample propene concentrates in the vapor phase. If a gas-sampling valve is used, the use of a 2 µm to 7 µm filter is advised to prevent scoring the valve rotor. The filter may be a frit or packed screen type. The gas-sampling valve must be housed in a thermostatically controlled compartment. Special care must be taken to vaporize liquid phase sample rather than sampling the headspace of the liquid. The sample valve should be repeatable such that successive runs agree within 2 % relative on each component and all components are within the linearity of the detector.

6.5.2.1 An in-line, heated vaporizing device, which is heat-traced to the gas-sampling valve, may be used. The device should consist of a volume of tubing of approximately 10 mL, which is encased in a heated block (the block should be a high-mass block heated to approximately 80 °C). The outlet of the tubing should be heat-traced and connected to the gas-sampling valve. Other types of commercially available vaporizers may be used.

6.5.3 *Series/Reversal Switching (optional)*—A six-port switching valve with 1.5875 mm (1/16 in.) fittings may be used in combination with the analytical column and pre-column. A typical arrangement of the valves is shown in Fig. 1 and Fig. 2, or in Fig. 3 and Fig. 4 if the gas sampling valve is used. To avoid scoring the valve rotor, it is suggested that the connections to the analytical column and pre-column be made using 1.5875 mm tubing from the valves through zero-volume unions to the capillaries. Plumbing techniques must be used which avoid dead-volumes and cold spots. The timing of the valve switch must be empirically determined using a sample mixture, which contains 1,3-butadiene, n-pentane, and n-hexane. It will be necessary to maximize the area counts of 1,3-butadiene and n-pentane while not allowing n-hexane to elute from the analytical column. The timing will depend upon the length of pre-column that is used, the phase and film thickness of that column, and/or the activity of that column.

6.6 *Data Acquisition*—Any integrator or computerized data acquisition system may be used for peak area integration and for graphic presentation of the chromatogram.

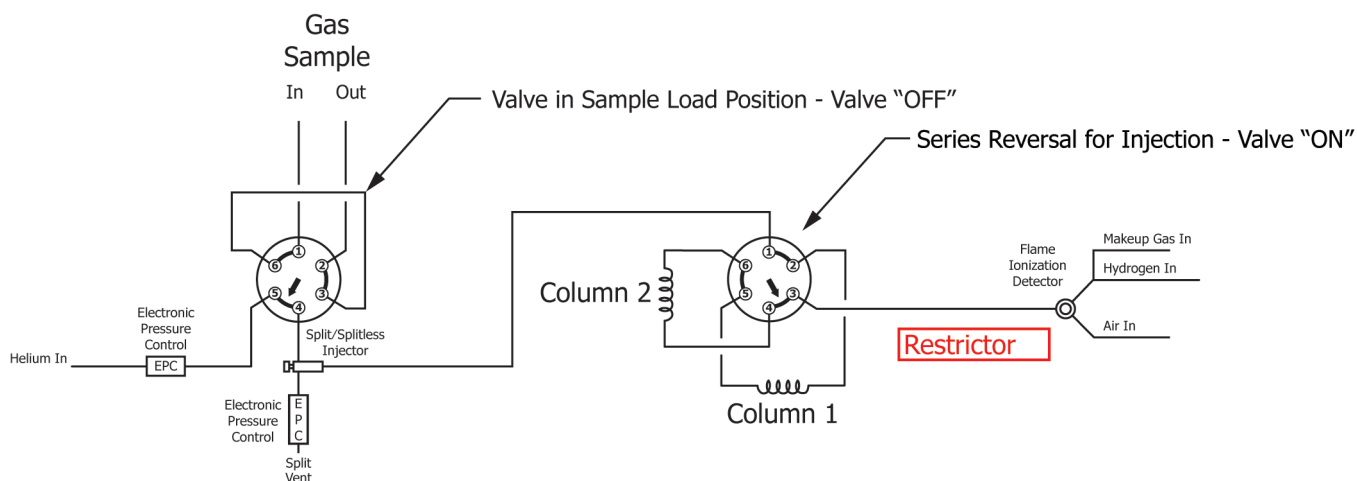

FIG. 3 Arrangement of Valves (Gas Sampling Valve Included)

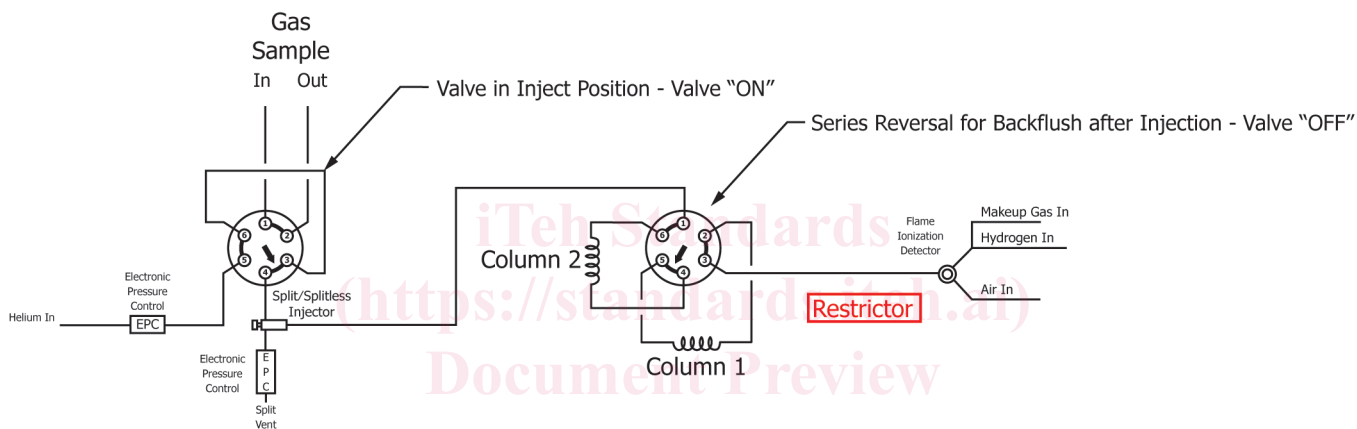

FIG. 4 Arrangement of Valves (Gas Sampling Valve Included)

7. Reagents and Materials

7.1 *Calibration Standard Mixture*—A liquid sample containing levels of 2 mg/kg to 20 mg/kg of each of the trace components (all components except propane at 3000 mg/kg to 5000 mg/kg and propene balance) listed in **Table 1** should be used as the external standard by which the instrument will be calibrated. It is strongly recommended that the calibration standard mixture be contained in a floating piston cylinder and pressurized at least 1380 kPa above the vapor pressure of the mixture at all times (a constant

TABLE 1 Typical Compounds and Retention Times for Common Hydrocarbon Impurities in Propylene

Components	~Retention Time (minutes)
C ₅ /C ₆ ⁺ composite backflush	2.2
Methane	3.9
Ethane	4.6
Ethylene	5.4
Propane	7.2
Propylene	8.8
Acetylene	10.8
Isobutane	11.2
Propadiene	11.4
Normal Butane	11.6
Trans-2-Butene	13.9
Butene-1	14.1
Isobutylene	14.5
Cis-2-Butene	14.9
Isopentane	16.2
Methylacetylene	16.4
Normal Pentane	16.7
1,3-Butadiene	17.3
3-Methyl-1-Butene	18.3