



Designation: E279 – 18

Standard Test Method for Determination of Abrasion Resistance of Iron Ore Pellets, Lump, and Sinter by the Tumbler Test¹

This standard is issued under the fixed designation E279; the number immediately following the designation indicates the year of original adoption or, in the case of revision, the year of last revision. A number in parentheses indicates the year of last reapproval. A superscript epsilon (ϵ) indicates an editorial change since the last revision or reapproval.

1. Scope

1.1 This test method covers a relative measure of the resistance of iron ore pellets, lump, and sinter to degradation by impact and by abrasion.

1.2 The values stated in SI units are to be regarded as standard. The values given in parentheses are mathematical conversions to inch-pound units that are provided for information only and are not considered standard.

1.3 Results given by this test method should be similar to those from ISO 3271 (see [Appendix X1](#) for details).

1.4 *This standard does not purport to address all of the safety concerns, if any, associated with its use. It is the responsibility of the user of this standard to establish appropriate safety, health, and environmental practices and determine the applicability of regulatory limitations prior to use.*

1.5 *This international standard was developed in accordance with internationally recognized principles on standardization established in the Decision on Principles for the Development of International Standards, Guides and Recommendations issued by the World Trade Organization Technical Barriers to Trade (TBT) Committee.*

2. Referenced Documents

2.1 ASTM Standards:²

[E29 Practice for Using Significant Digits in Test Data to Determine Conformance with Specifications](#)

[E135 Terminology Relating to Analytical Chemistry for Metals, Ores, and Related Materials](#)

[E276 Test Method for Particle Size or Screen Analysis at No. 4 \(4.75-mm\) Sieve and Finer for Metal-Bearing Ores and Related Materials](#)

[E389 Test Method for Particle Size or Screen Analysis at No. 4 \(4.75-mm\) Sieve and Coarser for Metal-Bearing Ores and Related Materials](#)

[E877 Practice for Sampling and Sample Preparation of Iron Ores and Related Materials for Determination of Chemical Composition and Physical Properties](#)

[E882 Guide for Accountability and Quality Control in the Chemical Analysis Laboratory](#)

2.2 ISO Standards:³

[ISO 3271 Iron ores for blast furnace and direct reduction feedstocks – Determination of the tumble and abrasion indices](#)

3. Terminology

3.1 *Definitions*—For definitions of terms used in this test method, refer to Terminology [E135](#).

4. Summary of Test Method

4.1 The sample is placed in a tumbler drum which is rotated. The tumbled material is removed and screened to determine the degradation.

5. Significance and Use

5.1 This test method is a comparative method intended primarily to test materials for compliance with compositional specifications or for monitoring. It is assumed that all who use these procedures will be trained analysts capable of performing common laboratory procedures skillfully and safely. It is expected that work will be performed in a properly equipped laboratory and that proper waste disposal procedures will be followed. Appropriate quality control practices must be followed such as those described in Guide [E882](#).

5.2 This test method is used to monitor the feed to blast furnaces and gas-based direct reduction plants for process control.

6. Apparatus

6.1 *Tumbler Apparatus*, as shown in [Fig. 1](#), shall be a circular drum 914 mm (36 in.) in inside diameter and 457 mm

¹ This test method is under the jurisdiction of ASTM Committee E01 on Analytical Chemistry for Metals, Ores, and Related Materials and is the direct responsibility of Subcommittee E01.02 on Ores, Concentrates, and Related Metallurgical Materials.

Current edition approved April 1, 2018. Published June 2018. Originally approved in 1965. Last previous edition approved in 2010 as E279 – 97 (2010). DOI: 10.1520/E0279-18.

² For referenced ASTM standards, visit the ASTM website, www.astm.org, or contact ASTM Customer Service at service@astm.org. For *Annual Book of ASTM Standards* volume information, refer to the standard's Document Summary page on the ASTM website.

³ Available from International Organization for Standardization (ISO), ISO Central Secretariat, BIBC II, Chemin de Blandonnet 8, CP 401, 1214 Vernier, Geneva, Switzerland, <http://www.iso.org>.

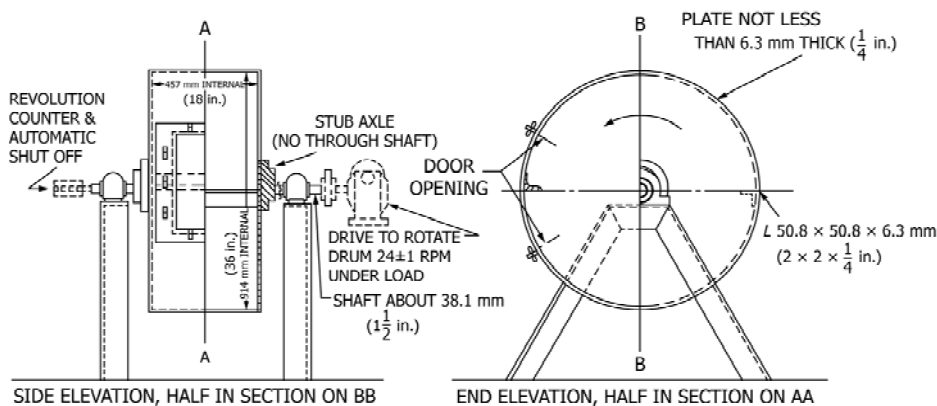

FIG. 1 Tumbler Test Apparatus

(18 in.) in inside length constructed of steel plate at least 6.3 mm ($\frac{1}{4}$ in.) in thickness. The drum shall be replaced whenever the thickness of the plate is reduced by wear to 3.18 mm ($\frac{1}{8}$ in.) in any area. Two equally spaced steel angle lifters, 50.8 mm by 50.8 mm by 6.3 mm (2 in. by 2 in. by $\frac{1}{4}$ in.) shall be solidly attached longitudinally inside the drum by riveting in such a manner as to prevent accumulation of material between the lifter and drum. Preferably, one of the lifters shall be attached to the door for ease of sample removal. The lifters shall be fastened so that the attached legs point away from the direction of rotation, thus giving a clear unobstructed shelf for lifting the sample. The lifters shall be replaced when the wear is such that the shelf measures less than 47.6 mm ($1\frac{7}{8}$ in.). The door shall be so constructed as to fit into the drum to form a smooth inner surface and during the test shall be rigidly fastened to prevent any loss of the sample. The drum shall be rotated on stub axles about 38.1 mm ($1\frac{1}{2}$ in.) in diameter attached to the ends of the drum by means of flanges welded or bolted so as to provide smooth inner surfaces. The apparatus shall be fitted with a revolution counter and, preferably, with an automatic device to stop the drum after 200 revolutions.

6.2 *Sieves*—Square-mesh sieves having the following designations are needed: 50-mm (2-in.); 37.5-mm ($1\frac{1}{2}$ -in.); 19-mm ($\frac{3}{4}$ -in.); 12.5-mm ($\frac{1}{2}$ -in.); 9.5-mm ($\frac{3}{8}$ -in.); 6.3-mm ($\frac{1}{4}$ -in.); and 600- μ m (No. 30, 0.0232-in.).

6.3 *Scales*—The scales used for weighing the sample shall be sensitive to 23 g (0.05 lb).

6.4 *Riffle*—The riffle shall have a 37.5-mm ($1\frac{1}{2}$ -in.) opening.

7. Preparation of Sample

7.1 *Sample Size and Size Distribution*—All samples must be split to make representative samples of the appropriate size. This is typically done using a riffler. See Practice E877 for details on proper riffler selection and use.

7.1.1 Pellets:

7.1.1.1 A gross sample of the pellets must be collected. Sample size shall be sufficient to obtain approximately 45.4-kg (100-lb) of pellets that will pass a 37.5-mm ($1\frac{1}{2}$ -in.), and be retained on a 6.3-mm ($\frac{1}{4}$ -in.) square-mesh sieve. For pellets with more than 10 % larger than 12.7-mm ($\frac{1}{2}$ -in.) the riffle

opening should be three times larger than the largest single pellet to pass through the riffle.

7.1.1.2 Use an 11.3-kg \pm 0.23-kg (25-lb \pm 0.5-lb) sample of 38.1-mm by 6.3-mm ($1\frac{1}{2}$ -in. by $\frac{1}{4}$ -in.) pellets dried to constant mass at 105 °C to 110 °C for each test. Prepare by riffling the gross sample of pellets retained on the 6.3-mm ($\frac{1}{4}$ -in.) sieve to 11.3 kg (25 lb).

7.1.2 Sinter/Lump:

7.1.2.1 The gross sample of the sinter or lump must be collected. Sample size shall be sufficient to obtain approximately 45.4-kg (100-lb) of sinter or lump that will pass a 50-mm (2-in.), and be retained on a 9.5-mm ($\frac{3}{8}$ -in.) square-mesh sieve.

7.1.2.2 Use an 11.3-kg \pm 0.23-kg (25-lb \pm 0.5-lb) sample of 50.8-mm by 9.51-mm (2-in. by $\frac{3}{8}$ -in.) sinter or lump. Prepare by taking proportionate masses of each size according to the screen analysis made by sieving the gross sample through 50-mm (2-in.), 19.0-mm ($\frac{3}{4}$ -in.), 12.5-mm ($\frac{1}{2}$ -in.), and 9.5-mm ($\frac{3}{8}$ -in.) sieves in accordance with Test Method E389.

8. Procedure

8.1 Place the 11.3-kg (25-lb) sample into the tumbler drum. Rigidly fasten the door and rotate the drum at 24 rpm \pm 1 rpm for a total of 200 revolutions. Then remove all of the material from the drum and hand sieve it on 6.3-mm ($\frac{1}{4}$ -in.) and 600- μ m (No. 30, 0.0232-in.) sieves. Separately weigh and record the amount of sample retained on the 6.3-mm ($\frac{1}{4}$ -in.) sieve, the amount retained on the 600- μ m (No. 30, 0.0232-in.) sieve, and the amount passing the 600- μ m (No. 30, 0.0232-in.) sieve in accordance with Test Methods E276 and E389. Mechanical sieving may be used, provided it has been established that the method gives the same results as hand sieving.

9. Number of Tests

9.1 At least two tests shall be made on each pellet sample. If the differences between the values obtained exceed 0.4 units in the cumulative percentage over the 6.3-mm ($\frac{1}{4}$ -in.) or the 600- μ m (No. 30, 0.0232-in.) sieve, at least one further test shall be made and the mean value of all tests taken.

9.2 At least two tests shall be made on each sinter/lump sample. If the differences between the values obtained exceed