



Designation: **E28—14 E28 – 18**

Standard Test Methods for Softening Point of Resins Derived from Pine Chemicals and Hydrocarbons, by Ring-and-Ball Apparatus¹

This standard is issued under the fixed designation E28; the number immediately following the designation indicates the year of original adoption or, in the case of revision, the year of last revision. A number in parentheses indicates the year of last reapproval. A superscript epsilon (ϵ) indicates an editorial change since the last revision or reapproval.

This standard has been approved for use by agencies of the U.S. Department of Defense.

1. Scope

1.1 These test methods are intended for determining the softening point of resins (including rosin and terpene resins) and similar materials by means of the ring-and-ball apparatus.

NOTE 1—For testing asphalts, tars, and pitches, see Test Method [D36](#).

1.1.1 Test method using the automated ring and ball softening point apparatus is the reference method and the test method using the manual ring and ball method is an alternative method.

~~1.1.2 Test method using the manual ring and ball softening point apparatus is an alternative method.~~

1.2 The values stated in SI units are to be regarded as the standard. The values given in parentheses are for information only.

1.3 *This standard does not purport to address all of the safety concerns, if any, associated with its use. It is the responsibility of the user of this standard to establish appropriate ~~safety~~ safety, health, and ~~health~~ environmental practices and determine the applicability of regulatory limitations prior to use.*

1.4 *This international standard was developed in accordance with internationally recognized principles on standardization established in the Decision on Principles for the Development of International Standards, Guides and Recommendations issued by the World Trade Organization Technical Barriers to Trade (TBT) Committee.*

2. Referenced Documents

2.1 *ASTM Standards:*²

[D36](#) Test Method for Softening Point of Bitumen (Ring-and-Ball Apparatus)

[E1](#) Specification for ASTM Liquid-in-Glass Thermometers

[E177](#) Practice for Use of the Terms Precision and Bias in ASTM Test Methods

[E691](#) Practice for Conducting an Interlaboratory Study to Determine the Precision of a Test Method

3. Significance and Use

3.1 In general, with materials of these types, softening does not take place at a definite temperature. As the temperature rises, these materials gradually change from brittle or exceedingly thick and slow-flowing materials to softer and less viscous liquids. For this reason, the determination of the softening point must be made by a fixed, arbitrary, and closely defined method if the results obtained are to be comparable.

3.2 In these test methods, the softening point is defined as the temperature at which a disk of the sample held within a horizontal ring is forced downward a distance of 25.4 mm (1 in.) under the weight of a steel ball as the sample is heated at 5°C/min in a water, glycerin, silicone oil, ethylene glycol/water or glycerin/water bath.

3.3 The automatic method was chosen to be the reference method because a round robin demonstrated that it gave more precise results than the manual method.

¹ These test methods are under the jurisdiction of ASTM Committee [D01](#) on Paint and Related Coatings, Materials, and Applications and are the direct responsibility of Subcommittee [D01.34](#) on Pine Chemicals and Hydrocarbon Resins.

Current edition approved July 1, 2014 July 1, 2018. Published August 2014 July 2018. Originally approved in 1936. Last previous edition approved in 2009 2014 as ~~E28—99~~ (2009) E28 – 14. DOI: ~~10.1520/E0028-14~~ 10.1520/E0028-18.

² For referenced ASTM standards, visit the ASTM website, www.astm.org, or contact ASTM Customer Service at service@astm.org. For *Annual Book of ASTM Standards* volume information, refer to the standard's Document Summary page on the ASTM website.

4. Sample Preparation

4.1 Preparation of Sample by the Pour Method:

4.1.1 This procedure is suitable for materials that can be heated and poured without adverse effects on the softening point.

4.1.2 Select a sample representative of the material to be tested. The sample should consist of flakes, pastilles, or freshly broken lumps free of oxidized surfaces. Avoid inclusion of finely divided material or dust.

4.1.3 Select a quantity at least twice that necessary to fill the desired number of rings, and melt it immediately in a clean container, using an oven, hot plate, sand bath or oil bath to prevent local overheating. Take care to avoid incorporating air bubbles in the sample. Melt the sample completely, but do not heat it above a temperature necessary to pour the material readily. The time from the beginning of heating to the pouring of the sample should not exceed 15 min.

iTeh Standards
(<https://standards.iteh.ai>)
Document Preview

[ASTM E28-18](#)

<https://standards.iteh.ai/catalog/standards/sist/3dcb184-3ec8-4835-a91e-430ff79aff42/astm-e28-18>

NOTE 2—For materials that may be heat sensitive, continuously inert the flask containing the test specimen with nitrogen (N_2) during the remelting procedure.

4.1.4 For materials that tend to crack or shrink in the ring on cooling, immediately before filling the ring, preheat the ring to approximately the temperature at which the material is to be poured. The ring, while being filled, should rest bottom down on a suitable metal surface. Pour the sample into the ring so as to leave an excess on cooling. After cooling a minimum of 30 min, trim off the excess resin on the periphery of the ring. To remove excess resin from the top, cut the excess material off cleanly with a slightly heated knife or spatula, or grasp the ring in a pair of tongs and draw the top surface quickly and firmly over the surface of a heated metal plate. In case the test is repeated, use a clean container and fresh sample.

5. Reagents and Materials

5.1 Bath Liquids:

5.1.1 *Distilled or Deionized Water, Freshly Boiled*—For softening points between 35°C (95°F) and 80°C (176°F).

5.1.1.1 Use distilled or deionized water that has been cooled to at least 27°C (81°F) below the anticipated softening point, but in no case lower than 5°C (41°F).

5.1.2 *USP Glycerin*—For softening points between 80°C (176°F) and 150°C (302°F). Repeated use of glycerin will increase the moisture content over time and may affect results. Replace with fresh glycerin if any change in appearance is noted.

NOTE 3—Glycerin should not be used for softening points greater than 150°C (302°F) due to the 160°C (320°F) flash point of glycerin.

5.1.3 *Silicone Oil (Polydimethylsiloxane)*—For softening points above 80°C (176°F). The silicone oil must have a temperature range of 200°C + (392°F), remain clear within the temperature range, have no apparent reactivity with the test specimen, have a high water repellency, and maintain a uniform viscosity and stirring rate within the temperature range.³

NOTE 4—Replace with fresh silicone oil if any change in appearance is noted. Do not use silicone oil that contains any gels; gels are an indicator that degradation has occurred.

5.1.4 *Ethylene Glycol/Water*—For softening points up to 35°C (95°F).

5.1.4.1 Prepare a fresh 50/50 (v/v) mixture of distilled water and ethylene glycol prior to sample analysis. For softening points between 0°C and 35°C, a 50/50 (v/v) mixture of glycerin and water may be used.

REFERENCE METHOD AUTOMATED RING AND BALL SOFTENING POINT METHOD

6. Apparatus

6.1 *Automated Ring and Ball-Softening Point Instrument with Control Unit*, test units, and test inserts.

6.2 *Ring*—A brass, shouldered ring conforming to the dimensions shown in Fig. 1(a).

6.3 *Ball*—A steel ball, 9.53 ± 0.1 mm ($\frac{3}{8}$ in.) in diameter, weighing between 3.45 and 3.55 g.^{9aff42/astm-e28-18}

6.4 *Beaker*, 600 mL or what is recommended by the manufacturer. Ensure that the dimensions will properly fit the heating unit.

6.5 *Stir Bar*—The dimensions must be such that the bar spins freely under the test stand. It is recommended that the stirring bar supplied with the instrument be used or one that has been shown to give the same result as the one supplied.

7. Procedure for Materials Having a Softening Point Between 35°C (95°F) and <80°C (176°F)

7.1 Add a stir bar to the 600-mL beaker and fill with approximately 500 mL of distilled or deionized water, conforming to the requirements in 5.1.1. Ensure that the beaker is properly positioned on the heater in the test unit. Place the prepared sample rings in the test insert. Place the ball-centering guide and ball on top of the sample ring. Place the test insert in the beaker of water, suspending it from the support pins. Place the temperature measuring device in the test insert. Verify that the control unit is set for the correct bath liquid.

7.2 *Heating*—Heat the bath so that the temperature of the water is raised uniformly at a rate of 5°C (10°F)/min. Protect the bath from drafts, using shields if necessary. The maximum permissible variation for any one min. period after the first three min. is $\pm 0.5^\circ\text{C}$ ($\pm 1^\circ\text{F}$). Reject any test in which the rate of temperature rise does not fall within these limits. The test is complete when the light beam has been interrupted by the falling ball and material.

NOTE 5—Rigid adherence to the prescribed rate of heating is absolutely essential for reproducibility of results.

7.3 *Softening Point*—Record as the softening point the temperature displayed on the unit after the light beam has been interrupted by the falling ball and material.

³ The sole source of supply of silicone oil, 200 fluid, 50 cSt viscosity known to the committee at this time is Dow Corning Corp., Midland, MI 48686. If you are aware of alternative suppliers, please provide this information to ASTM International Headquarters. Your comments will receive careful consideration at a meeting of the responsible technical committee,¹ which you may attend.

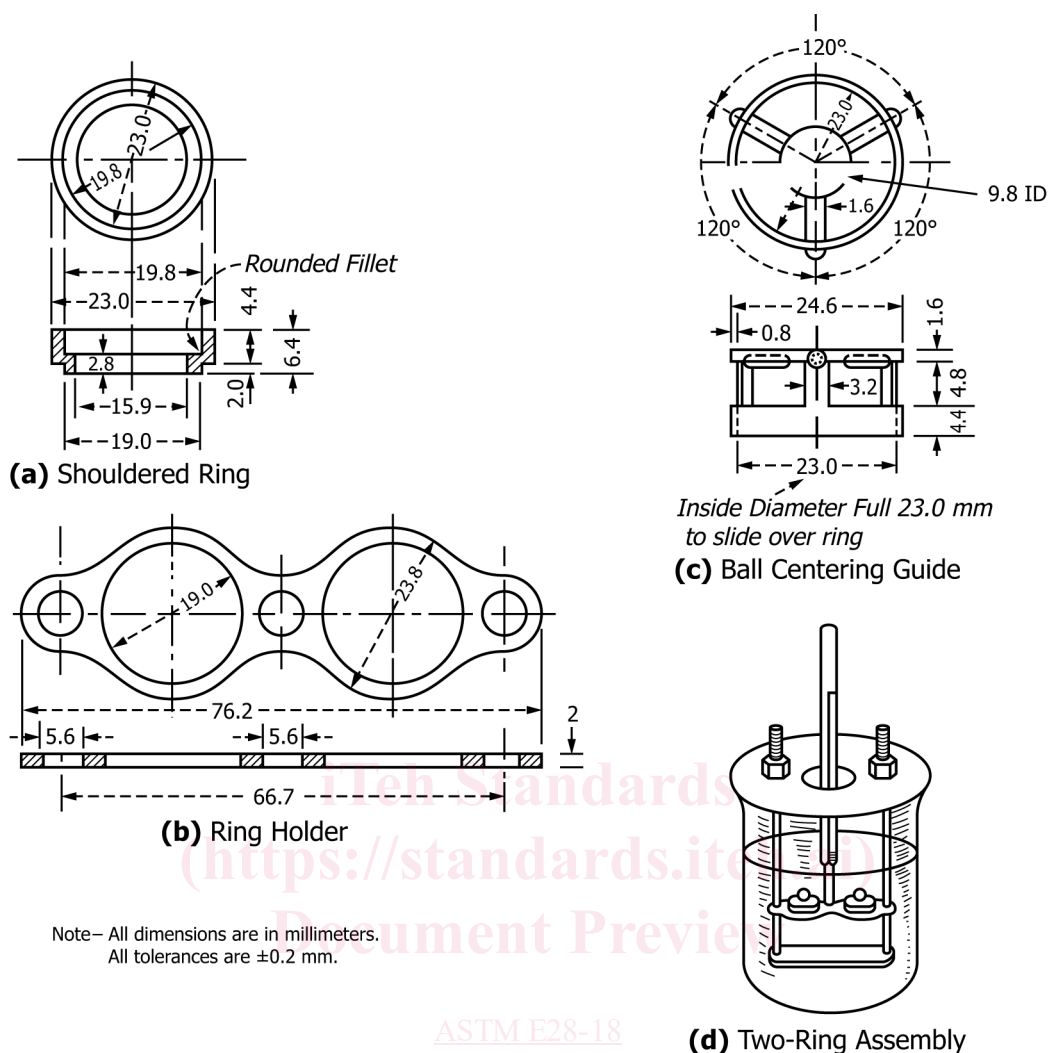

FIG. 1 Shouldered Ring, Ring Holder, Ball-Centering Guide, and Assembly of Apparatus Showing Two Rings

7.4 Start the cooling process in the instrument. Remove the temperature measuring device from the test insert, then remove the test insert from the beakers. Thoroughly clean the test insert, ball, and ring in a suitable solvent.

8. Calibration

8.1 The calibration of any automated ring and ball-softening point apparatus must be performed on a regular basis since accurate temperature control is required. Follow the manufacturer's instructions for calibration of the instrument.

9. Procedure for Materials Having Softening Points Between 80°C (176°F) and 150°C (302°F)

9.1 Use the same procedure as described in Section 7, except fill the bath with glycerin or silicone oil.

NOTE 6—For materials softening around 80°C (176°F), report the bath liquid since a glycerin or silicone oil bath will yield a slightly higher result than a water bath.

10. Procedure for Materials Having Softening Points Above 150°C (302°F)

10.1 Use the same procedure as described in Section 7, except fill the bath with silicone oil (Note 3).

11. Procedure for Materials Having Softening Points Below 35°C (95°F)

11.1 Apparatus:

11.1.1 Freezer or Isopropyl Alcohol Dry-Ice Bath.

11.2 Procedure:

11.2.1 Cool the bath, described in 5.1.4.1, to -25°C (-13°F) in the precooled freezer or an isopropyl alcohol dry-ice bath.