



Designation: D2402 – 07 (Reapproved 2018)

## Standard Test Method for Water Retention of Textile Fibers (Centrifuge Procedure)<sup>1</sup>

This standard is issued under the fixed designation D2402; the number immediately following the designation indicates the year of original adoption or, in the case of revision, the year of last revision. A number in parentheses indicates the year of last reapproval. A superscript epsilon ( $\epsilon$ ) indicates an editorial change since the last revision or reapproval.

### 1. Scope

1.1 This test method covers the measurement of water retention of man-made and natural fibers as staple, tow, or filament and spun yarns. It is intended to give a measure of the amount of water which cannot be removed from thoroughly wetted fiber solely by mechanical means as applied by centrifugal force (see 3.2).

1.2 *This standard does not purport to address all of the safety concerns, if any, associated with its use. It is the responsibility of the user of this standard to establish appropriate safety, health, and environmental practices and determine the applicability of regulatory limitations prior to use.* For specific precautionary statements, see Section 9.

1.3 *This international standard was developed in accordance with internationally recognized principles on standardization established in the Decision on Principles for the Development of International Standards, Guides and Recommendations issued by the World Trade Organization Technical Barriers to Trade (TBT) Committee.*

### 2. Referenced Documents

2.1 *ASTM Standards:*<sup>2</sup>

- D123 Terminology Relating to Textiles
- D629 Test Methods for Quantitative Analysis of Textiles
- D2258/D2258M Practice for Sampling Yarn for Testing
- D3333 Practice for Sampling Manufactured Staple Fibers, Sliver, or Tow for Testing
- D4849 Terminology Related to Yarns and Fibers

### 3. Terminology

3.1 For all terminology relating to D13.58, Yarns and Fibers, refer to Terminology D4849.

3.1.1 The following terms are relevant to this standard: moisture pick-up, water retention.

<sup>1</sup> This test method is under the jurisdiction of ASTM Committee D13 on Textiles and is the direct responsibility of Subcommittee D13.58 on Yarns and Fibers.

Current edition approved July 1, 2018. Published July 2018. Originally approved in 1965T Last previous edition approved in 2012 as D2402 – 07 (2012). DOI: 10.1520/D2402-07R18.

<sup>2</sup> For referenced ASTM standards, visit the ASTM website, www.astm.org, or contact ASTM Customer Service at service@astm.org. For *Annual Book of ASTM Standards* volume information, refer to the standard's Document Summary page on the ASTM website.

3.2 For all other terminology related to textiles, refer to Terminology D123.

### 4. Summary of Test Method

4.1 A specimen is thoroughly wetted-out by immersion, centrifuged for 5 min at an acceleration of 9800 m/s<sup>2</sup> and weighed wet. Then, the wet specimen is dried and reweighed. Water retention is calculated and reported as a percentage of the dry mass.

### 5. Significance and Use

5.1 This test method for testing for water retention of fibers after centrifuging is not recommended for acceptance testing of commercial shipments because the test is more appropriate for development and research. However, if the test is to be used for acceptance testing, comparative tests as described in 5.1.1 are advised.

5.1.1 In the case of a dispute arising from differences in reported test results using Test Method D2402 for acceptance testing of commercial shipments, the purchaser and the supplier should conduct comparative tests to determine if statistical biases exist between their laboratories. As a minimum, the two parties should take a group of test specimens that are as homogeneous as possible and that are from a lot of material of the type in question. The test specimens should then be randomly assigned in equal numbers to each laboratory for testing. The average results from the two laboratories should be compared using the Student's *t*-test for unpaired data with an acceptable probability level chosen by the two parties while designing the test program. If the analysis shows a bias, its cause must be found and corrected, or the purchaser and supplier must agree to interpret future test data with consideration for the known bias.

5.2 The amount of water retained by a fiber mass increases with an increase in the hydrophilic tendency of the fiber. Thus the data obtained can be used to indicate the following:

5.2.1 Differences in water retention between the various man-made and natural fibers,

5.2.2 Degree of cross-linking in cellulosic fibers,

5.2.3 Damage incurred by wool and silk fibers due to alkaline processing, and

5.2.4 Persistence of water-repellent treatments.

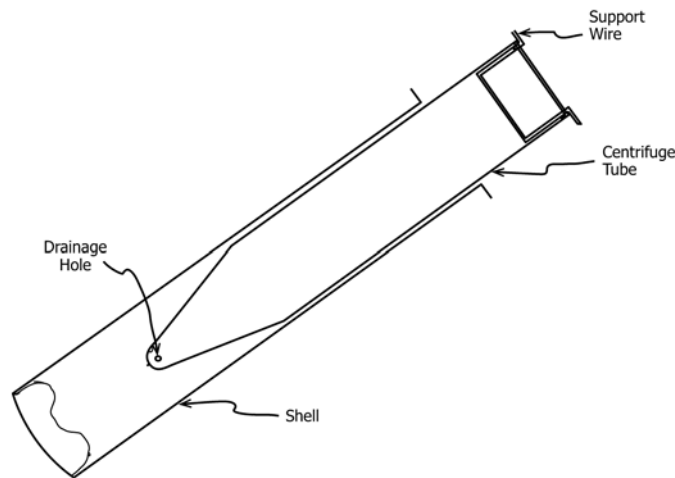

FIG. 1 Cross-section View of Centrifuge Tube Assembly

## 6. Apparatus

6.1 *Stationary Coarse Comb*<sup>3</sup>, approximately 63 mm long and having needles approximately 12.5 mm long and spaced 19 needles to the 10 mm, or

6.2 *Hand Cards*.

6.3 *Centrifuge*,<sup>4</sup> with trunnions capable of holding at least 2 tube assemblies. The centrifuge must be capable of operating to develop an angular speed that will produce a radial acceleration of 9800 m/s<sup>2</sup> (1000 g) on the specimen within 5 min.

6.4 *Tube Assemblies*, each consisting of a 15-mL, polypropylene, centrifuge tube with draining holes, shell and support wire (see Fig. 1).

6.5 *Timer*, suitable for controlling immersion time and centrifuge time to  $\pm 1$  s.

6.6 *Balance*, with sensitivity of 0.5 mg and a capacity of 2000 g.

6.7 *Weighing Containers*, air-tight, large enough to hold a specimen basket.

6.8 *Oven*, convection type, maintained at 105 to 110°C.

6.9 *Desiccator*, with an efficient desiccant such as anhydrous silica gel, anhydrous calcium sulfate, or phosphorous pentoxide.

6.10 *Bell Jar*, optional, see 10.5.1.

## 7. Hazard

7.1 Sodium hydroxide (see Note 4) is a strong base and must be handled with appropriate safety precautions. Refer to the manufacturer's material safety data sheet information.

## 8. Sampling

8.1 *Lot Sample*—As a lot sample for acceptance testing, take at random the number of shipping containers directed in the applicable material specification or other agreement between

<sup>3</sup> Combs meeting these requirements may be obtained from Alfred Suter Co., Inc., Prel Plaza, Orangeburg, NY 10962.

<sup>4</sup> A clinical safety-head centrifuge is satisfactory for this procedure.

the purchaser and supplier, such as an agreement to use Practice D3333 for staple fiber, sliver, top or tow, or to use Practice D2258/D2258M for yarn. Consider the shipping containers to be the primary sampling units.

NOTE 1—An adequate specification or other agreement between the purchaser and supplier requires taking into account the variability between shipping containers, between laboratory samples within the shipping container, and between test specimens within a laboratory sample, to provide a sampling plan with a meaningful producer's risk, consumer's risk, acceptable quality level, and limiting quality level.

8.2 *Laboratory Sample*—As a laboratory sample for acceptance testing, proceed as follows:

8.2.1 *For Staple Fiber*—Systematically take five laboratory sample subunits from each bale in the lot sample as directed in Practice D3333.

8.2.2 *For Tow and Sliver (or Top)*—From each shipping container in the lot sample, take at least a metre, or yard, of material from the leading end of the textile strand that has a clean uniform appearance. If the shipping container has multiple packages, take one package drawn at random from the container for that laboratory sample.

8.2.3 *For Yarn in Cases*—Take ten yarn packages as directed in Practice D2258/D2258M. Remove enough traverses of yarn to obtain a surface free of visible damage or soil, and then remove at least a gram of yarn for the laboratory sample from each laboratory sampling unit.

8.2.4 *For Yarn on Beams*—Sample as agreed upon between the purchaser and supplier.

8.3 *Test Specimens*—Test two 0.5 g specimens from each laboratory sampling unit, preferably from different sections of the laboratory sample units.

## 9. Conditioning

9.1 Specimens may be tested without any conditioning.

## 10. Specimen Preparation

10.1 *Foreign Matter and Extractable Matter*—If the laboratory sample units contain foreign matter, remove the latter by mechanical means (such as hand carding). For samples containing nonfibrous natural constituents of the fiber (such as oils