



Designation: D1478 – 18

Standard Test Method for Low-Temperature Torque of Ball Bearing Grease¹

This standard is issued under the fixed designation D1478; the number immediately following the designation indicates the year of original adoption or, in the case of revision, the year of last revision. A number in parentheses indicates the year of last reapproval. A superscript epsilon (ϵ) indicates an editorial change since the last revision or reapproval.

This standard has been approved for use by agencies of the U.S. Department of Defense.

1. Scope*

1.1 This test method covers the determination of the extent to which a grease retards the rotation of a slow-speed ball bearing by measuring starting and running torques at low temperatures (below $-18\text{ }^{\circ}\text{C}$ ($0\text{ }^{\circ}\text{F}$)).

1.1.1 Torque measurements are limited by the capacity of the torque-measuring equipment.

1.1.2 This test method is not suitable for greases exhibiting torque values greater than 50 000 g-cm at the selected test temperature.

NOTE 1—When initially developed, the original dynamometer scale limited the torque capacity to approximately 30 000 g-cm; the original dynamometer scale is obsolete, however. The suggested replacement scale has not been evaluated; it could extend the limit to approximately 50 000 g-cm.

1.2 The values stated in SI units are to be regarded as standard.

1.2.1 *Exceptions*—The values given in parentheses are for information only. The exception is torque values that are given in cgs-metric units, which are widely used in grease specifications.

1.3 *This standard does not purport to address all of the safety concerns, if any, associated with its use. It is the responsibility of the user of this standard to establish appropriate safety, health, and environmental practices and determine the applicability of regulatory limitations prior to use.* For specific hazard and warning statements, see 6.1.1, 7.2, 7.4, 8.7, and 8.11.

1.4 *This international standard was developed in accordance with internationally recognized principles on standardization established in the Decision on Principles for the Development of International Standards, Guides and Recommendations issued by the World Trade Organization Technical Barriers to Trade (TBT) Committee.*

¹ This test method is under the jurisdiction of ASTM Committee D02 on Petroleum Products, Liquid Fuels, and Lubricants and is the direct responsibility of Subcommittee D02.G0.05 on Functional Tests - Temperature.

Current edition approved June 1, 2018. Published July 2018. Originally approved in 1957. Last previous edition approved in 2017 as D1478 – 11 (2017) ^{ϵ 1}. DOI: 10.1520/D1478-18.

2. Referenced Documents

2.1 *ASTM Standards*:²

D4693 Test Method for Low-Temperature Torque of Grease-Lubricated Wheel Bearings

2.2 *ANSI/ABMA Standard*:

ABMA 20:2011 Radial Bearings of Ball, Cylindrical, Roller, and Spherical Roller Type—Metric Designs (ABMA Code 20BCO2JO)³

3. Terminology

3.1 *Definitions of Terms Specific to This Standard*:

3.1.1 *low-temperature torque, n*—the torque in g-cm required to restrain the outer ring of a No. 6204 size open ball bearing lubricated with the test grease while the inner ring is rotated at $1\text{ r/min} \pm 0.05\text{ r/min}$ at the test temperature.

3.1.2 *running torque, n*—the 15 s average value of the torque after rotation for a specified period of time (60 min).

3.1.3 *starting torque, n*—the maximum torque measured at the start of rotation.

4. Summary of Test Method

4.1 A No. 6204 open ball bearing is packed completely full of the test grease and cleaned off flush with the sides. The bearing remains stationary while ambient temperature is lowered to the test temperature and held there for 2 h. At the end of this time, the inner ring of the ball bearing is rotated at $1\text{ r/min} \pm 0.05\text{ r/min}$ while the restraining force on the outer ring is measured.

4.2 Torque is determined by multiplying the restraining force by the radius of the bearing housing. Both starting torque and torque after 60 min of rotation (running torque) are determined.

² For referenced ASTM standards, visit the ASTM website, www.astm.org, or contact ASTM Customer Service at service@astm.org. For *Annual Book of ASTM Standards* volume information, refer to the standard's Document Summary page on the ASTM website.

³ Available from ABMA (American Bearing Manufacturers Association), 330 N. Wabash Ave., Ste. 2000, Chicago, IL 60611.

*A Summary of Changes section appears at the end of this standard

5. Significance and Use

5.1 This test method was developed using greases having very low torque characteristics at $-54\text{ }^{\circ}\text{C}$ ($-65\text{ }^{\circ}\text{F}$). Specifications for greases of this type commonly require testing at this temperature. Specifications for greases of other types can require testing at temperatures from $-73\text{ }^{\circ}\text{C}$ to $-18\text{ }^{\circ}\text{C}$ ($-100\text{ }^{\circ}\text{F}$ to $0\text{ }^{\circ}\text{F}$).

5.2 This test method has proved helpful in the selection of greases for low-powered mechanisms, such as instrument bearings used in aerospace applications. The suitability of this test method for other applications requiring different greases, speeds, and temperatures should be determined on an individual basis.

5.3 Test Method D4693 may be better suited for applications using larger bearings or greater loads. However, greases having such characteristics that permit torque evaluations by either this test method or Test Method D4693 will not give the same values in the two test methods (even when converted to the same torque units) because the apparatus and test bearings are different.

6. Apparatus

6.1 Fig. 1 shows a suitable torque test apparatus assembly. It consists of the components described in 6.1.1 – 6.1.5.

6.1.1 *Low-Temperature Box*—Any well-insulated box of at least 0.03 m^3 (1 ft^3) interior volume, in which the air temperature can be controlled and maintained within $0.5\text{ }^{\circ}\text{C}$ ($1\text{ }^{\circ}\text{F}$) of the test temperature. (**Warning**—Direct impact on the test bearing by an air stream colder than the test temperature must be avoided to preclude erroneous results. Baffles should be used where necessary to prevent such direct impact. The drive mechanism can be mounted externally as shown in Fig. 2, or the entire drive mechanism can be inserted directly into the box. When the drive is mounted externally, the temperature measured at a point on the surface of the test shaft between the test bearing and wall of the box shall be not more than $0.5\text{ }^{\circ}\text{C}$ ($1\text{ }^{\circ}\text{F}$) above the test temperature.)

6.1.2 *Drive Assembly*, as shown in Fig. 2, including drive motor, gear reductor, and test shaft. The test shaft shall receive the test bearing against a shoulder having a diameter smaller

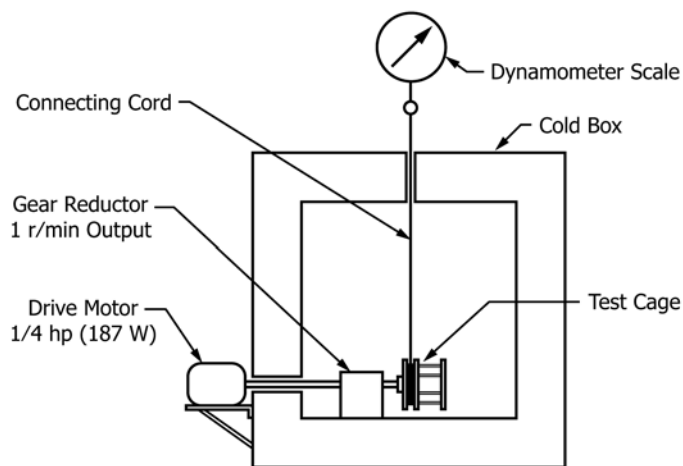

FIG. 1 Torque Test Apparatus Assembly

than the inner race shoulder of the bearing. Use a spacer washer of the same diameter and at least 1.6 mm ($1/16\text{ in.}$) thick, along with a test bearing lock nut, to clamp the inner ring of the test bearing to the 1 r/min shaft.

6.1.3 *Housing (Cage)*—Bearing housing, load disk, load ring, clamp rod, and associated parts made in accordance with Fig. 3. Adjust the mass of Part 2A (load disk) to be $454\text{ g} \pm 3\text{ g}$ (1 lb). Alternatively, if Part 2B (load ring) is used, adjust the mass of Part 2B to be $454\text{ g} \pm 3\text{ g}$ (1 lb).

6.1.4 *Torque-Measuring Equipment*—A calibrated dynamometer scale⁴ having a range of approximately 0 kg to 10 kg , 0 N to 100 N , or 0 lb to 25 lb , with a large face diameter (approximately 200 mm (8 in.), or larger) and a suitable connecting cord of sufficient length (for example, a braided metallic cable fitted with a ring or loop on each end, or a 15 kg (35 lb) nylon fishing line, or test string saturated with silicone oil).

NOTE 2—Substitution of other suitable torque-measuring equipment, such as a strain-gage load cell, is permitted.

6.1.5 *Spindle and Grease Cup*, as shown in Fig. 4 and Fig. 5, respectively.

7. Materials

7.1 *Test Bearing*—No. 6204 size open ball bearing (ABMA 20:2011, ABMA Code 20BCO2JO) containing eight 7.9 mm ($5/16\text{ in.}$) balls, separated by a two-piece, pressed steel cage, and manufactured to ABEC-3 (Annular Bearing Engineering Committee) tolerances with the standard radial clearance of 0.021 mm to 0.028 mm (0.0008 in. to 0.0011 in.).⁵

7.2 *Mineral Spirits, Reagent Grade*. (**Warning**—Combustible. Health Hazard.)

7.3 *Purity of Reagents*—Reagent grade chemicals shall be used in all tests. Unless otherwise indicated, it is intended that all reagents shall conform to the specifications of the committee on Analytical Reagents of the American Chemical Society, where such specifications are available.⁶

7.4 *n-Heptane*, reagent grade minimum purity. (**Warning**—Flammable. Health Hazard.)

8. Procedure

8.1 Wash the selected test bearing thoroughly in mineral spirits and rinse it in a beaker of *n*-heptane. Dry the bearing for

⁴ The sole source of supply of the Dynamometer Scale, QDS-25 previously known to the committee was R. Chatillon & Sons Inc., 83-28 Kew Gardens Rd., Kew Gardens, NY 11415. However, it is understood that over time, this Dynamometer Scale became obsolete, and it is no longer commercially available. If you are aware of potential alternative suppliers, please provide this information to ASTM International Headquarters. Your comments will receive careful consideration at a meeting of the responsible technical committee,¹ which you may attend.

⁵ Supporting data (copies of correspondence and test data regarding the selection of the test bearing) have been filed at ASTM International Headquarters and may be obtained by requesting Research Report RR:D02-1272. Contact ASTM Customer Service at service@astm.org.

⁶ *Reagent Chemicals, American Chemical Society Specifications*, American Chemical Society, Washington, DC. For Suggestions on the testing of reagents not listed by the American Chemical Society, see *Annual Standards for Laboratory Chemicals*, BDH Ltd., Poole, Dorset, U.K., and the *United States Pharmacopeia and National Formulary*, U.S. Pharmacopeial Convention, Inc. (USPC), Rockville, MD.

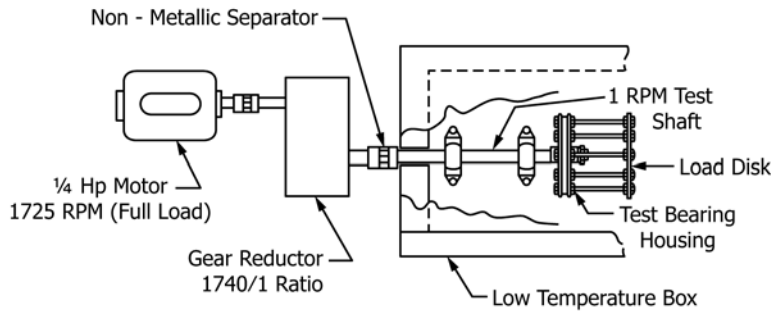

FIG. 2 Drive (Top View)

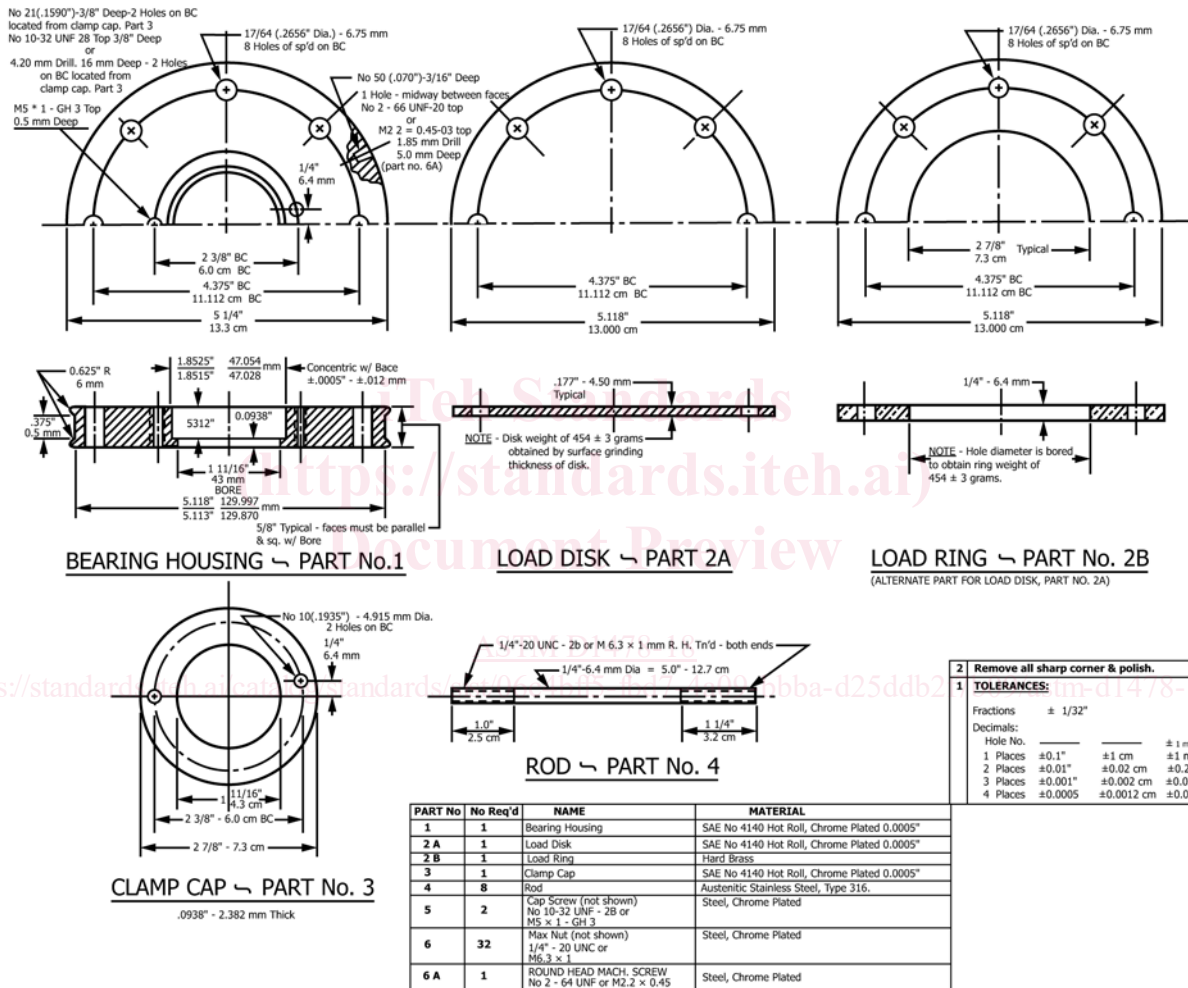

FIG. 3 Cage Parts

approximately 20 min in a warm oven (not over 100 °C (212 °F)). Permit the bearing to cool to room temperature before proceeding.

8.2 Lubricate the bearing with five drops of oil having a viscosity of 28 cSt to 32 cSt at 100 °C (135 SUS to 150 SUS at 210 °F). The bearing shall then show no roughness or catching when rotated between the fingers while applying light pressure axially and then radially. Use the dynamometer to determine the running torque at room temperature; note the average and maximum running torque peaks. The average shall not exceed

20 g·cm (2.0 mN·m), and no peak shall exceed 25 g·cm (2.5 mN·m). If torque values fall below these limits, the bearing is suitable for the grease torque test. If torque values exceed these limits, the bearing should be recleaned and retested or discarded.

8.3 Clean and dry a bearing that has been determined to be acceptable (8.2). Mount the bearing on a hand spindle (Fig. 4), fastening the inner race by means of the washer and screw. Fill

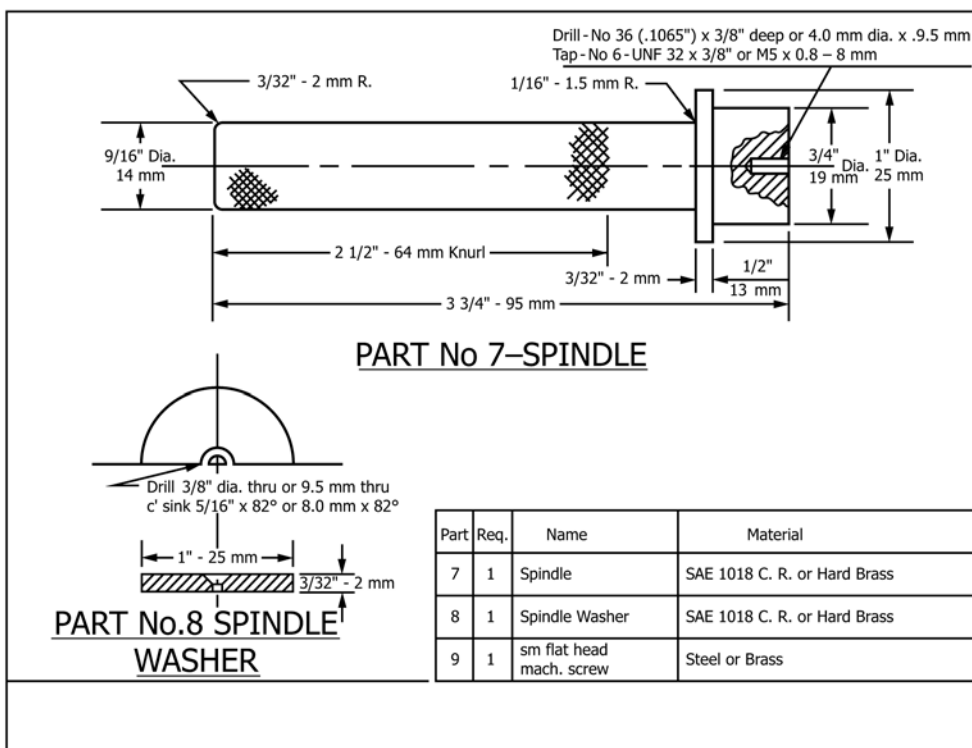

FIG. 4 Spindle

the grease cup (Fig. 5) at least three-fourths full of the test grease, using a clean steel spatula. Minimize the inclusion of air.

8.4 Force the bearing down into the grease and rotate the spindle-bearing assembly slowly, first in one direction and then the other, to ensure that grease is worked into all parts of the bearing. When the bearing bottoms in the cup, slide the cylindrical cup ring off the plate and remove the spindle-bearing assembly from the cup. (The assembly may be pushed or pulled through the cup.)

8.5 Remove the bearing from the spindle. Turn the bearing end-for-end, and refasten it on the spindle.

8.6 Repack excess grease into the assembled grease cup. Again, force the bearing down into the grease, while rotating the spindle-bearing assembly slowly, first in one direction and then the other, until the bearing bottoms.

8.7 Slide the cup ring off of the plate, and remove the spindle-bearing assembly from the cup ring. Scrape the excess grease off flush with the sides of the bearing, filling any visible voids, and then remove the spindle. (**Warning**—Take care not to rotate the bearing at any time after striking the grease flush and prior to the measurement of starting torque.)

8.8 Insert the packed bearing into the test housing and fasten the clamp cap over the bearing.

8.9 With the low-temperature box precooled to the test temperature, open the box and slide the test bearing and housing over the end of the test shaft. Fasten it with the washer and nut tightly enough to prevent slippage.

8.10 Attach the cord under the head of the screw on the periphery of the housing. Rotate the test shaft until the slack in the cord hanging from the hook on the dynamometer scale above is almost taken up. The screw on the periphery must then be at least 90 degrees down from vertical. More than 90 degrees is acceptable, provided that the cord does not slip off the periphery of the housing (Fig. 1).

NOTE 3—Measurements can also be made from horizontal or other positions if the cord attaching point is at or beyond the point of tangency of the cord while torque is being measured. This will ensure a full 65 mm (2.56 in.) torque radius.

8.11 Close the box, and recool it to the test temperature. Maintain this temperature within $\pm 0.5^\circ\text{C}$ (1°F) for 2 h after the box has recovered to the test temperature. (**Warning**—During this time the bearing must not be disturbed or the test will be invalid.)

8.11.1 It is desirable that excessive condensation of moisture from the air in the cold box be prevented, especially during humid weather. To this end and prior to the test, place shallow trays containing a desiccant in the bottom of the low temperature box.

8.12 Check the torque cord to be sure it is free of ice and not stuck to the box. A split rubber stopper can be used to close the hole in the box wall, through which the cord runs, to keep the cord and passage free of ice from moisture-laden air. Remove the stopper before the run.

8.13 To determine starting torque, start the drive motor and observe the dynamometer scale. Record the maximum reading and calculate the starting torque according to Section 9.