



Designation: C1651 – 11 (Reapproved 2018)

Standard Test Method for Measurement of Roll Wave Optical Distortion in Heat-Treated Flat Glass¹

This standard is issued under the fixed designation C1651; the number immediately following the designation indicates the year of original adoption or, in the case of revision, the year of last revision. A number in parentheses indicates the year of last reapproval. A superscript epsilon (ϵ) indicates an editorial change since the last revision or reapproval.

1. Scope

1.1 This test method is applicable to the determination of the peak-to-valley depth and peak-to-peak distances of the out-of-plane deformation referred to as roll wave which occurs in flat, heat-treated architectural glass substrates processed in a heat processing continuous or oscillating conveyance oven.

1.2 This test method does not address other flatness issues like edge kink, ream, pocket distortion, bow, or other distortions outside of roll wave as defined in this test method.

1.3 The values stated in inch-pound units are to be regarded as standard. The values given in parentheses are mathematical conversions to SI units that are provided for information only and are not considered standard.

1.4 *This standard does not purport to address all of the safety concerns, if any, associated with its use. It is the responsibility of the user of this standard to establish appropriate safety, health, and environmental practices and determine the applicability of regulatory limitations prior to use.*

1.5 *This international standard was developed in accordance with internationally recognized principles on standardization established in the Decision on Principles for the Development of International Standards, Guides and Recommendations issued by the World Trade Organization Technical Barriers to Trade (TBT) Committee.*

2. Referenced Documents

2.1 Reference to these documents shall be the latest issue unless otherwise specified by the authority applying this test method.

2.2 *ASTM Standards:*²

C162 [Terminology of Glass and Glass Products](#)

¹ This test method is under the jurisdiction of ASTM Committee C14 on Glass and Glass Products and is the direct responsibility of Subcommittee C14.11 on Optical Properties.

Current edition approved Aug. 1, 2018. Published August 2018. Originally approved in 2008. Last previous edition approved in 2011 as C1651 – 11. DOI: 10.1520/C1651-11R18.

² For referenced ASTM standards, visit the ASTM website, www.astm.org, or contact ASTM Customer Service at service@astm.org. For *Annual Book of ASTM Standards* volume information, refer to the standard's Document Summary page on the ASTM website.

[C1036 Specification for Flat Glass](#)

[C1048 Specification for Heat-Strengthened and Fully Tempered Flat Glass](#)

3. Terminology

3.1 *Definitions of Terms Specific to This Standard:*

3.1.1 *peak-to-valley depth of roll wave*—characteristic depth, W , of roll wave as illustrated in [Fig. 1](#).

3.1.2 *peak-to-peak wavelength of roll wave*—characteristic length, L , of roll wave shown as a sine-wave representing the deformed surface section as illustrated in [Fig. 1](#).

3.1.3 *roll wave*—A repetitive wave-like departure from flatness in glass that results from heat treating the glass in a horizontal roller hearth furnace. Roll wave excludes edge effects such as edge kink and distortion influenced by assembly or installation.

3.1.4 *roll wave optical distortion*—visual distortion, D , that results from roll wave and expressed as lens power as in Eq 1.

3.1.5 *valley-to-valley wavelength of roll wave*—characteristic length, L , of roll wave shown as a sine-wave representing the deformed surface section as illustrated in [Fig. 1](#).

4. Summary of Test Method

4.1 This test consists of moving an instrument across the glass surface in a direction parallel to the direction that the glass substrate traveled during heat processing. The instrument will primarily measure the out-of-plane deformation of the glass surface which is characteristic of the glass and known as “roll wave”. The peak-to-valley depths of the roll waves, W , and the peak-to-peak distances, L , are measured. (See [Fig. 1](#).)

4.1.1 Other out-of-plane deformations of the glass surface may also be present which do not have the same peak and valley wave character of the roll wave, but which also result in the appearance of optical distortion in the glass.

4.1.2 The optical distortion due to the out-of-plane deformation of the surface is measured as an optical power, similar to the optical power of a cylindrical mirror or lens.

4.1.3 For those deformations that do have a wave character, the distortion can be calculated using the following formula. From the measured roll wave depth, W and the measured

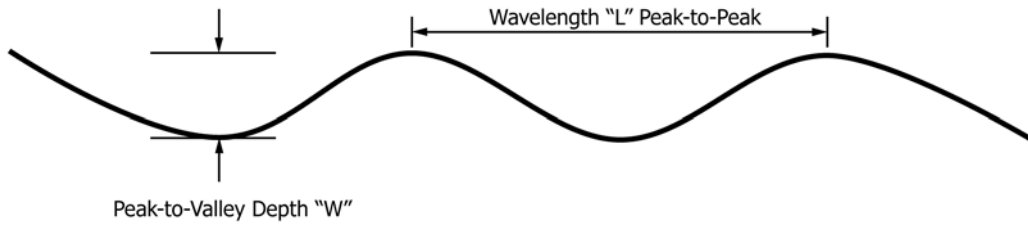

FIG. 1 Representative Roll Wave Showing "W" and "L"

peak-to-peak or valley to valley wavelength of the roll wave, L , the optical roll wave distortion D is:

$$D = 4\pi^2 W/L^2 \quad (1)$$

where W and L are in metres and D is in diopters. The dimensions of diopters (dpt) is m^{-1} . The more usual unit of optical distortion is millidiopters which are obtained by multiplying the value in diopters by 1000.

4.2 Appendix X1 and references show the relationship between W , L , the measured radius of curvature R and the optical distortion of a reflecting surface, D .

5. Significance and Use

5.1 This test method is a procedure for determining the peak-to-valley depth and the wavelength of roll wave in flat glass and then calculating the optical distortion resulting from that roll wave. Peak-to-valley measurements provide a means of monitoring the roll wave distortion in a heat processed glass product.

5.2 Measured peak-to-valley depth provides information required by some specifiers of heat-treated glass products.

5.3 Roll wave is inherent in flat glass which has been heat treated in a furnace in which rollers are used to convey the glass.

5.4 Consult Specifications C1036 and C1048 for additional glass characteristics and quality information.

6. Apparatus

6.1 Optical distortion in flat glass can be characterized by determining the out-of-plane deformation of the glass by use of an instrument to measure the peak-to-valley depth of the deformations. Two such instruments are the so-called "Flat Bottom" Gauge and the "Three Point Contact" Gauge. (As stated in 10.1 a Round Robin Interlaboratory Study (ILS) will be carried out to establish, among other things, the comparative precision and bias of measurement made with the "Flat Bottom" Gauge and the "Three Point Contact" Gauge.)

6.2 The "Flat Bottom" Gauge consists of a flat plate which is a minimum of 12 in. (305 mm) long. (The flat plate shall be equal to or greater in length than the circumference of the furnace roller and less than twice the circumference of the roller.) It shall be no less than 2 in. (50.8 mm) wide, with a smooth, low-coefficient of friction surface and have a depth measuring gauge equipped with a dial indicator, digital micrometre, or linear variable differential transformer (LVDT) with a protruding ball-end spring loaded plunger. This indicator, micrometre, or LVDT is used to measure the out-of-plane depth, W , of valleys and is located at the center of the bar. Such a gauge is shown in Fig. 2.

6.3 The "Three Point Contact" Gauge has three contact points, one at each end of the gauge and equally spaced from a center contact point at which position the depth of the roll wave is measured. The distance between the outboard contact

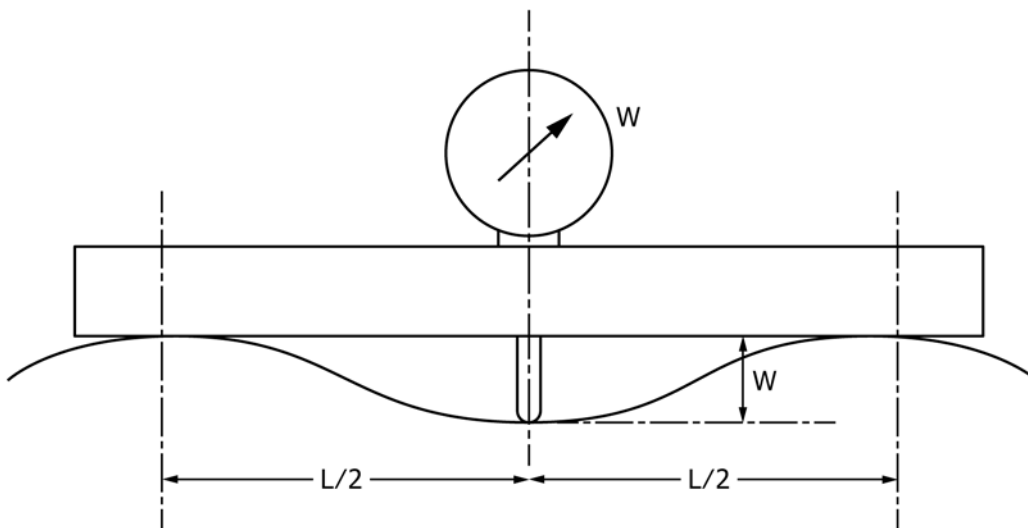

FIG. 2 "Flat Bottom" Roll Wave Gauge with Dial Indicator

points of the “Three Point Contact” Gauge must be adjustable to permit setting the outside contact points apart by a distance equal to the wavelength, L , of the roll wave. The center contact point is a depth measuring gauge which can be either a dial indicator, a digital micrometre, or a spring loaded LVDT plunger. Such a gauge is shown in Fig. 3 and Fig. 4.

NOTE 1—The wavelength of the roll wave is often, but not always equal to the circumference of the conveyor rolls in the tempering furnace.

NOTE 2—Surface distortions apart from roll wave are likely present and should not be considered when calculating the average wavelength (L_{ave}) in 8.1. These invalid wavelengths include: (1) any peak-to-peak or valley-to-valley distance that is not within ± 1 in. (± 25.4 mm) of roll circumference (if known), or (2) any peak or valley measurement that does not repeat at equal intervals.

NOTE 3—If the measured roll wave wavelength is not within ± 1 in. (± 25.4 mm) of roll circumference, or when the circumference of the furnace roll is not known, the Flat Bottom Gauge should be used to measure roll wave since its use does not depend on knowing the average wavelength of the roll wave.

6.4 These instruments can be manually conveyed across the glass or fitted with a trolley system for pulling it across the glass and plotting depth, W , versus position as described in the literature. (1, 2, 3)³

6.5 The glass to be measured shall be placed on a flat supporting surface with any edge/end kink facing upward. The direction of the edge/end kink may be determined by using visual or optical inspection techniques (such as the reflection of a Zebra board) or production documentation, or both. The supporting surface should have dimensions equal to or exceeding the dimensions the specimen to be tested. The departure from flatness of the supporting surface shall be less than the depth of the out-of-plane roll wave deformations if the measurement is to be accurate. The table or surface must be free of debris and any other surface condition that might affect the reading.

³ The boldface numbers in parentheses refer to a list of references at the end of this standard.

6.6 This test method is appropriate principally for in-plant or laboratory measurement of roll wave distortion. The test method can be adapted to on-site measurements of roll wave only after removal of the glass from its frame and supporting it in accordance with 6.5. This would automatically exclude insulating glass units and laminated glass lites from measurement under this test method.

7. Procedure

7.1 Place the clean test lite on a flat supporting surface in accordance with 6.5.

7.1.1 Prior to using the roll wave gauge for measurement, place it on a rigid flat surface, such as a granite plate, or on a piece of annealed float glass which is greater than or equal to $\frac{3}{8}$ in. (10 mm) in thickness and which is larger than the gauge. The depth of measuring plunger must be depressed by some amount when the gauge is resting on the flat surface. Adjust the gauge meter to read zero, following the gauge manufacturer’s instructions.

7.1.2 Determine the direction of the roll waves using visual or optical inspection (such as the reflection of a Zebra board) or production documentation, or both. Place a measuring tape on the glass surface perpendicular to the roll waves. The measuring tape shall extend from leading or trailing edge and extend the entire length of the substrate where the roll wave peaks and valleys will be determined.

7.2 Procedure A: Measuring with a Flat Bottom Gauge:

7.2.1 Place the gauge on the surface of the glass as shown in Fig. 2 at the approximate centerline of the glass dimension perpendicular to the roll wave and near one end of the expected scan. To eliminate the influence of the end-effects on the computation of Optical Distortion, the first peak or valley used for computation of optical distortion shall be no less than 12 in. (305 mm), or one wavelength, whichever is larger, from the edge of the glass.

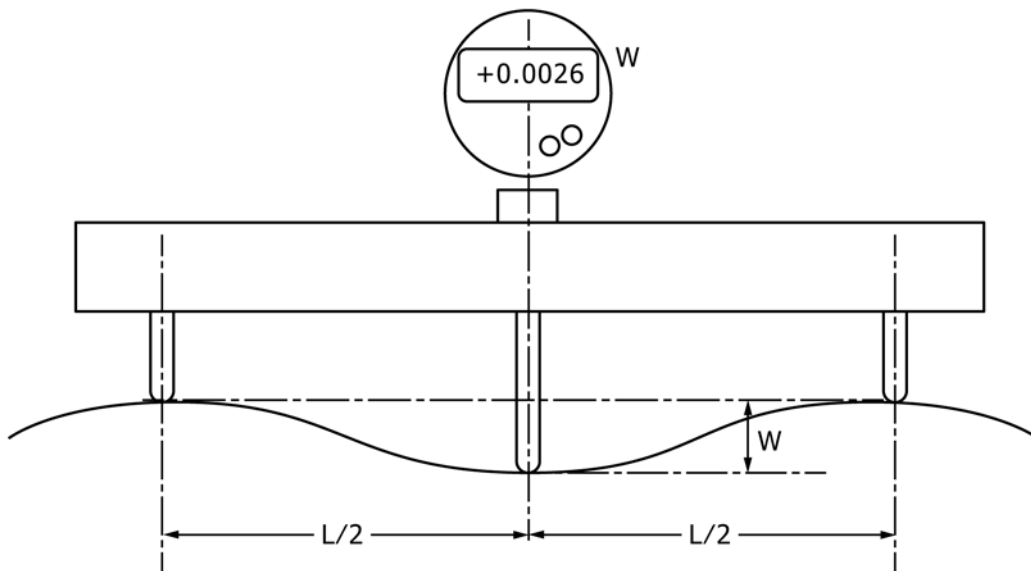

FIG. 3 “Three-Point Contact” Gauge on Valley