



Designation: **C497 – 18a C497 – 18b**

Standard Test Methods for Concrete Pipe, Manhole Sections, or Tile¹

This standard is issued under the fixed designation C497; the number immediately following the designation indicates the year of original adoption or, in the case of revision, the year of last revision. A number in parentheses indicates the year of last reappraisal. A superscript epsilon (ϵ) indicates an editorial change since the last revision or reappraisal.

This standard has been approved for use by agencies of the U.S. Department of Defense.

1. Scope

1.1 These test methods cover testing of concrete pipe, manhole sections, and tile. The test methods described are used in production testing and acceptance testing to evaluate the properties provided for in the specifications.

1.2 The test methods appear in the following order:

	Section
External Load Crushing Strength	4
Flat Slab Top	5
Gore Strength	6
<u>Core Strength</u>	<u>7</u>
Absorption	7
<u>Absorption</u>	<u>8</u>
Hydrostatic	8
<u>Hydrostatic</u>	<u>9</u>
Permeability	9
<u>Permeability</u>	<u>10</u>
Manhole Step	10
<u>Manhole Step</u>	<u>11</u>
Cylinder Strength	11
<u>Cylinder Strength</u>	<u>12</u>
Gasket Lubricant	12
<u>Gasket Lubricant</u>	<u>13</u>
Joint Shear	13
<u>Joint Shear</u>	<u>14</u>
Alkalinity	14
<u>Alkalinity</u>	<u>15</u>
Gasket Measurements	15
<u>Gasket Measurements</u>	<u>16</u>
Off-Center Hydrostatic Joint Test	16
<u>Off-Center Hydrostatic Joint Test</u>	<u>17</u>
Hydrostatic External Joint Test Method	17
<u>Hydrostatic External Joint Test Method</u>	<u>18</u>
Welded Splice Pull Test	18
<u>Welded Splice Pull Test</u>	<u>19</u>

1.3 The test specimens shall not have been exposed to a temperature below 40°F for the 24 h immediately preceding the test.

1.4 If any test specimen fails because of mechanical reasons such as failure of testing equipment or improper specimen preparation, it shall be discarded and another specimen taken.

1.5 Specimens shall be selected in accordance with the specifications for the type of pipe or tile being tested.

1.6 A complete metric companion to Test Methods C497 has been developed—C497M; therefore, no metric equivalents are presented in these methods.

1.7 *This standard does not purport to address all of the safety concerns, if any, associated with its use. It is the responsibility of the user of this standard to establish appropriate safety, health, and environmental practices and determine the applicability of regulatory limitations prior to use.*

1.8 *This international standard was developed in accordance with internationally recognized principles on standardization established in the Decision on Principles for the Development of International Standards, Guides and Recommendations issued by the World Trade Organization Technical Barriers to Trade (TBT) Committee.*

¹ These test methods are under the jurisdiction of ASTM Committee C13 on Concrete Pipe and are the direct responsibility of Subcommittee C13.09 on Methods of Test. Current edition approved May 1, 2018 June 1, 2018. Published May 2018 August 2018. Originally approved in 1962. Last previous edition approved in 2018 as C497 – 18; C497 – 18a. DOI: 10.1520/C0497-18A; 10.1520/C0497-18B.

2. Referenced Documents

2.1 ASTM Standards:²

C31/C31M Practice for Making and Curing Concrete Test Specimens in the Field

C39/C39M Test Method for Compressive Strength of Cylindrical Concrete Specimens

C42/C42M Test Method for Obtaining and Testing Drilled Cores and Sawed Beams of Concrete

C617 Practice for Capping Cylindrical Concrete Specimens

C670 Practice for Preparing Precision and Bias Statements for Test Methods for Construction Materials

C822 Terminology Relating to Concrete Pipe and Related Products

C1231/C1231M Practice for Use of Unbonded Caps in Determination of Compressive Strength of Hardened Cylindrical Concrete Specimens

D2240 Test Method for Rubber Property—Durometer Hardness

E4 Practices for Force Verification of Testing Machines

3. Terminology

3.1 *Definitions*—For definitions of terms relating to concrete pipe, see Terminology C822.

4. External Load Crushing Strength Test by the Three-Edge Bearing Test Method

4.1 *Summary of Test Method*—The test specimen is tested in a machine designed to apply a crushing force upon the specimen in a plane through the vertical axis extending along the length of the specimen.

4.2 *Significance and Use*—The crushing test shall be either a quality control test performed to establish that the finished, shippable pipe has sufficient strength to withstand the crushing loads stated in the specifications or a proof of design test performed to prove the adequacy of design.

4.3 Apparatus:

4.3.1 The testing machine shall be of any type of sufficient capacity and shall be capable of providing the rate of loading prescribed in 4.5.3.

4.3.2 The testing machine shall be substantial and rigid throughout, so that the distribution of the load will not be affected appreciably by the deformation or yielding of any part.

4.3.3 The three-edge-bearing method of loading shall be used. The test specimen shall be supported on a lower bearing of two parallel longitudinal strips and the load applied through an upper bearing (Figs. 1-4). At the option of the manufacturer, either or both the lower bearing and the upper bearing shall extend the full length or any portion of the length of the specimen. Fig. 5

4.3.4 The lower bearings shall consist of wood or hard rubber strips. Wooden strips shall be straight, have a cross section of not less than 2 in. in width and not less than 1 in. nor more than 1½ in. in height and shall have the top inside corners rounded to a radius of ½ in. Hard rubber strips shall have a durometer hardness of not less than 45 nor more than 60. They shall be rectangular in cross section, having a width of not less than 2 in., a thickness of not less than 1 in. nor more than 1½ in., and shall have the top inside corner rounded to a radius of ½ in.

4.3.5 The lower bearing strips shall be fastened to a wooden or steel beam or directly to a concrete base, any of which shall provide sufficient rigidity so that deflection is not greater than 1/720 of the specimen length when the maximum load is applied. The rigid base shall be at least 6 in. wide. The interior vertical sides of the strips shall be parallel and spaced a distance apart of not more than 1 in./ft of specimen diameter, but in no case less than 1 in. The bearing faces of the lower strips shall not vary from a straight line vertically or horizontally by more than 1/32 in./ft of length under no load.

4.3.6 The upper bearing shall be a rigid wood beam with or without an attached hard rubber strip. The wood shall be sound, free of knots, and straight and true from end to end. It shall be fastened to a steel or wood-faced steel beam of such dimensions that deflections under maximum load will not be greater than 1/720 of the specimen length. The bearing face of the upper bearing shall not deviate from a straight line by more than 1/32 in./ft of length. When a hard rubber strip is used on the bearing face it shall have a durometer hardness of not less than 45 nor more than 60, and shall have a width of not less than 2 in. and a thickness of not less than 1 in. nor more than 1½ in. and shall be secured to a wood beam meeting the above requirements.

4.3.7 If mutually agreed upon by the manufacturer and the owner prior to the test, before the specimen is placed, a fillet of plaster of paris not exceeding 1 in. in thickness shall be cast on the surface of the upper and lower bearings. The width of the fillet cap, upper or lower, shall be not more than 1 in./ft of the specimen diameter, but in no case less than 1 in.

4.3.8 The equipment shall be so designed that the load will be distributed about the center of the overall length (L_1) of the specimen (Figs. 1-4). At the option of the manufacturer, the center of the load shall be applied at any point of the overall length (L_1) of the specimen. The load shall be applied either at a single point or at multiple points dependent on the length of the specimen being tested and the rigidity of the test frame.

² For referenced ASTM standards, visit the ASTM website, www.astm.org, or contact ASTM Customer Service at service@astm.org. For *Annual Book of ASTM Standards* volume information, refer to the standard's Document Summary page on the ASTM website.

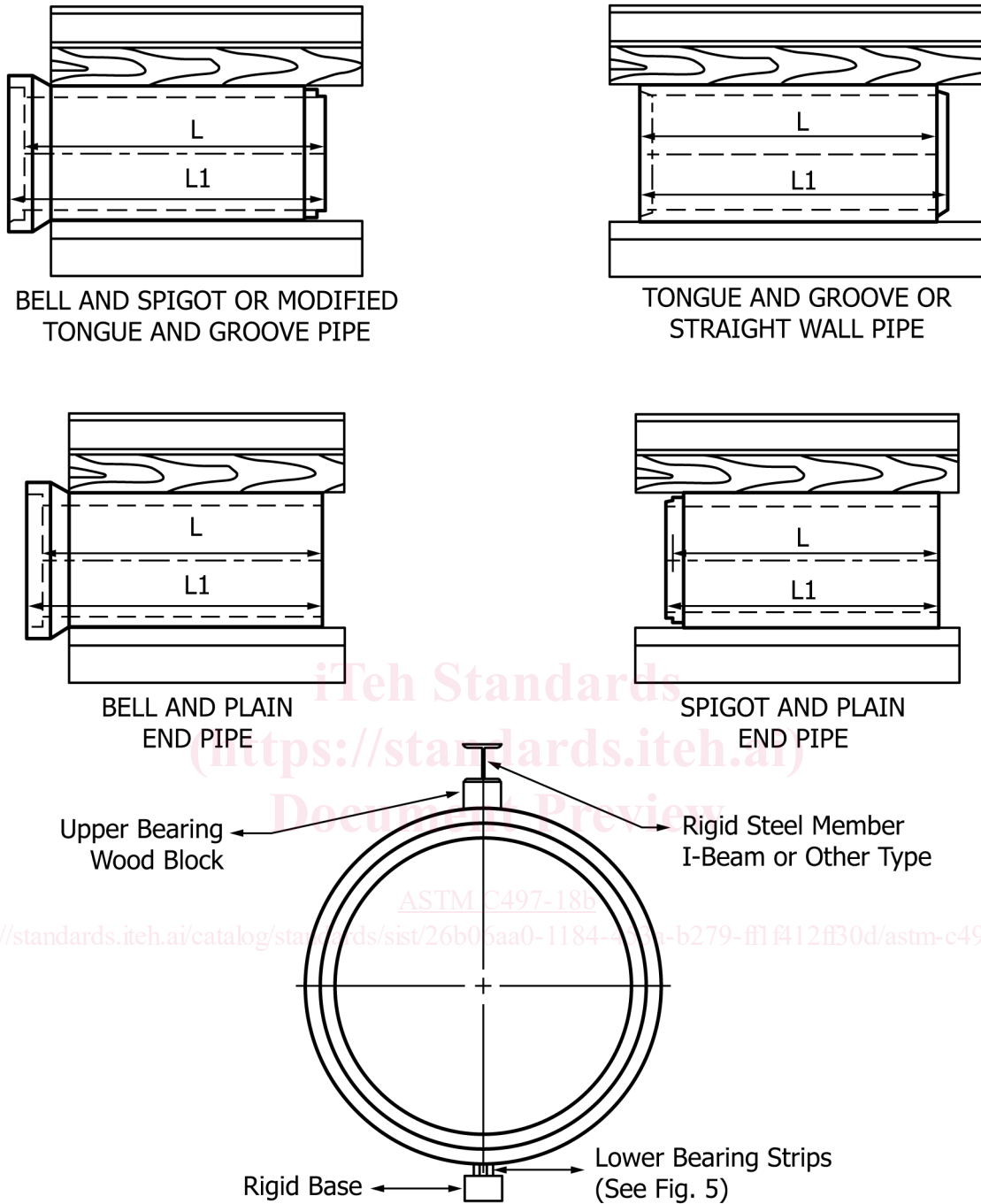

NOTE 1—The figures illustrate a method of applying the load to the pipe.

FIG. 1 Three-Edge-Bearing Test, Circular Pipe

NOTE 1—The user of these test methods is advised that multiple points of load applications to the upper bearing will permit use of lighter beams without excessive deflection.

4.4 *Calibration*—The loading device shall be one which shall provide an accuracy of $\pm 2\%$ at the specified test loads. A calibration curve shall be used. The machines used for performing the three-edge-bearing tests shall be verified in accordance with Practices E4.

4.5 *Procedure:*

4.5.1 Place the specimen on the two lower bearing strips in such a manner that the pipe or tile rests firmly and with uniform bearing on each strip.

4.5.2 Mark the two ends of the specimen at a point midway between the lower bearing strips and then establish the diametrically opposite point on each end. Place the upper bearing so that it is aligned with these marks.

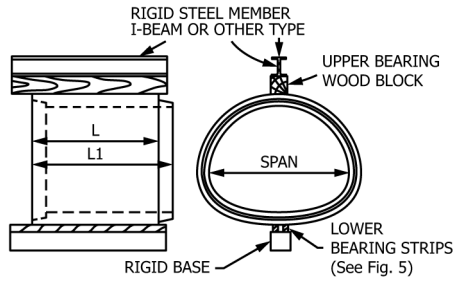

NOTE 1—The figure illustrates a method of applying the load to the pipe.
FIG. 2 Three-Edge-Bearing Test, Arch Pipe

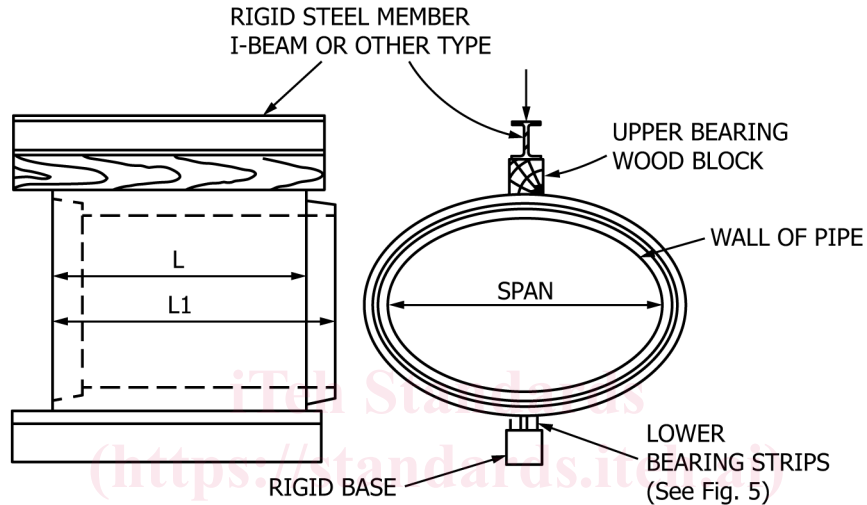

NOTE 1—The figure illustrates a method of applying the load to the pipe.
FIG. 3 Three-Edge-Bearing Test, Horizontal Elliptical Pipe

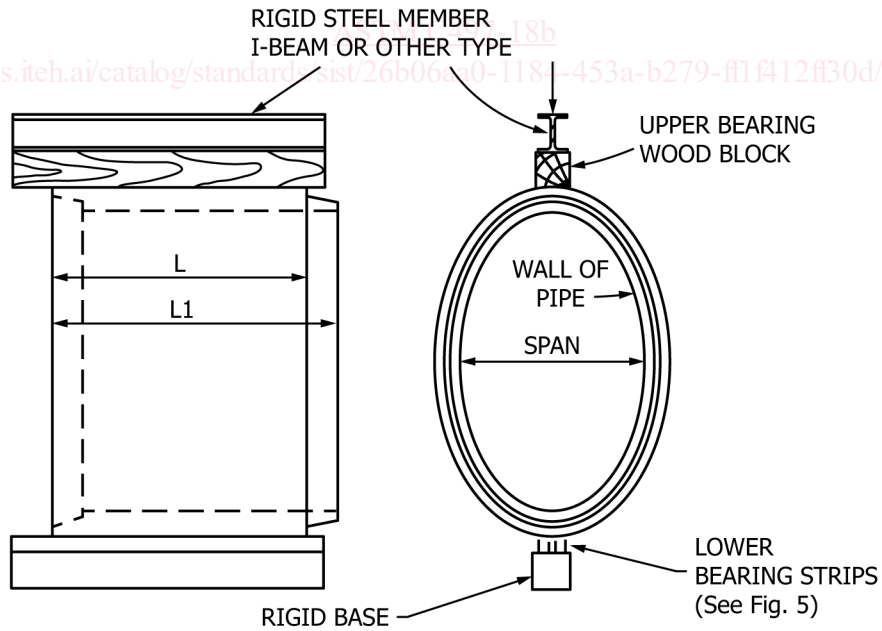

NOTE 1—The figure illustrates a method of applying the load to the pipe.
FIG. 4 Three-Edge-Bearing Test, Vertical Elliptical Pipe

4.5.3 For reinforced concrete pipe, any rate of load application up to a maximum of 7500 lbf/linear foot of pipe per minute shall be used up to 75 % of the specified design strength, at which time the rate of loading shall be reduced to a maximum uniform rate

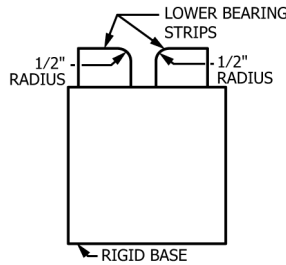

FIG. 5 Lower Bearing Strip Detail

of 1/3 of the specified design strength of the pipe per minute. This rate of loading shall be continuous until the specified acceptance design strength is reached. If both the design strength and the ultimate strength are being determined, a specified rate of loading need not be maintained after the acceptance design strength has been reached. For non-reinforced concrete pipe, any rate of load application up to a maximum of 7500 lbf/linear foot of pipe per minute shall be used up to 75 % of the specified ultimate strength, at which time the rate of loading shall be reduced to the maximum uniform rate of 3000 lbf/linear foot of pipe per minute. At the manufacturer's option, the rates of loading in this paragraph shall be any rates that do not exceed the specified maximums.

4.5.4 As defined in Terminology C822, the design strength is the maximum load, expressed as a D-load, supported by the pipe before a crack having a width of 0.01 in. occurs throughout a continuous length of 1 ft or more measured parallel to the longitudinal axis of pipe barrel. The crack is 0.01 in. in width when the point of the measuring gauge will, without forcing, penetrate 1/16 in. at 3 in. maximum intervals, throughout the specified distance of 1 ft. Measure the width of the crack by means of a gauge made from a leaf 0.01 in. in thickness (as in a set of standard machinist gauges), ground to a point of 1/16 in. in width with corners rounded and with a taper of 1/4 in./in. as shown in Fig. 6.

NOTE 2—As used in this specification, the 0.01-in. crack is a test criterion for pipe under load in three-edge bearing test and is not intended as an indication of overstressed or failed pipe under installed conditions.

4.5.5 As defined in Terminology C822, the ultimate strength is the maximum load supported by the pipe.

NOTE 3—Ultimate strength of concrete pipe in the buried condition is dependent on varying soil bedding factors and varying failure modes and shall have no relationship to the ultimate strength as defined under three-edge bearing conditions.

4.6 Conditioning—The moisture requirements of 1.3 are not required, at the option of the manufacturer.

4.7 Calculations:

4.7.1 Strength test results shall be calculated in terms of pounds per linear foot. The length used in calculating the strength values shall be that indicated by the manufactured length (L) in Figs. 1-4. For pipe with a bell, the manufactured length (L) is the length from the spigot/tongue end face to the bell/groove inside shoulder. For straight wall pipe, no bell, the manufactured length (L) is the same as for pipe with a bell or the alternate of the length from the spigot/tongue outside shoulder to the socket/groove end face. For plain end or cut pipe, no bell or spigot, the manufactured length (L) is the same as the overall length (L₁). For pipe having a spigot on one end with the opposite end being plain, the manufactured length (L) shall be the distance from the plain end to the center of the joint. For pipe having a bell on one end with the opposite end being plain, the manufactured length (L) shall be the distance from the plain end to the bell inside shoulder. See Terminology C822 for definitions of manufactured length (L) and overall length (L₁).

4.7.2 The ultimate strength in pounds per linear foot shall be calculated by dividing the maximum test load applied to the pipe by the manufactured length (L).

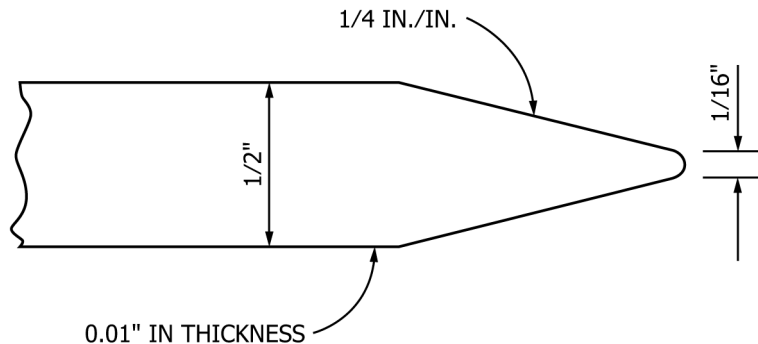

FIG. 6 Gauge Leaf for Measuring Cracks

4.7.3 The D-load strength in pounds per linear foot per foot of inside diameter or horizontal span shall be either the 0.01-in. crack D-load strength or the ultimate D-load strength. The 0.01-in. crack D-load shall be calculated by dividing the test load required to produce the 0.01-in. crack by the manufactured length (L) and by the pipe inside diameter or horizontal span. The ultimate D-load strength shall be calculated by dividing the ultimate test load applied to the pipe by the manufactured length, (L), and by the pipe inside diameter or horizontal span.

4.8 *Precision and Bias*—The user of these test methods is advised that the true value for the strength of a concrete pipe cannot be determined because the specimen is tested to destruction and exact duplicate specimen cannot be obtained. Therefore, no calculations of precision and bias are presently capable of being performed. Specifications that include this test method for the various types of concrete pipe should include a provision for additional tests of one or more specimens.

5. Flat Slab Top Test Method

5.1 *Summary of Test Method*—A load is applied to the flat slab top and the supporting capacity of the flat slab top is measured.

5.2 *Significance and Use*—The test method is a proof of design test performed to prove the adequacy of the design.

5.3 *Conditioning*—The moisture requirements of 1.3 are not required, at the option of the manufacturer.

5.4 *Procedure*—Place the section that has been designated to receive the flat slab top on a firm, even surface. Assemble the flat slab top to this section. If a frame or riser has been designed to be fitted to the access portion of the flat slab top, assemble it to the slab top. Apply the test load to the riser or frame as assembled to the flat slab top. If no access opening has been provided to the flat slab top, apply the test load to the center of the flat slab top by means of a 12 by 12 by 4-in. wood bearing block. See Fig.

7. Calculate the test load as follows:

$$P_u = 1.3 D + 2.17L(1 + I) \tag{1}$$

where:

- P_u = applied minimum ultimate proof-of-design test load, lb,
- D = total calculated field dead load on the slab, lb,
- L = calculated live load on the flat slab top, and
- I = impact factor, 30 % minimum.

6. Base Section Test Method

6.1 *Summary of Test Method*—A load is applied to the base section and the supporting capacity of the base section is measured (See 1.7 for safety concerns).

6.2 *Significance of Use*—The test method is a proof of design test performed to prove the adequacy of the design.

6.3 *Conditioning*—The temperature requirements of 1.3 are not required, at the option of the manufacturer.

6.4 *Procedure*—Place the Type (1) or (2) base section or the Type (3) base section riser that has been designed to be seated on the base, upside down on a firm, even surface. Assemble the Type (3) base to the riser section. Apply the test load to the center of the base section by means of a load distribution block. The load distribution block, if circular shall not be more than 60 % of the slab diameter or manhole riser OD, whichever is smaller. If the distribution block is rectangular, the diagonal shall not be more than 60 % of the slab diameter or manhole riser OD, whichever is less (see Figure 7c - 7f). The load distribution block shall be wood and placed on a rubber bearing pad. Calculate the test load as follows:

$$P_u = 1.3D + 2.17L(1 + I) - B \tag{2}$$

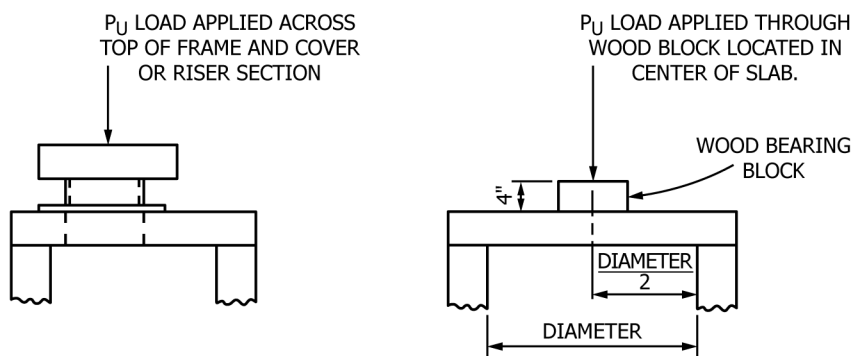

7a. FLAT SLAB TOP WITH ACCESS OPENING 7b. FLAT SLAB TOP WITHOUT ACCESS OPENING

FIG. 7 Flat Slab Top Test

TYPES OF BASE SECTIONS

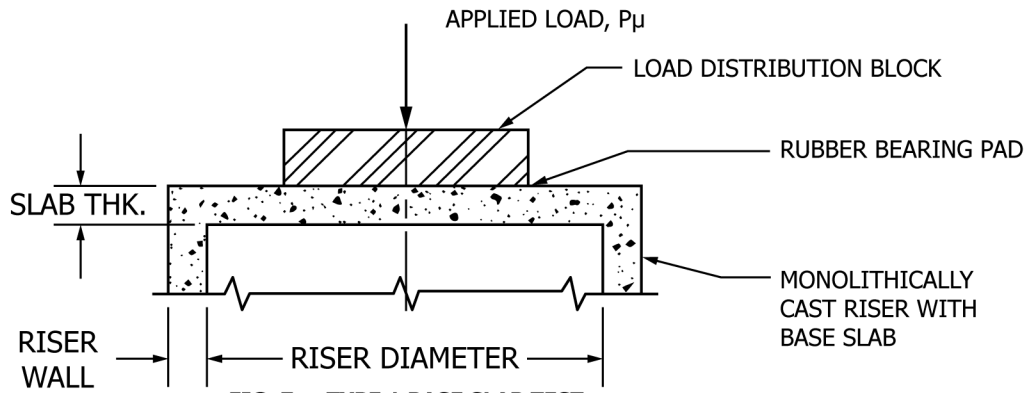

FIG. 7c - TYPE 1 BASE SLAB TEST

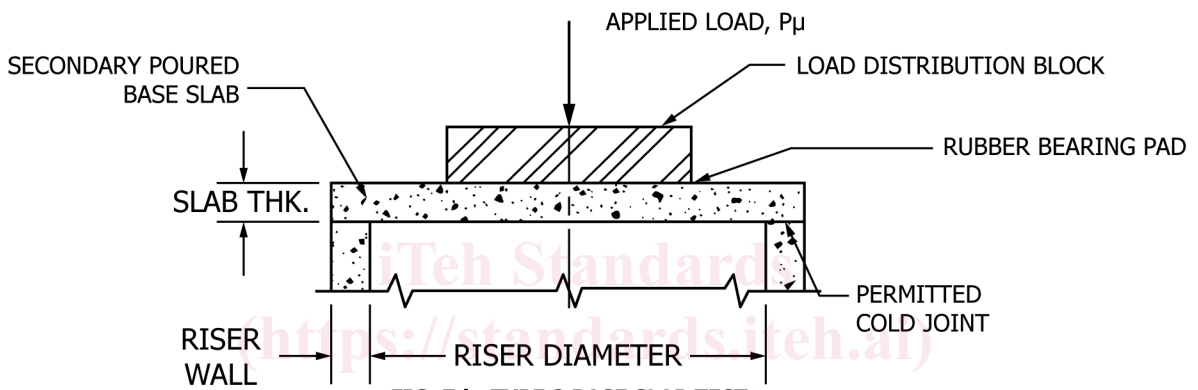

FIG. 7d - TYPE 2 BASE SLAB TEST

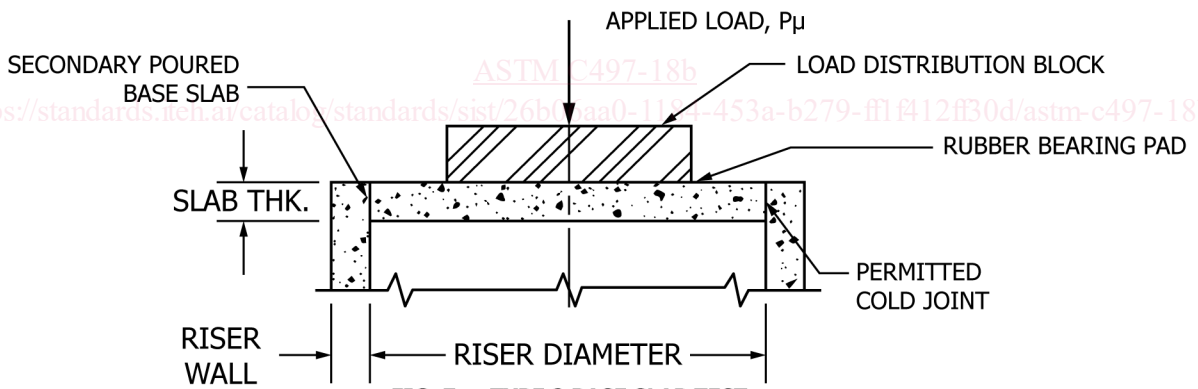

FIG. 7e - TYPE 2 BASE SLAB TEST

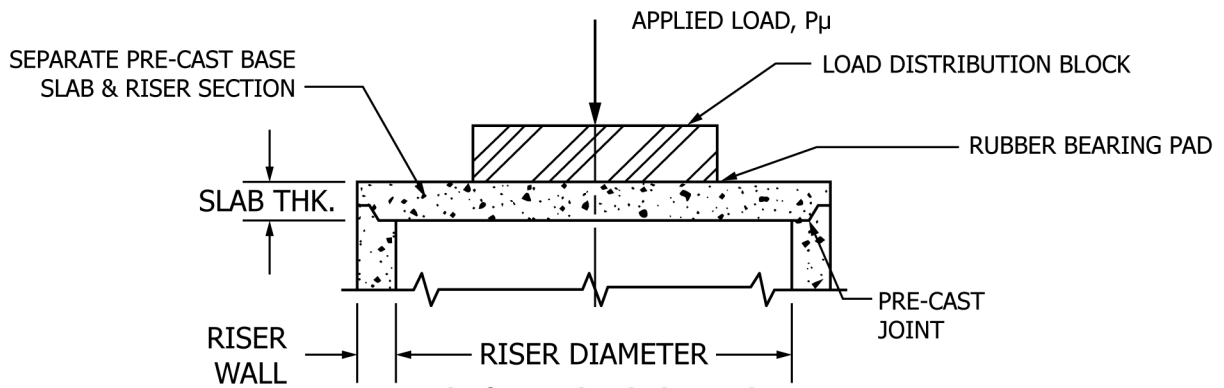

FIG. 7f - TYPE 3 BASE SLAB TEST

FIG. 7 (continued)

where:

- P_u = applied minimum ultimate proof-of-design test load, lb,
- D = total calculated field dead load on the base section, lb,
- L = calculated live load, lb,
- I = impact factor, 30 % minimum, and
- B = calculated weight of the bearing block, lb.

If hydrostatic head pressure is found to be present, the following may, at the option of the owner, be added to the minimum ultimate proof-of-design test load, P_u :

$$P_w = 1.1 * \gamma * H_h * S_A \quad (3)$$

where:

- P_w = hydrostatic head force acting on base section, psf,
- γ = water weight, pcf,
- H_h = hydrostatic head based on depth of water above base section, ft, and
- S_A = surface area of base section on which the hydrostatic force acts upon, sq.ft.

7. Core Strength Test Method

7.1 *Summary of Test Method*—The compressive strength of the concrete in the pipe is determined by making crushing tests of cores cut from the pipe.

7.2 *Significance and Use*—The core strength test is a quality control test performed to establish the fact that the finished, shippable precast concrete product had sufficient concrete strength to meet the strengths stated in the specifications.

7.3 *Apparatus*—A core drill shall be used for securing cylindrical core specimens from the wall of the pipe; a shot drill or a diamond drill shall be used.

7.4 Test Specimens:

7.4.1 A core specimen for the determination of compressive strength shall have a diameter at least three times the maximum size of the coarse aggregate used in the concrete. If cores are cut from the wall of the pipe and tested, the length to diameter ratio shall lie between one and two after the curved surfaces have been removed from the cut core.

7.4.2 *Moisture Conditioning*—Unless the agency for which the testing is being done directs otherwise, the core test specimens shall be submerged in lime-saturated water in accordance with the provisions of Test Method C42/C42M.

7.5 Procedure:

7.5.1 *End Preparation and Capping*—Core specimens to be tested in compression shall have ends that are essentially smooth and perpendicular to the axis and of the same diameter as the body of the specimen. Before making the compression test, cap the ends of the specimen in order to meet the requirements of Practice C617.

7.5.2 *Measurement*—Prior to testing, measure the length of the capped specimen to the nearest 0.1 in. and determine its average diameter to the nearest 0.1 in. from two measurements taken at right angles near the center of the length.

7.5.3 Test specimens as prescribed in Section 5 of Test Method C39/C39M. See also Practice C31/C31M.

7.6 *Calculation and Report*—Calculate the compressive strength of each specimen in pounds-force per square inch based on the average diameter of the specimen. If the ratio of length to diameter is less than two, make allowance for the ratio of length to diameter by multiplying the compressive strength by the applicable correction factor given in the following table (determine values not given in the table by interpolation):

Ratio Length of Cylinder to Diameter, l/d	Strength Correction Factor
1.75	0.98
1.50	0.96
1.25	0.93
1.10	0.89
1.00	0.87

7.7 *Precision and Bias*—The user of this test method is advised that this method for testing concrete pipe for strength is considered satisfactory for acceptance testing of commercial shipments since the test method has been used extensively for acceptance testing. In cases of disagreement arising from differences in values reported by the owner and the manufacturer when using this test method for acceptance testing, the statistical bias, if any, between the laboratory of the owner and the laboratory of the manufacturer should be determined with each comparison being based on testing specimens randomly drawn from one pipe of the type being evaluated.

8. Absorption Test Method

8.1 *Summary of Test Method*—This test method covers the testing of a specimen that is a sample or core from the wall of the pipe. The test specimen is first subjected to drying, then to immersion to determine the specimen's absorption of water when tested by the described procedures. Two alternative procedures for conducting the test are presented. Test Method A is the standard test and referee and will require 3 to 6 days to complete. Test Method B is intended as an accelerated test that requires about 1½ days to complete.

8.2 *Significance and Use*—The test method is a quality control test performed to establish the fact that the finished, shippable pipe meets the absorption limits stated in the specifications.

8.3 Test Specimens:

8.3.1 *Test Method A Specimens*—Test Method A absorption test specimens shall be in accordance with the requirements of the applicable pipe specification and shall be used for the absorption procedure that requires 5 h for boiling and a natural water cooling period of 14 to 24 h.

8.3.2 *Test Method B Specimens*—Test Method B absorption test specimens shall consist of three 1½-in. diameter cores as taken from the two ends and the center area of each tile, pipe, or section.

8.4 Procedure for Boiling Absorption Test Method:

8.4.1 *Drying Specimens*—Dry specimens in a ventilated mechanical convection oven at a temperature of 221 to 239°F.

8.4.1.1 *Test Method A*—Dry specimens until two successive weighings at intervals of not less than 6 h show an increment of loss not greater than 0.10 % of the last oven-dry mass of the specimen. Dry specimens with a wall thickness of 1.5 in. or less for a minimum of 24 h; dry specimens with a wall thickness of 1.5 to 3 in. for a minimum of 48 h; dry specimens with a wall thickness exceeding 3 in. for a minimum of 72 h. Use the last 6 h of the minimum drying time to determine whether or not the sample had obtained the proper dried mass.

8.4.1.2 *Test Method B*—Dry specimens for a minimum of 24 h.

8.4.2 *Weighing Dried Specimens*—Weigh the oven-dried specimens immediately upon removal from the oven where the drying temperature is 221 to 239°F.

8.4.3 Immersion and Boiling:

8.4.3.1 *Test Method A Specimen*—Within 24 h, carefully place the dried specimen that has been weighed in a suitable receptacle that contains clean water at a temperature of 50 to 75°F. Use distilled water, rain water, or tap water that is known to have no effect on test results. Heat the water to boiling in not less than 1 h and not more than 2 h. Do not apply live steam to the water to shorten the preboil period until 1 h of heating by gas or electricity has been completed. Continue the boiling for 5 h. At the end of the 5-h boiling period, turn off the heat, and allow the specimen to cool in the water to room temperature by natural loss of heat for not less than 14 h nor more than 24 h.

8.4.3.2 *Test Method B Specimen*—Within 24 h, carefully place the dried specimen that has been weighed in a suitable receptacle that contains clean water at a temperature of 50 to 75°F. Use distilled water, rain water, or tap water that is known to have no effect on test results. Heat the water to boiling in not less than 1 h and not more than 2 h. Do not apply live steam to the water to shorten the preboil periods until 1 h of heating by gas or electricity has been completed. Continue the boiling for 3 h. At the end of the 3-h boiling period, turn off the heat and cool the specimen for a period of 3 h by running cold tap water into the boiler, or by placing the specimen in a separate container of water. The temperature of the cooling water shall not exceed 65°F.

8.4.4 *Reweighing Wet Specimens*—Remove the water-cooled specimens from the water, place on an open drain rack, and allow to drain for 1 min. Remove the remaining superficial water by quickly blotting the specimen with a dry absorbent cloth or paper. Weigh the specimen immediately following blotting.

8.4.5 *Scale Sensitivity*—Weigh specimens weighing less than 1 kg to an accuracy of 0.10 % of the specimen mass. Weigh specimens weighing more than 1 kg to an accuracy of 1 g.

8.5 Calculation and Report:

8.5.1 *Test Method A Specimen*—Take the increase in mass of the boiled specimen over its dry mass as the absorption of the specimen, and express it as a percentage of the dry mass. Report the results separately for each specimen.

8.5.2 *Test Method B Specimen*—Take the increase in mass of the boiled specimen over its dry mass as the absorption of the specimen, and express it as a percentage of the dry mass. Report the result as an average of the three 1½-in. diameter cores as taken from one tile or pipe. The absorption, as calculated by the Test Method B procedure, shall be considered satisfactory when its value does not exceed a value that is 0.5 % less than the absorption designated in the Test Method A procedure. When the absorption, as computed by the Test Method B procedure, does not meet the specified requirement, the manufacturer is not permitted from performing a retest using Test Method A.

8.6 *Procedure for 10-Min Soaking Absorption Test*—Test specimens for the determination of the 10-min water soaking absorption shall be the same as are later used for the 5-h boiling absorption test. After drying and weighing as specified in

7.4.18.4.1 and 7.4.28.4.2, immerse the specimens in clear water for 10 min at room temperature. Then remove the specimens and weigh in accordance with 7.4.48.4.4, calculate the percentage absorption, and report in accordance with the provisions described in 7.58.5.

NOTE 4—There is no significant correlation between the results of this test and those of Test Method A or Test Method B.

8.7 *Precision and Bias*—The user of these test methods are advised of the following:

8.7.1 *Single-Operator Precision*:

8.7.1.1 *Test Method A*—The single operator standard deviation has been found to be 0.143 %. Therefore, results of two properly conducted tests by the same operator on the same material should not differ by more than 0.40 %.

8.7.1.2 *Test Method B*—The single operator standard deviation has been found to be 0.157 %. Therefore, results of two properly conducted tests by the same operator on the same material should not differ by more than 0.44 %.

NOTE 5—The numbers in 7.7.1.18.7.1.1 and 7.7.1.28.7.1.2 represent, respectively, the (1S) and (D2S) limits described in Practice C670.

8.7.1.3 *10-Min Soak Test Method*—Precision for this test method has not been determined but is being investigated. A statement will be included when proper data have been collected and analyzed.

8.7.2 *Multilaboratory Precision*—Multilaboratory precision of Test Methods A, B, and the 10-min soak test method have not been determined but are being investigated. Statements will be included for each when the proper data have been obtained and analyzed.

8.7.3 *Bias*—Bias for Test Methods A, B, and the 10-min soak test method cannot be determined since the true value of absorption is not known and cannot be determined except by application of tests for which the bias is not known.

9. Hydrostatic Test Method

9.1 *Summary of Test Method*—The section of pipe or manhole is subjected to hydrostatic pressure and observed for leakage at the joint or on the surface of the wall. The joint is defined as a connection between the concrete section of pipe or manhole that provides alignment and the flexible watertight seal using either rubber gaskets, sealing bands, or preformed flexible joint sealant.

9.2 *Significance and Use*—The test method is a quality control test performed to establish the fact that the finished, shippable pipe or manhole meets the hydrostatic requirements stated in the specifications for the installed wall or joint, or both.

9.3 *Procedure*:

9.3.1 The equipment for making the test shall be such that, when the specimen under test is filled with water to the exclusion of air and subject to the required hydrostatic pressure, there shall not be enough leakage of water from the ends of the pipe to interfere with the test. The specimen under test shall be free of all visible moisture prior to the initiation of the test.

9.3.2 Do not test when the temperature of the specimen, the air around the specimen, or the water within the specimen is below 33°F.

9.3.3 If the joint seal or flexible connector is being tested, it shall be the sole element providing joint watertightness. No mortar or concrete coatings, fillings, or packing shall be used prior to the test.

9.3.4 Connect a standardized pressure gauge to the specimen. If being tested in a vertical position, the gauge shall be placed at or as close to as is practical above the joint or section being tested. If being tested in a horizontal position, the gauge shall be placed to measure pressure at or as close to as practical above the horizontal axis. Raise the pressure of the water in approximately 1 min to the required level and hold for the specified time. There shall be no visible leakage. Moisture appearing in the form of patches or beads adhering to the surface shall not be considered leakage. If leakage occurs, the manufacturer is not prohibited from extending the soak time to 24 h.

9.3.5 If the owner does not require the wall of the pipe to be tested, the manufacturer has the option to test the pipe joint for watertightness to the parameters established in 8.3.49.3.4 by methods that pressurize the joint either internally or externally.

9.4 *Precision and Bias*—No justifiable statement is presently capable of being made either on precision or on the bias of this method of testing for leakage under hydrostatic pressure since the test result merely states whether there is conformance to the criteria for success specified.

10. Permeability Test Method

10.1 *Summary of Test Method*—A section of pipe is kept filled with water for a specified time and the outer surface is tested for moisture.

10.2 *Significance and Use*—The test method is a quality control test performed to establish the fact that the finished, shippable pipe meets the leakage limits stated in the specifications.

10.3 *Procedure*—The pipe specimen under test shall be free of all visible moisture prior to the initiation of the test. Perform tests by placing the specimen to be tested, with the spigot end down on a soft rubber mat or its equivalent, weighted if necessary, and kept filled with water to a level of the base of the socket during the test period. Make the initial inspection approximately 15 min