



Designation: D6916 – 18

# Standard Test Method for Determining the Shear Strength Between Segmental Concrete Units (Modular Concrete Blocks)<sup>1</sup>

This standard is issued under the fixed designation D6916; the number immediately following the designation indicates the year of original adoption or, in the case of revision, the year of last revision. A number in parentheses indicates the year of last reapproval. A superscript epsilon ( $\epsilon$ ) indicates an editorial change since the last revision or reapproval.

## 1. Scope

1.1 This test method is used to determine the shear strength between two layers of segmental concrete block units used in construction of reinforced soil retaining walls. The test is carried out under conditions determined by the user that reproduce the facing system at full scale. The results of a series of tests are used to define a relationship between shear strength developed between segmental concrete units and normal load.

1.2 This is a performance test used to determine properties for design of retaining wall systems utilizing segmental concrete units and soil reinforcing geosynthetics, either geotextiles or geogrids. The test is performed on a full-scale construction of the facing system and may be run in a laboratory or the field.

1.3 The values stated in SI units are regarded as the standard. The values stated in inch-pound units are provided for information only.

1.4 *This standard does not purport to address all of the safety concerns, if any, associated with its use. It is the responsibility of the user of this standard to establish appropriate safety, health, and environmental practices and determine the applicability of regulatory limitations prior to use.*

1.5 *This international standard was developed in accordance with internationally recognized principles on standardization established in the Decision on Principles for the Development of International Standards, Guides and Recommendations issued by the World Trade Organization Technical Barriers to Trade (TBT) Committee.*

## 2. Referenced Documents

### 2.1 ASTM Standards:<sup>2</sup>

**D448 Classification for Sizes of Aggregate for Road and Bridge Construction**

<sup>1</sup> This test method is under the jurisdiction of ASTM Committee D35 on Geosynthetics and is the direct responsibility of Subcommittee D35.01 on Mechanical Properties.

Current edition approved July 15, 2018. Published August 2018. Originally approved in 2003. Last previous edition approved in 2011 as D6916 – 06c (2011). DOI: 10.1520/D6916-18.

<sup>2</sup> For referenced ASTM standards, visit the ASTM Web Site, [www.astm.org](http://www.astm.org), or contact ASTM Customer Service at [service@astm.org](mailto:service@astm.org). For *Annual Book of ASTM Standards* volume information, refer to the standard's Document Summary page on the ASTM web site.

**D4354 Practice for Sampling of Geosynthetics and Rolled Erosion Control Products (RECPs) for Testing**  
**D4439 Terminology for Geosynthetics**  
**D4595 Test Method for Tensile Properties of Geotextiles by the Wide-Width Strip Method**  
**D6637/D6637M Test Method for Determining Tensile Properties of Geogrids by the Single or Multi-Rib Tensile Method**

## 3. Terminology

### 3.1 Definitions:

3.1.1 *displacement criteria, n*—a user-prescribed maximum movement, mm (in.), of the top segmental concrete unit out from the back of lower segmental concrete units.

3.1.2 *geosynthetic, n*—a planar product manufactured from polymeric material used with soil, rock, earth, or other geotechnical engineering-related material as an integral part of a manmade project, structure, or system. **D4439**

3.1.3 *granular infill, n*—coarse-grained soil aggregate used to fill the voids in and between segmental concrete units.

3.1.4 *peak shear strength, n*—the maximum shear capacity between segmental concrete units.

3.1.5 *segmental concrete depth, n*—the segmental concrete unit dimension perpendicular to the wall face.

3.1.6 *segmental concrete unit (modular concrete block), n*—a concrete unit manufactured specifically for mortarless, dry-stack retaining wall construction.

3.1.7 *segmental concrete unit width, n*—the segmental concrete unit dimension parallel to the wall face.

3.2 For definitions of other terms relating to geosynthetics, refer to Terminology **D4439**.

## 4. Summary of Test Method

4.1 In this test method, segmental concrete units are assembled in two rows (layers). The bottom row is laterally restrained. The top row is loaded vertically to a constant surcharge load, and the interface is sheared at a constant rate of displacement until a drop of load after the peak load occurs. The test may be run with the geosynthetic reinforcement sandwiched between the two rows of segmental concrete units

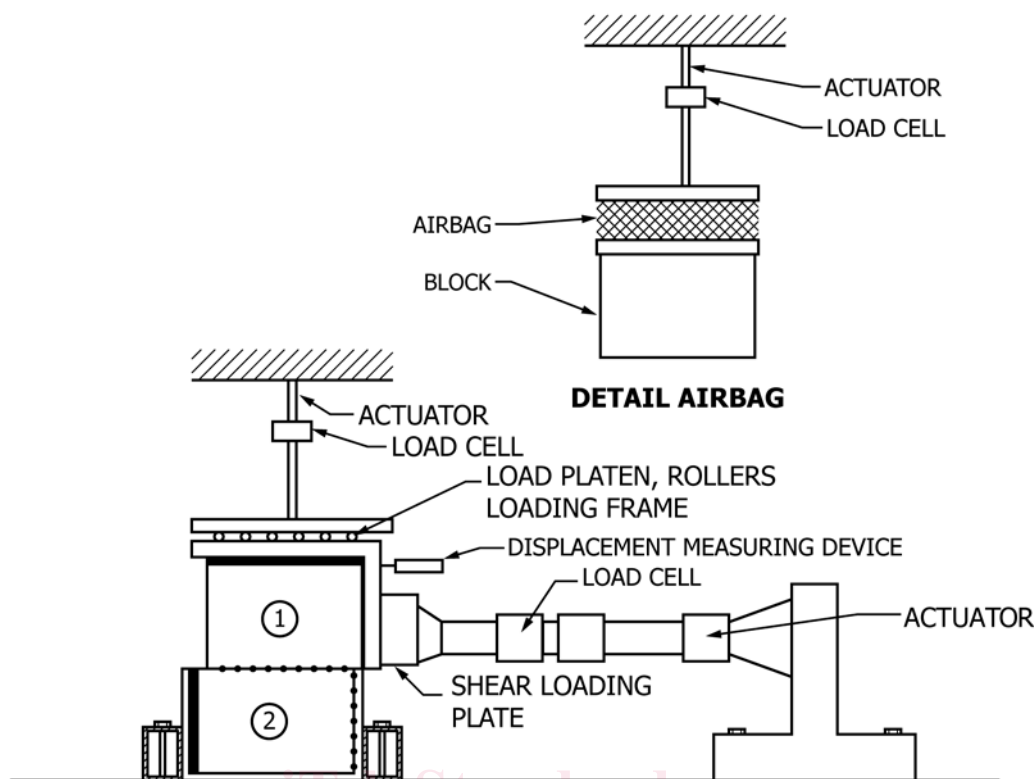

FIG. 1 Shear Test Apparatus (Cross Section View)

to determine the shear strength between segmental concrete units at the connection between the units and the geosynthetic reinforcement.

## 5. Significance and Use

5.1 The shear strength between segmental concrete units (with and without geosynthetic reinforcement) is used in design of reinforced soil retaining walls.

5.2 This test is used to determine the shear strength for the design of the facing stability of segmental retaining walls. Performing a series of these shear tests at varying normal loads permits development of a relationship between shear strength and normal load. This relationship may be linear, bilinear, or some other complex mathematical expression.

5.3 This shear strength test is meant to be a performance test (laboratory or field); therefore, it should be conducted using full-scale system components. The conditions for the test are selected by the user and are not for routine testing.

5.4 As a performance test on full-scale system components, it accounts for some of the variables in construction procedures and materials tolerance normally present for these types of retaining wall systems.

## 6. Apparatus

6.1 *Testing System*—An example of a test apparatus and setup is illustrated in Fig. 1. The principal components of the test apparatus are:

6.1.1 *Loading Frame*.

6.1.2 *Normal Load Piston/Actuator*.

6.1.3 *Vertical Loading Platen*, with stiff rubber mat or airbag to apply uniform vertical pressure to top of concrete blocks.

6.1.4 *Vertical Load Cell*, to measure normal load.

6.1.5 *Horizontal Piston/Actuator*, to apply horizontal load on the top segmental concrete unit.

6.1.6 *Horizontal Load Cell*, to measure applied force on the top segmental concrete unit.

6.1.7 *Two (2) Horizontal Displacement Measurement Devices*, to record displacement of the top segmental concrete unit.

6.2 *Loading Frame*—The loading frame shall have sufficient capacity to resist the forces developed by the horizontal and vertical loading pistons/actuators.

6.3 *Shear Loading Plate*—The shear loading plate must be sufficiently rigid to apply a uniform force across the full width of the top course. For some segmental units, it may be necessary to apply the load through a deformable material (that is, stiff rubber) which will conform to an irregular block surface, thereby allowing for a uniform load distribution.

6.4 *Restraining Box/Plate*—A rigid restraining box/plate is required to prevent horizontal movement of the lowermost segmental concrete units during shear testing. The restraining box/plate area shall be of sufficient width and depth to accommodate the full-scale “as-manufactured” segmental concrete units being tested.

6.5 *Shear Loading Assembly*—The tensile loading unit will generally be a constant rate of extension screw jack or

hydraulic actuator that can be displacement rate controlled. The loading equipment shall have a capacity that is at least equal to 120 % of the anticipated shear strength of the segmental concrete units. The piston shall be capable of at least 150 mm (6 in.) of movement in order to facilitate test setup and to ensure that there is adequate stroke to achieve peak load. The orientation of the tensioning force shall be horizontal and perpendicular to the back of the segmental units. The horizontal loading arrangement must not permit rotation of the top concrete unit during shear.

**6.6 Load Cells**—A calibrated load cell shall be used to measure the shear force and normal load during the test. The load cell used for measuring shear shall have a capacity that is greater than or equal to 120 % of the anticipated shear force between units. The load cell used for measuring the normal surcharge load shall have a capacity that is greater than or equal to 100 % of the maximum anticipated normal load. The load cells shall be accurate to within  $\pm 0.5$  % of its full-scale range.

**6.7 Displacement Measuring Devices**—Two (2) linear variable displacement transducers (LVDTs) or similar electronic displacement measuring devices are recommended to continuously monitor the displacement of the top segmental concrete unit out from the back of the lower segmental concrete units. Alternatively, dial gauges may be read and recorded manually at regular intervals not greater than 1 min. LVDTs, dial gauges, or similar measuring devices shall be accurate to  $\pm 0.1$  mm (0.005 in.).

## 7. Sampling

### 7.1 Segmental Concrete Units:

**7.1.1** Segmental concrete units shall be full-size blocks and meet the manufacturer's material and dimensional specifications. Model or prototype units shall not be used unless it can be demonstrated that they are equivalent to production units.

**7.1.2** The user shall specify or collect (or both) a sufficient sample of representative segmental units, from a standard production lot, to construct the anticipated number of test configurations for the shear system within the testing agency's load frame and testing system.

**7.1.3** The shear interface must be constructed with full-size or modified (see **7.1.4**) segmental concrete units randomly selected from the user's sampling of a standard production lot; see **7.1.2**.

**7.1.4 Test Width**—The width of the shear interface for testing shall be constructed to a minimum of 152.4 mm (6 in.) in width. The test section shall consist of at least two bottom course segmental concrete units, with one top course segmental unit placed on top of the lower segmental concrete units. The shear interface shall include at least one typical segmental concrete unit running bond joint. The top unit must be the full width of the unit. The bottom units may be adjusted to fit into the test apparatus. Testing of segmental concrete unit widths greater than 500 mm (19.7 in.) may be represented in this test by limiting the test wall to 1000 mm (39.4 in.) in width.

**NOTE 1**—Any modification to the width of bottom units should maintain the integrity of the test shear interface and ensure that a representative (repeatable) test shear interface is maintained.

**7.1.5 Test Height**—The height of the segmental concrete unit may be reduced to facilitate handling and safety issues. Any modification to the segmental concrete unit height shall not alter the geometry of the test shear interface and shall be clearly stated in the test report (see **10.2**).

**7.1.6 Conditioning**—The segmental concrete unit test specimen shall be brought to standard temperature and relative humidity conditions for testing in a laboratory. The temperature is to be  $21 \pm 2$  °C ( $70 \pm 4$  °F) and the relative humidity  $65 \pm 10$  %. For field testing, the specimen shall be brought to ambient conditions for not less than 1 h. The temperature and humidity at the start and end of the test shall be recorded for field testing.

### 7.2 Geosynthetic (If Required):

**7.2.1** If the segmental concrete units are to be used for a geosynthetic-reinforced segmental retaining wall, then a layer of a specified geosynthetic material shall be placed between the segmental concrete units.

**7.2.2 Sampling Requirements**—The latest version of ASTM sampling protocol for geotextiles (Practice **D4354**) shall be used for the geosynthetic reinforcement material.

**7.2.3 Conditioning**—The geosynthetic reinforcement test specimen shall be brought to standard temperature and relative humidity conditions for testing in a laboratory. The temperature is to be  $21 \pm 2$  °C ( $70 \pm 4$  °F) and the relative humidity  $60 \pm 10$  %. For field testing, the specimen shall be brought to ambient conditions for not less than 1 h. The temperature and humidity at the start and end of the test shall be recorded for field testing.

**7.2.4 Specimen Width**—When included, the geosynthetic reinforcement test specimen shall be the full width of the shear test interface.

**7.2.5 Specimen Length**—The geosynthetic specimen shall have sufficient length to cover the interface surface as specified by the user. The specimen must be trimmed to provide sufficient anchorage at the actuator side of the test apparatus to prevent slippage of the front edge of the geosynthetic sample.

**7.2.6** A new geosynthetic reinforcement test specimen shall be used for each test.

**7.2.7 Number of Tests**—A sufficient number of tests shall be conducted to adequately define a relationship between shear strength and normal load. Tests shall be conducted at a minimum of five (5) unique normal loads within the range of loads typical of wall design, as directed by the user. Additionally, at least two more tests at one normal load will be necessary to verify repeatability (see **7.2.8**).

**7.2.8 Repeatability of Test Results**—The testing agency shall provide evidence of test results repeatability by conducting at least three tests at one normal load level for a specific segmental concrete unit and geosynthetic reinforcement system. The general range for repeatability of peak shear strength of these three nominally identical tests is  $\pm 10$  % from the