INTERNATIONAL STANDARD



4253

INTERNATIONAL ORGANIZATION FOR STANDARDIZATION • МЕЖДУНАРОДНАЯ ОРГАНИЗАЦИЯ ПО СТАНДАРТИЗАЦИИ • ORGANISATION INTERNATIONALE DE NORMALISATION

Agricultural tractors — Operator's seating accommodation — Dimensions

Tracteurs agricoles — Poste de conduite pour conducteur assis — Dimensions

First edition — 1977-07-01

iTeh STANDARD PREVIEW
(standards.iteh.ai)

[ISO 4253:1977](#)

<https://standards.iteh.ai/catalog/standards/sist/9ac0c7d0-882a-471a-a9ec-621012610f3c/iso-4253-1977>

UDC 631.372 : 629.11.014

Ref. No. ISO 4253-1977 (E)

Descriptors : agricultural machinery, tractors, ground-vehicle seats, work-place layout, dimensions, human factors engineering.

Price based on 2 pages

FOREWORD

ISO (the International Organization for Standardization) is a worldwide federation of national standards institutes (ISO member bodies). The work of developing International Standards is carried out through ISO technical committees. Every member body interested in a subject for which a technical committee has been set up has the right to be represented on that committee. International organizations, governmental and non-governmental, in liaison with ISO, also take part in the work.

Draft International Standards adopted by the technical committees are circulated to the member bodies for approval before their acceptance as International Standards by the ISO Council.

International Standard ISO 4253 was developed by Technical Committee ISO/TC 23, *Tractors and machinery for agriculture and forestry*, and was circulated to the member bodies in November 1975.

(standards.iteh.ai)

It has been approved by the member bodies of the following countries :

Australia	Hungary	ISO 4253:1977
Brazil	India	South Africa, Rep. of
Bulgaria	Iran	Sweden
Canada	Korea, Rep. of	Switzerland
Chile	Mexico	Turkey
Czechoslovakia	New Zealand	United Kingdom
Denmark	Poland	U.S.A.
France	Portugal	Yugoslavia
Germany	Romania	

The member bodies of the following countries expressed disapproval of the document on technical grounds :

Austria	Italy
Belgium	Spain
Finland	

Agricultural tractors – Operator's seating accommodation – Dimensions

iTeh STANDARD PREVIEW (standards.iteh.ai)

0 INTRODUCTION

The aim of this International Standard is to assist the future design of operator's seating accommodation on agricultural tractors.

centre line) to the transverse plane containing the seat reference point.

NOTE – The standard location for taking this dimension is displaced 150 mm either side of the longitudinal centre line.

1 SCOPE AND FIELD OF APPLICATION

This International Standard lays down dimensions for the operator's seat and seating accommodation on agricultural tractors with a track width above 1 200 mm.

3.2 width of seat cushion : The width measured at a horizontal distance of 150 mm forward of the seat reference point at a height of 80 mm maximum above the seat reference point.

NOTE – The measurements refer to the seat adjusted to its mid position vertically and horizontally, the suspension deflected to its mid position.

2 REFERENCES

ISO 3462, *Agricultural tractors and machinery – Seat reference point.*¹⁾

ISO 3789, *Agricultural tractors and machines – Operator's controls – Location and method of operation.*

4 ADJUSTMENT OF PEDALS AND STEERING WHEEL

The pedals shall be in a position where all free play is removed.

The steering wheel shall be adjusted to its mid position.

3 DEFINITIONS

3.1 length of seat : The horizontal distance parallel to the longitudinal plane of the vehicle, measured from the front edge of seat cushion (offset 150 mm from longitudinal

5 POSITIONING OF PEDALS

The pedals shall be placed in the following order from the left-hand side to the right-hand side : clutch (operated by left foot), brake(s) (operated by right foot). The accelerator pedal, if installed, should normally be operated by the right foot.

1) At present at the stage of draft.

6 DIMENSIONS

The dimensions and angles for the operator's seating accommodation shall be as shown in figures 1 and 2.

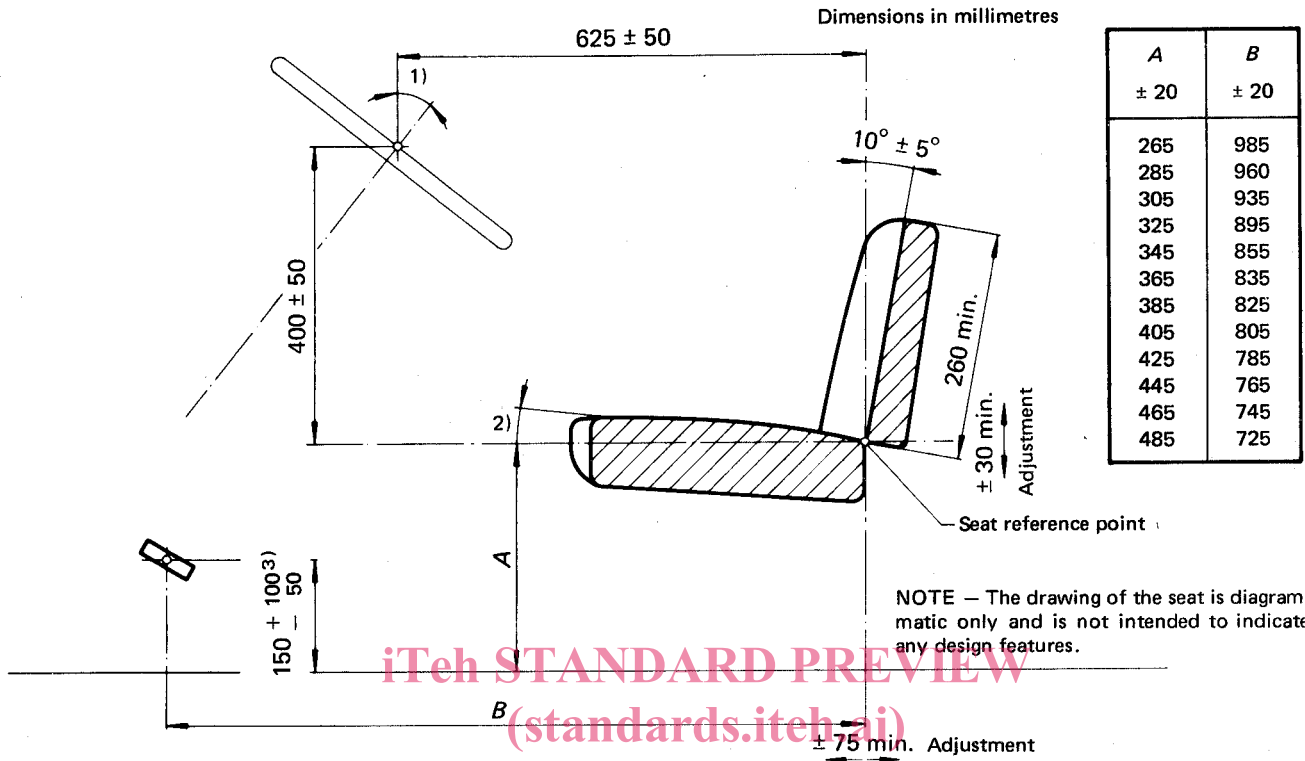

FIGURE 1 — Side view

ISO 4253:1977

<https://standards.iteh.ai/catalog/standards/sist/9ac0c7d0-882a-471a-a9ec-6210126103c/iso-4253-1977>

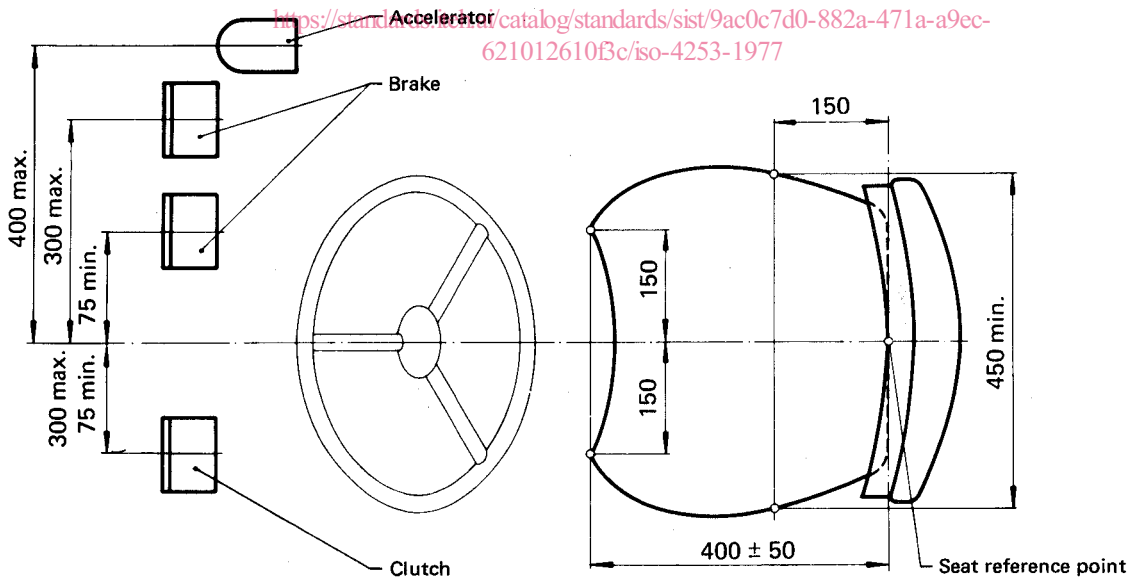

FIGURE 2 — Plan view

NOTE — The pedal locations shown in figure 2 are valid only for tractors with a flat platform.

1) The choice of angle of the steering column to the vertical is affected by the seating position, the steering wheel diameter, the steering effort, and whether power assistance is available or not. Therefore, no precise figure can be given in this International Standard at present.

2) The rearward inclination of the loaded seat cushion surface is to be 3 to 12° to the horizontal, measured with the loading device used in ISO 3462. Choice of angle of inclination within this range will depend on the seating position.

3) The height of pedals applies to brake and clutch pedals only.