



Designation: F2199 – 18

Standard Test Method for Determining Dimensional Stability and Curling Properties of Resilient Flooring after Exposure to Heat¹

This standard is issued under the fixed designation F2199; the number immediately following the designation indicates the year of original adoption or, in the case of revision, the year of last revision. A number in parentheses indicates the year of last reapproval. A superscript epsilon (ϵ) indicates an editorial change since the last revision or reapproval.

1. Scope

1.1 This test method covers the determination of the change in linear dimensions of resilient floor tile/plank products after exposure to heat and reconditioning to ambient temperature.

1.2 This test method allows one to also measure curling that can occur after a specimen has been exposed to heat and reconditioned back to ambient temperature.

1.3 The values stated in inch-pound units are to be regarded as standard. The values given in parentheses are mathematical conversions to SI units that are provided for information only and are not considered standard.

1.4 *This standard does not purport to address all of the safety concerns, if any, associated with its use. It is the responsibility of the user of this standard to establish appropriate safety, health, and environmental practices and determine the applicability of regulatory limitations prior to use.*

1.5 *This international standard was developed in accordance with internationally recognized principles on standardization established in the Decision on Principles for the Development of International Standards, Guides and Recommendations issued by the World Trade Organization Technical Barriers to Trade (TBT) Committee.*

2. Referenced Documents

2.1 *ASTM Standards:*²

[E177 Practice for Use of the Terms Precision and Bias in ASTM Test Methods](#)

[E691 Practice for Conducting an Interlaboratory Study to Determine the Precision of a Test Method](#)

[F141 Terminology Relating to Resilient Floor Coverings](#)

[F2055 Test Method for Size and Squareness of Resilient Floor Tile by Dial Gage Method](#)

¹ This test method is under the jurisdiction of ASTM Committee F06 on Resilient Floor Coverings and is the direct responsibility of Subcommittee F06.20 on Test Methods.

Current edition approved July 15, 2018. Published August 2018. Originally approved in 2002. Last previous edition approved in 2014 as F2199-09 (2014). DOI: 10.1520/F2199-18.

² For referenced ASTM standards, visit the ASTM website, www.astm.org, or contact ASTM Customer Service at service@astm.org. For *Annual Book of ASTM Standards* volume information, refer to the standard's Document Summary page on the ASTM website.

[F2421 Test Method for Measurement of Resilient Floor Plank by Dial Gage](#)

3. Terminology

3.1 Definitions are in accordance with Terminology [F141](#) unless otherwise indicated.

4. Significance and Use

4.1 The final appearance of an installed floor depends upon several factors. These include but are not limited to size and squareness in the case of tiles/planks, the quality of joint cut, the quality and preparation of the subfloor and the skill of the installer. Long term appearance of the installed floor is also dependent on but not limited to the ability of the tile/plank to resist shrinkage due to internal stress relief. This test method is used to measure the ability of the floor to retain its original dimensions following exposure to heat, simulating a long service life at reasonable and expected temperatures.

5. Apparatus

5.1 *Mechanical Convection-Type Oven, or equivalent*, capable of maintaining a default temperature of 180 ± 3.6 °F (82 ± 2 °C), with inside dimensions large enough to hold several tile/planks horizontally on aluminum exposure plates. Other temperature settings may be utilized, if specifically referenced in a resilient flooring specification. Temperature must be maintained to the same ± 3.6 °F (2 °C) accuracy of desired set point.

5.2 *Specimen Exposure Plates*, consisting of flat 14-gauge, 0.0625-in. (1.6-mm), thick aluminum. The aluminum exposure plates may be contained in a rack, either fixed in or removable from the rack, and should be at least 1 in. (25.4 mm) larger in each linear dimension than the linear dimension of the specimen tested. If contained in a rack, the spacing between each plate should be at least 0.625-in. (16-mm). The rack shall be constructed with all four sides open.

5.3 *Block and Dial Gauge Assembly*, as described in Test Method [F2055](#). See [Fig. 1](#). If testing planks longer than 24 in. (610 mm), Test Method [F2421](#) shall be utilized for size measurements.

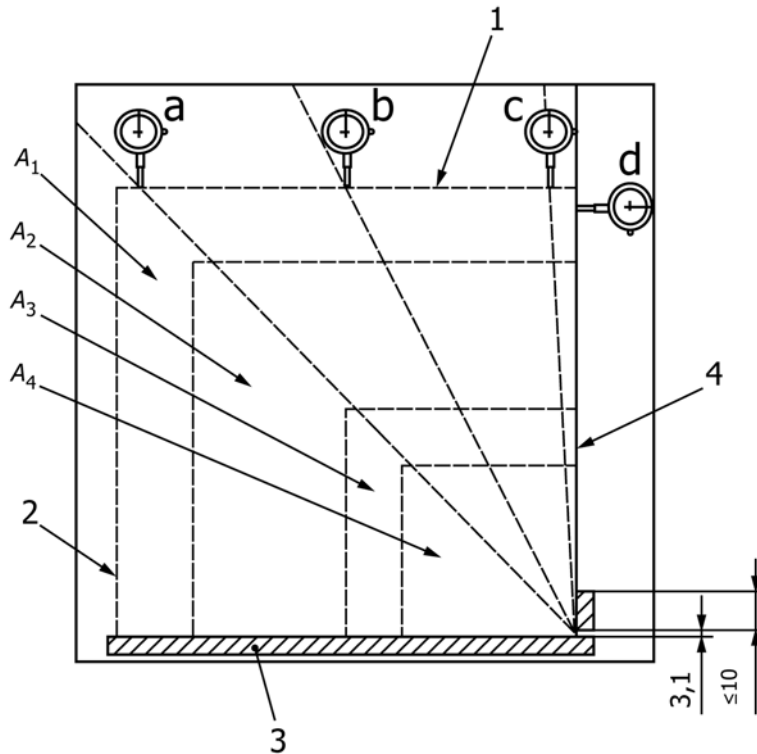

FIG. 1 Apparatus for Measuring Side Length, Straightness

Key

- 1 edge 1
- 2 edge 2
- 3 edge 3
- 4 edge 4
- a Within 10 % of the corner of the tile edge.
- b Within the central 10 % of the tile edge.
- c Within 10 % of the corner of the tile edge.
- d Within 10 % of the corner of the tile edge

- A₁ template 610 by 610 mm
- A₂ template 508 by 508 mm
- A₃ template 305 by 305 mm
- A₄ template 229 by 229 mm

(<https://standards.iteh.ai>)
Document Preview

ASTM F2199-18

<https://standards.iteh.ai/catalog/standards/sist/68a782d5-8219-4e8b-86e8-c53a57f03c90/astm-f2199-18>

5.4 *Forced Air Cooling (Fan, Blower, etc.)*, may be used for accelerating specimen conditioning before heating and after cooling exposure to ensure proper equilibrium of test specimen (see 6.1 and 7.1).

5.5 *Micrometer*; The micrometer shall be pillar-mounted, or other suitable device accurate to at least 0.001 in. (0.025 mm).

5.6 *Feeler Gauge*; Feeler gauges shall be down to 0.001 in. (0.025 mm).

5.7 *Calibrated Shim or Spacer Block*, of appropriate dimensions.

5.7.1 The calibrated shim or spacer block allows one to measure plank width differences utilizing the block and dial gauge apparatus (see Fig. 2 as an example).

5.8 *Reference Plates*, Different tile/plank sizes, with respective reference plates, can be specified, provided the size and squareness apparatus is designed to handle the testing and measurement of the different sizes.

6. Test Specimen

6.1 The test specimen consists generally of a resilient floor tile or plank. Run test in duplicate. Typical floor tile/plank dimensions are 12 by 12 in. (305 by 305 mm), 24 by 24 in. (610 by 610 mm), 5 by 48 in. (127 by 610 mm), 5 by 12 in. (127 by 305 mm) or 5 by 24 in. (127 by 610 mm); for a cut down plank. Other sizes in square or rectangular dimensions may also be tested provided the block and dial gauge can accommodate size capability and calibration requirements. If testing planks longer than 24 in. (610 mm), Test Method F2421 shall be utilized for size measurements greater than 24 in. (610 mm).

7. Conditioning

7.1 A conditioned room maintained at a temperature of 73.4 ± 1.8 °F (23 ± 1 °C) and 50 ± 5 % relative humidity.