



Designation: **D1160–15 D1160 – 18**

Standard Test Method for Distillation of Petroleum Products at Reduced Pressure¹

This standard is issued under the fixed designation D1160; the number immediately following the designation indicates the year of original adoption or, in the case of revision, the year of last revision. A number in parentheses indicates the year of last reappraisal. A superscript epsilon (ϵ) indicates an editorial change since the last revision or reappraisal.

This standard has been approved for use by agencies of the U.S. Department of Defense.

1. Scope*

1.1 This test method covers the determination, at reduced pressures, of the range of boiling points for petroleum products and biodiesel that can be partially or completely vaporized at a maximum liquid temperature of 400 °C. Both a manual method and an automatic method are specified.

1.2 In cases of dispute, the referee test method is the manual test method at a mutually agreed upon pressure.

1.3 The values stated in SI units are to be regarded as the standard. The values given in parentheses are for information only after SI units are provided for information only and are not considered standard.

1.4 *This standard does not purport to address all of the safety concerns, if any, associated with its use. It is the responsibility of the user of this standard to establish appropriate safety, health, and environmental practices and determine the applicability of regulatory limitations prior to use.* For specific warning statements, see 6.1.4, 6.1.8.1, 10.11, and A3.2.1.

1.5 *This international standard was developed in accordance with internationally recognized principles on standardization established in the Decision on Principles for the Development of International Standards, Guides and Recommendations issued by the World Trade Organization Technical Barriers to Trade (TBT) Committee.*

2. Referenced Documents

2.1 *ASTM Standards:*²

D613 Test Method for Cetane Number of Diesel Fuel Oil

D1193 Specification for Reagent Water

D1250 Guide for Use of the Petroleum Measurement Tables

D1298 Test Method for Density, Relative Density, or API Gravity of Crude Petroleum and Liquid Petroleum Products by Hydrometer Method

D4052 Test Method for Density, Relative Density, and API Gravity of Liquids by Digital Density Meter

D4057 Practice for Manual Sampling of Petroleum and Petroleum Products

D4177 Practice for Automatic Sampling of Petroleum and Petroleum Products

D6300 Practice for Determination of Precision and Bias Data for Use in Test Methods for Petroleum Products and Lubricants

3. Terminology

3.1 *Definitions of Terms Specific to This Standard:*

3.1.1 *atmospheric equivalent temperature (AET), n*—the temperature converted from the measured vapor temperature using Eq A7.1. The AET is the expected distillate temperature if the distillation was performed at atmospheric pressure and there was no thermal decomposition.

3.1.2 *end point (EP) or final boiling point (FBP), n*—the maximum vapor temperature reached during the test.

3.1.3 *initial boiling point (IBP), n*—the vapor temperature that is measured at the instant the first drop of condensate falls from the lower end of the condenser section drip tip.

¹ This test method is under the jurisdiction of ASTM Committee D02 on Petroleum Products, Liquid Fuels, and Lubricants and is the direct responsibility of Subcommittee D02.08 on Volatility.

Current edition approved Feb. 1, 2015; July 1, 2018. Published February 2015; August 2018. Originally approved in 1951. Last previous edition approved in 2013 as D1160–13; D1160–15. DOI: 10.1520/D1160-15.10.1520/D1160-18.

² For referenced ASTM standards, visit the ASTM website, www.astm.org, or contact ASTM Customer Service at service@astm.org. For *Annual Book of ASTM Standards* volume information, refer to the standard's Document Summary page on the ASTM website.

*A Summary of Changes section appears at the end of this standard

3.1.3.1 Discussion—

When a chain is attached to the drip tip the first drop will form and run down the chain. In automatic apparatus, the first drop detection device shall be located as near to the lower end of the drip tip as practical.

3.1.4 *spillover point, n*—the highest point of the lower internal junction of the distillation column and the condensing section of the vacuum-jacketed column assembly.

4. Summary of Test Method

4.1 The sample is distilled at an accurately controlled pressure between 0.13 kPa and 6.7 kPa (1 mm and 50 mm Hg) under conditions that are designed to provide approximately one theoretical plate fractionation. Data are obtained from which the initial boiling point, the final boiling point, and a distillation curve relating volume percent distilled and atmospheric equivalent boiling point temperature can be prepared.

5. Significance and Use

5.1 This test method is used for the determination of the distillation characteristics of petroleum products, biodiesel, and fractions that may decompose if distilled at atmospheric pressure. This boiling range, obtained at conditions designed to obtain approximately one theoretical plate fractionation, can be used in engineering calculations to design distillation equipment, to prepare appropriate blends for industrial purposes, to determine compliance with regulatory rules, to determine the suitability of the product as feed to a refining process, or for a host of other purposes.

5.2 The boiling range is directly related to viscosity, vapor pressure, heating value, average molecular weight, and many other chemical, physical, and mechanical properties. Any of these properties can be the determining factor in the suitability of the product in its intended application.

5.3 Petroleum product specifications often include distillation limits based on data by this test method.

5.4 Many engineering design correlations have been developed on data by this test method. These correlative methods are used extensively in current engineering practice.

6. Apparatus

6.1 The vacuum distillation apparatus, shown schematically in Fig. 1, consists in part of the components described below plus

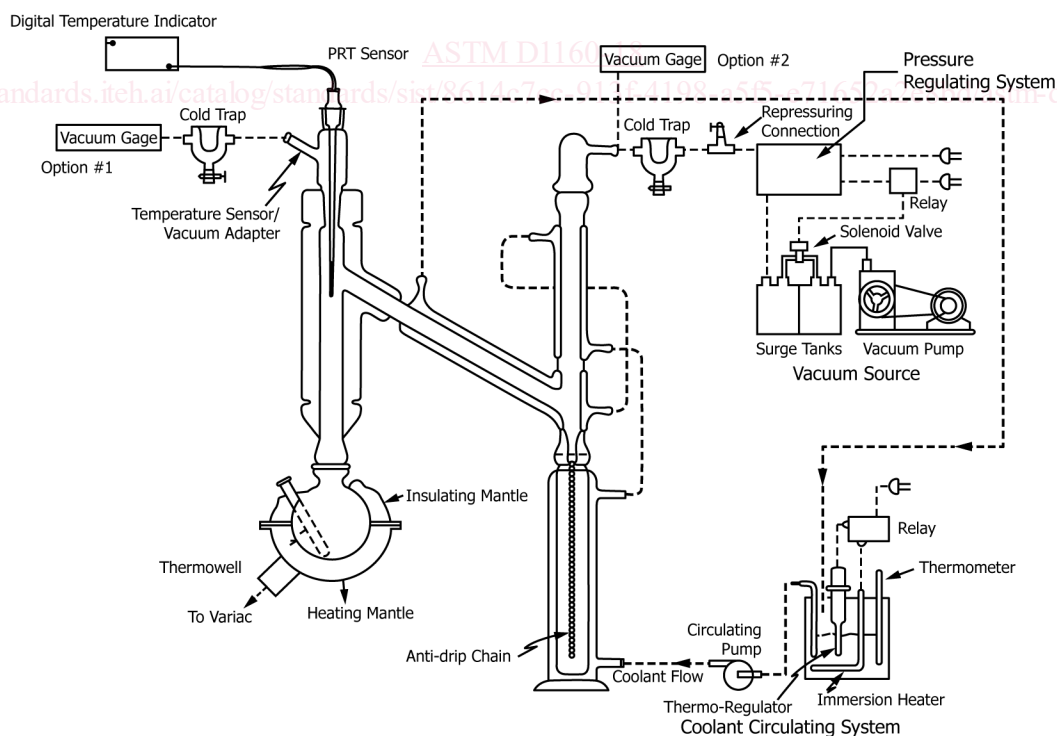

NOTE 1—A cold trap can be inserted before the pressure transducer in Option No. 2, if desired, or if the design of the transducer, such as a mercury McCleod gauge, would require vapor protection.

FIG. 1 Assembly of Vacuum Distillation Apparatus

others that appear in Fig. 1 but are not specified, either as to design or performance. Some of these parts are not essential for obtaining satisfactory results from the tests but are desirable components of the assembly for the purpose of promoting the efficient use of the apparatus and ease of its operation. Both manual and automatic versions of the apparatus must conform to the following requirements. Additional requirements for the automatic apparatus can be found in Annex A9.

6.1.1 *Distillation Flask*, of 500 mL capacity, made of borosilicate glass or of quartz conforming to the dimensions given in Fig. 2 or Fig. 3, and having a heating mantle with insulating top. These dimensions can vary slightly by manufacturer, and are not considered critical dimensions, with the exception of the position of the end of the temperature sensing probe, and the inner diameter of the connection to the distillation column not being less than the inner diameter of the distillation column. The use of the thermowell can be replaced by an encased temperature probe and the second side neck is present on commercially available flasks used in this test method.

6.1.2 *Vacuum-Jacketed Column Assembly*, of borosilicate glass, consisting of a distilling head and an associated condenser section as illustrated in the lettered drawing, Fig. 4 and Table 1. The head shall be enclosed in a completely silvered glass vacuum jacket with a permanent vacuum of less than 10^{-5} Pa (10^{-7} mm Hg) (Note 1). The attached condenser section shall be enclosed in water jackets as illustrated and have an adapter at the top for connection to the vacuum source. A light drip-chain shall hang from the drip tip of the condenser to a point 5 mm below the 10 mL mark of the receiver as shown in Fig. 5. Alternatively, instead of the metal drip-chain, a metal trough may be used to channel the distillate to the wall of the receiver. This trough may either be attached to the condenser drip tip as shown in Fig. 5 or it may also be located in the neck of the receiver.

NOTE 1—There is no simple method to determine the vacuum in the jacket once it is completely sealed. A Tesla coil can be used, but the spark can actually create a pinhole in a weak spot in the jacket. Even the slightest pinhole or crack not readily detectable by sight alone will negate the vacuum in the jacket.

6.1.3 *Vapor Temperature Measuring Device* and associated signal conditioning and processing instruments (Annex A1) for the measurement of the vapor temperature. The system must produce readings with an accuracy of ± 0.5 °C over the range 0 °C to 400 °C and have a response time of less than 200 s as described in Annex A2. The location of the vapor temperature sensor is extremely critical. As shown in Fig. 6, the vapor temperature measuring device shall be centered in the upper portion of the distillation column with the top of the sensing tip $3 \text{ mm} \pm 1 \text{ mm}$ below the spillover point (see 3.1). The vapor temperature measuring device can consist of different configurations depending if it is a platinum resistance in glass or metal, or if it is a thermocouple in glass or metal. Figs. 7 and 8 show the proper positioning of these two types in relation to the spillover point. In glass platinum resistance devices the top of the spiral winding is the top of the sensing tip, in thermocouples it is the top of the thermocouple junction, in metal jacketed devices it is $1 \text{ mm} \pm 1 \text{ mm}$ above the bottom of the device. An alignment procedure is described in Appendix X1. The vapor temperature measuring device shall be mounted through a compression ring type seal

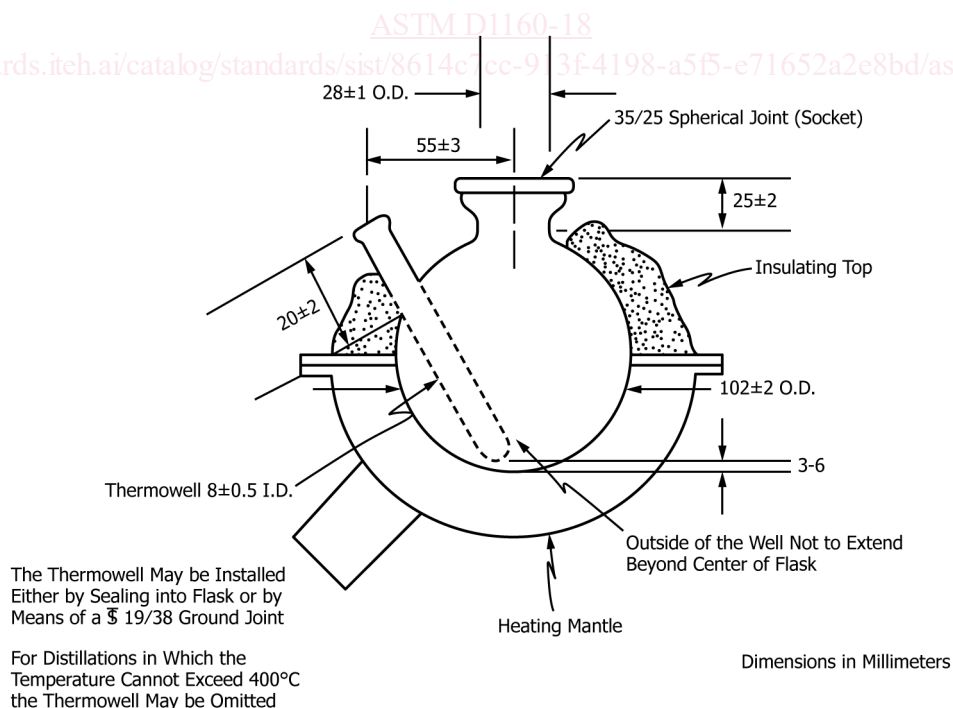

FIG. 2 Distillation Flask and Heating Mantle

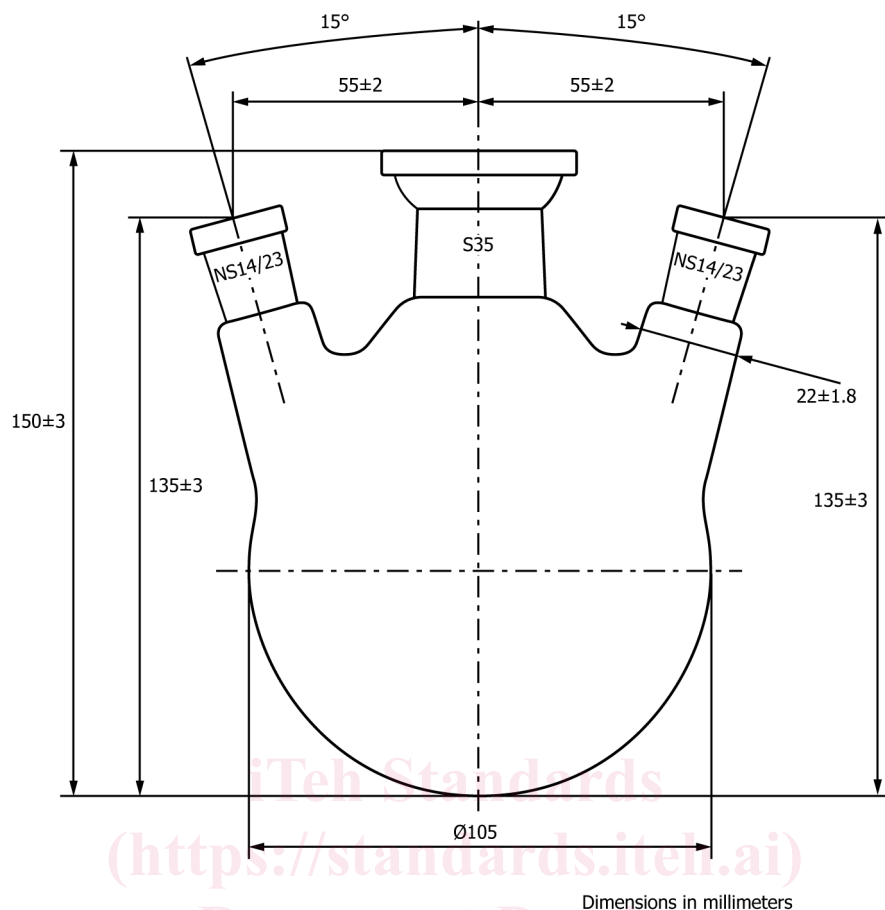

FIG. 3 Distillation Flask 500 ML

ASTM D1160-18

mounted on the top of the glass temperature sensor/vacuum adapter or fused into a ground taper joint matched to the distillation column. In some distillation apparatus configurations, the vacuum adapter at the top of the distillation column can be omitted. In these cases, the position of the vapor temperature measuring device shall be adjusted accordingly. The boiler temperature measuring device may be either a thermocouple or PRT and shall also be calibrated as above.

6.1.4 *Receiver* of borosilicate glass, conforming to the dimensions shown in Fig. 9. If the receiver is part of an automatic unit and is mounted in a thermostatted chamber, the jacket is not required. (~~Warning~~—~~Warning~~—The glass parts of the apparatus are subjected to severe thermal conditions and, to lessen the chances of failure during a test, only equipment shown to be strain-free under polarized light should be used.)

6.1.5 *Vacuum Gauge*, capable of measuring absolute pressures with an accuracy of 0.01 kPa in the range below 1 kPa absolute and with an accuracy of 1 % above this pressure. The non-tilting McLeod gauge or other analogous primary standard pressure device can achieve this accuracy when properly used, but a mercury manometer will permit this accuracy only down to a pressure of about 1 kPa and then only when read with a good cathetometer (an instrument based on a telescope mounted on a vernier scale to determine levels very accurately). Certified electronic sensors may be used, provided the calibration of the sensor and its associated recording instrument can be traced back to a primary pressure standard. A basic calibration procedure is described in Annex A3. Vacuum gauges based on hot wires, radiation, or conductivity detectors are not recommended.

6.1.5.1 Connect the vacuum gauge to the side tube of the temperature sensor/vacuum adapter of the distillation column (preferred location) or to the side tube of the sensor/vacuum adapter of the condenser when assembling the apparatus. Connections shall be as short in length as possible and have an inside diameter not less than 8 mm.

6.1.6 *Pressure Regulating System*, capable of maintaining the pressure of the system constant within 0.01 kPa at pressures of 1 kPa absolute and below and within 1 % of the absolute pressure at 1 kPa or higher. Suitable equipment for this purpose is described in Annex A4. Connect the pressure regulating system to the tube at the top of the condenser when assembling the apparatus. Connections shall be as short in length as possible and have an inside diameter not less than 8 mm.

6.1.7 *Vacuum Source*, consisting of, for example, one or more vacuum pumps and several surge tanks, capable of maintaining the pressure constant within 1 % over the full range of operating pressures. A vacuum adapter is used to connect the source to the top of the condenser (Fig. 1) with tubing of 8 mm ID or larger and as short as practical. A single stage pump with a typical capacity

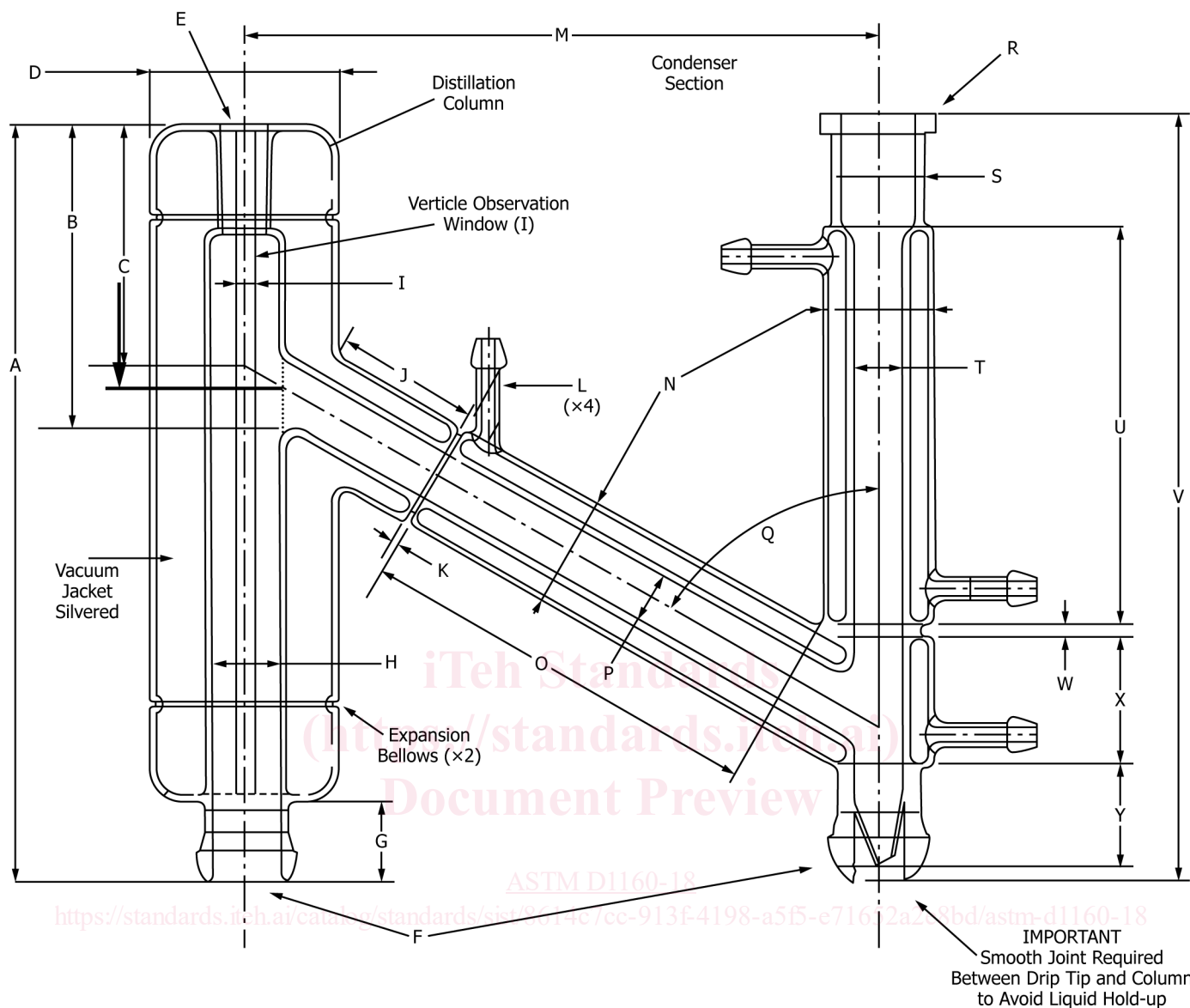

FIG. 4 Vacuum-Jacketed Column

of 85 L/min to 130 L/min (3 cfm to 4.6 cfm) capacity at 100 kPa is suitable as a vacuum source, but a double stage pump of similar or better capacity is recommended if distillations are to be performed below 0.5 kPa. Surge tanks of at least 5 L capacity are recommended to reduce pressure fluctuations.

6.1.8 Cold Traps:

6.1.8.1 Cold trap mounted between the top of the condenser and the vacuum source to recover the light boiling components in the distillate that are not condensed in the condenser section. This trap shall be cooled with a coolant capable of maintaining the temperature of the trap below -40°C . Liquid nitrogen is commonly used for this purpose. (**Warning—Warning**—If there is a large air leak in the system and liquid nitrogen is used as the coolant, it is possible to condense air (oxygen) in the trap. If hydrocarbons are also present in the trap, a fire or explosion can result when the trap is warmed up in step 10.12.)

6.1.8.2 Cold trap mounted between the temperature sensor/vacuum adapter and the vacuum gauge to protect the gauge from contamination by low boiling components in the distillate.

6.1.9 Low Pressure Air or Carbon Dioxide Source to cool the flask and heater at the end of the distillation.

6.1.10 Low Pressure Nitrogen Source to release the vacuum in the system.

6.1.11 Safety Screen or Safety Enclosure that adequately shields the operator from the distillation apparatus in the event of mishap. Reinforced glass, 6 mm thick clear plexiglass, or a clear material of equivalent strength is recommended.

6.1.12 Coolant Circulating System, capable of supplying coolant to the receiver and condenser system, at a temperature controlled within $\pm 3^{\circ}\text{C}$ in the range between 30°C and 80°C . For automatic units where the receiver is mounted in a thermostatted chamber, the coolant circulating system has to be capable of supplying coolant to the condenser system only.

TABLE 1 Vacuum-Jacketed Column Assembly Dimensions

NOTE 1—These dimensions are for guidance for verifying the appropriate construction of the assembly. The actual dimensions used by glassmakers vary to some extent, and the dimensions they use to construct the assembly are not easily obtained after the assembly is fused together. Those dimensions noted as critical shall be adhered to within the tolerance listed. The dimensions listed in this chart have been gathered from users of the various manufactured manual and automatic apparatus who participated in the interlaboratory program to produce the precision for this test method.

NOTE 2—**Important**—Further study will progress to produce a set of dimensions which will be more restrictive in range of dimension, since it is believed that the current wide variance in dimensions has resulted in precision for this test method to be significantly high. The target dimensions for this assembly and other components of the apparatus are expected to be available within the next year, with implementation expected to occur after five years of initial revised test method publication date.

Component	Critical	Dimensions ^A	Notes
A	no	265 ± 10	...
B	yes	99 ± 4	Spillover point
C	yes	85 ± 3	Internal measurement difficult, used by manufacturer for assembly. Dimension is where center of angled inner tube intersects with the inner wall of the vertical column
D (OD)	no	64.5 ± 2	...
E	no	14/23 or 19/38	Tapered ground joint – female ^B
F	no	35/25	Spherical ground joint – male ^B
G	no	35 ± 10	This area to be covered by the insulating top of the heating mantle
H (ID)	yes	24.7 ± 1.2	Use of 28 mm OD tubing achieves this dimension
I	no	2 – 12	Window allows observation of boil-up rate and column cleanliness, but also allows detrimental heat loss
J	no	60 ± 20	...
K	no	12 ± 7	...
L (OD)	no	8	Minimum, cooling medium connections
M	yes	230 ± 13	This dimension determines condensed vapor run down time and affects temperature/recovery results
N (OD)	no	38 ± 2	...
O	yes	140 ± 20	This dimension affects vapor condensing efficiency which influences temperature/recovery results
P (ID)	yes	18.7 ± 1.1	Use of 22 mm OD tubing achieves this dimension
Q	yes	60 ± 2°	...
R	no	not applicable	Connection to vacuum system; any suitable means is allowed
S	no	not applicable	Extension above condensing section; must maintain minimum or greater internal diameter of condensing section
T (ID)	yes	18.7 ± 1.1	Use of 22 mm OD tubing achieves this dimension
U	yes	140 ± 5	This dimension affects vapor condensing efficiency which influences temperature/recovery results
V	no	not applicable	Extensions on the upper and lower portions of the condensing section vary by manufacturer and have no influence on the test
W	no	12 ± 7	...
X	yes	50 ± 8	...
Y	yes	30 ± 7	Distance to end of drip tip

^A All dimensions are in millimetres.

^B Ground glass joints from different sources may have one of a number of diameter to length ratios. For purposes of this test method, any are suitable, and in some instances, the diameter itself is not critical. However, it is critical that the male and female parts of each joint are from the same series to avoid recession or protuberance.

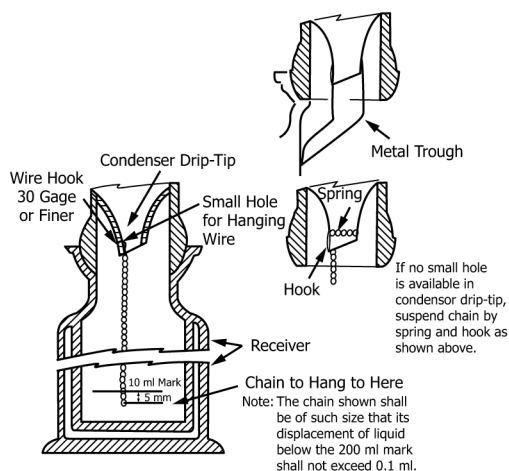
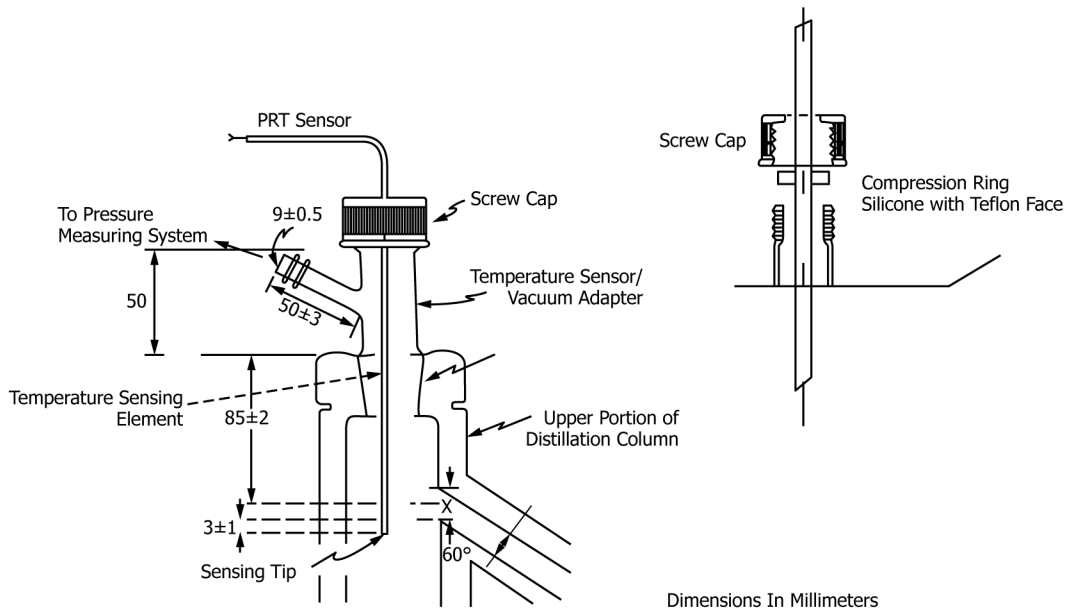

FIG. 5 Detail of Drip-Chain or Trough Attachment to Condenser



NOTE 1—Dimensions are in millimetres.
FIG. 6 Location of Temperature Sensor

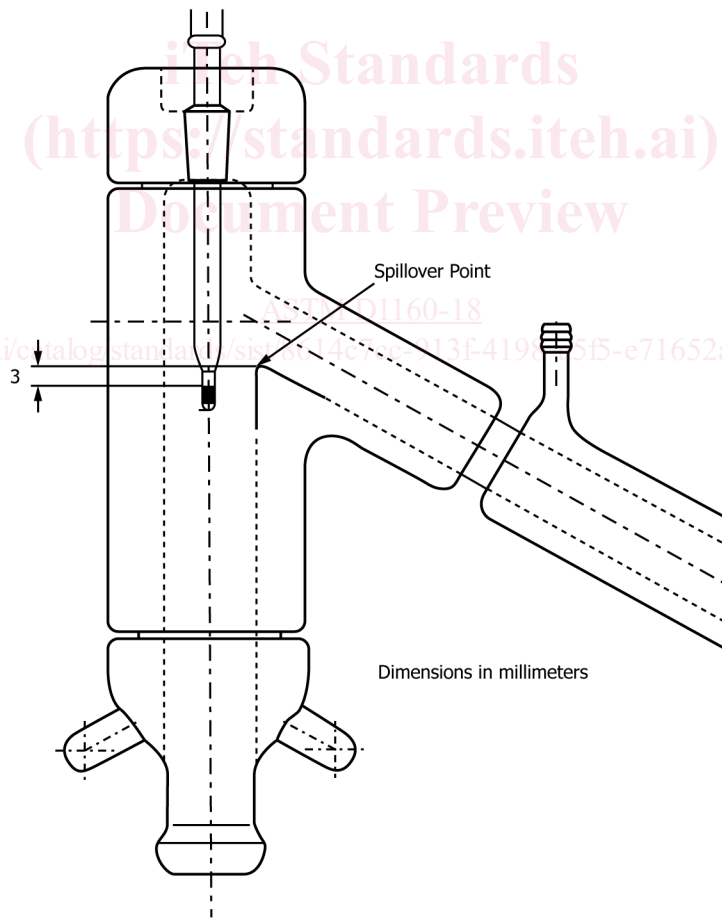

FIG. 7 Platinum Resistance Temperature Measuring Device

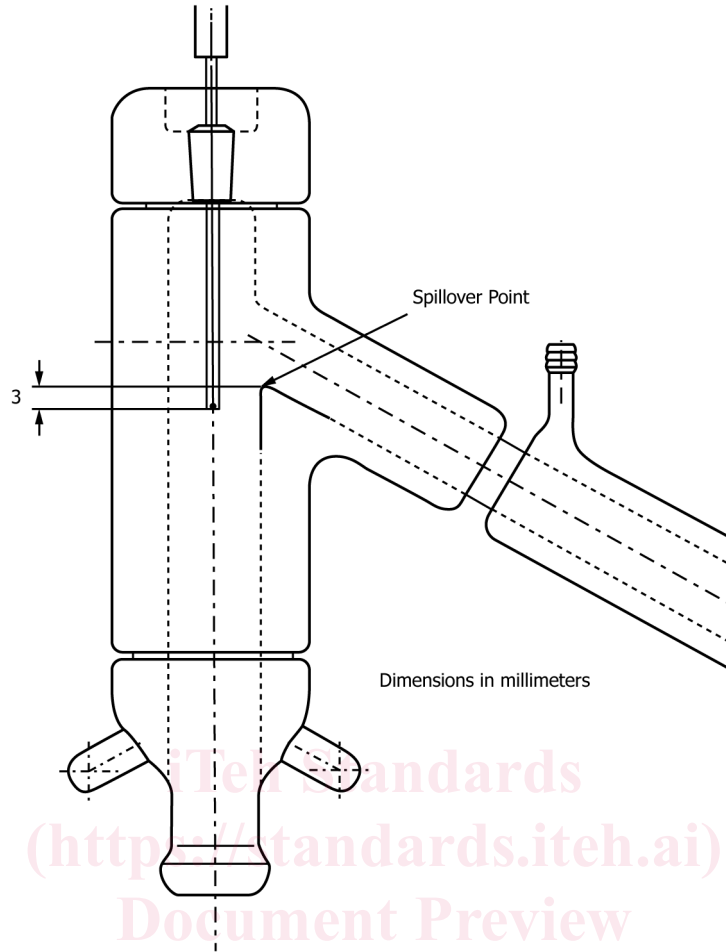
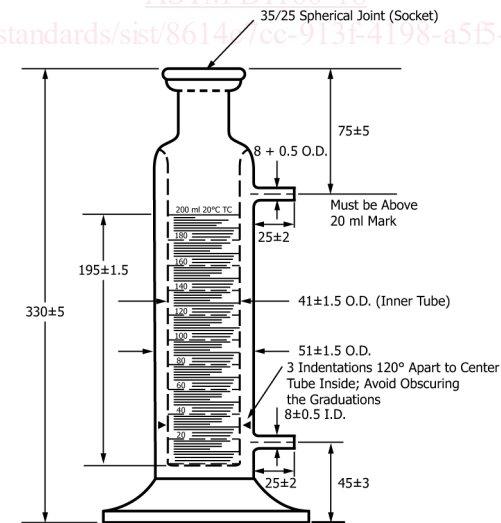

FIG. 8 Thermocouple Temperature Measuring Device

ASTM D1160-18
<https://standards.iteh.ai/catalog/standards/sist/8614e7cc-9131-4198-a5f5-e71652a2e8bd/astm-d1160-18>



Dimensions in Millimeters

Note: Jacket is not required for automatic units when receiver is placed in thermostatted chamber. If jacket is used, connections should not interfere with reading of graduations.

NOTE 1—Jacket is not required for automatic units when receiver is placed in thermostatted chamber. If jacket is used, connections should not interfere with reading of graduations.

FIG. 9 Receiver

7. Reagents and Materials

7.1 *n-Tetradecane*—Reagent grade conforming to the specifications of the Committee on Analytical Reagents of the American Chemical Society.³

7.2 *ASTM Cetane Reference Fuel (n-Hexadecane)*, conforming to the specification in Test Method **D613**.

7.3 *Silicone Grease*—High vacuum silicone grease specially manufactured for the use in high vacuum applications.

7.4 *Silicone Oil*, certified by the manufacturer to be applicable for prolonged use at temperatures above 350 °C.

7.5 *Toluene*—Technical grade.

7.6 *Cyclohexane*—Technical grade.

8. Sample and Sampling Requirements

8.1 Sampling shall be done in accordance with Practices **D4057** or **D4177**. It is assumed that a 4 L to 8 L sample, representative of a shipment or of a plant operation, is received by the laboratory and that this sample is to be used for a series of tests and analyses. An aliquot portion slightly in excess of 200 mL will be required for this test method.

8.2 The aliquot used for this test shall be moisture-free. If there is evidence of moisture (drops on the vessel wall, a liquid layer on the bottom of the container, etc.) use the procedure given in **Annex A6**, paragraph **A6.1**, to dehydrate a sufficient quantity of sample to provide the 200 mL charge to the distillation flask.

8.3 Determine the density of the oil sample at the temperature of the receiver by means of a hydrometer by Practice **D1298**, by means of a digital density meter by Test Method **D4052**, and by using either the mathematical subroutines or tables of Guide **D1250**, or a combination thereof.

8.4 If the sample is not to be tested immediately upon receipt, store at ambient temperature or below. If the sample is received in a plastic container, it shall be transferred to a container made out of glass or of metal prior to storage.

8.5 The sample shall be completely liquid before charging. If crystals are visible, the sample shall be heated to a temperature that permits the crystals to dissolve. The sample must then be stirred vigorously for 5 min to 15 min, depending on the sample size, viscosity, and other factors, to ensure uniformity. If solids are still visible above 70 °C, these particles are probably inorganic in nature and not part of the distillable portion of the sample. Remove most of these solids by filtering or decanting the sample.

8.5.1 There are several substances, such as visbroken residues and high melting point waxes, that will not be completely fluid at 70 °C. These solids and semi-solids should not be removed since they are part of the hydrocarbon feed.

9. Preparation, Calibration, and Quantification of Apparatus

9.1 Calibrate the temperature sensors and associated signal conditioning and processing device as a unit in accordance with **Annex A1**.

9.2 Check the operation of the pressure regulating system as described in **Annex A4**.

9.3 Clean and dry the glass parts and relubricate the joints. Silicone high-vacuum grease can be used but no more than is necessary to give a uniform film on the ground glass surfaces. An excess of grease can cause leaks and can contribute to foaming at startup.

9.4 Assemble the empty apparatus and conduct a leak test as described in **A3.3.2**.

9.5 Check the total apparatus using either of the two reagents described in **7.1** and **7.2** and in accordance with **Annex A5**.

10. Procedure

10.1 Determine when the temperature sensor was last calibrated. Recalibrate according to **Annex A1** if more time has elapsed than that specified in **Annex A1**.

10.2 Set the temperature of the condenser coolant to at least 30 °C below the lowest vapor temperature to be observed in the test.

NOTE 2—A suitable coolant temperature for distillation of many materials is 60 °C.

10.3 From the density of the sample determine the weight, to the nearest 0.1 g, equivalent to 200 mL of the sample at the temperature of the receiver. Weigh this quantity of oil into the distillation flask.

10.4 Lubricate the spherical joints of the distillation apparatus with a suitable grease (**Note 3**). Make certain that the surfaces of the joints are clean before applying the grease, and use only the minimum quantity required. Connect the flask to the lower

³ *Reagent Chemicals, American Chemical Society Specifications*, American Chemical Society, Washington, DC. For Suggestions on the testing of reagents not listed by the American Chemical Society, see *Annual Standards for Laboratory Chemicals*, BDH Ltd., Poole, Dorset, U.K., and the *United States Pharmacopeia and National Formulary*, U.S. Pharmacopeial Convention, Inc. (USPC), Rockville, MD.

spherical joint of the distilling head, place the heater under the flask, put the top mantle in place and connect the rest of the apparatus using spring clamps to secure the joints.

NOTE 3—Silicone high-vacuum grease has been used for this purpose. An excess of this lubricant applied to the flask joint can cause the sample to foam during distillation.

10.5 Place a few drops of silicone oil in the bottom of the thermowell of the flask and insert the temperature sensor to the bottom. The sensor can be secured with a wad of glass wool at the top of the thermowell.

10.6 Start the vacuum pump and observe the flask contents for signs of foaming. If the sample foams, allow the pressure on the apparatus to increase slightly until the foaming subsides. Apply gentle heat to assist the removal of dissolved gas. For general directions for suppression of excessive foaming of the sample, see [A6.2](#).

10.7 Evacuate the apparatus until the pressure reaches the level prescribed for the distillation ([Note 4](#)). Failure to reach the distillation pressure, or the presence of a steady increase in pressure in the apparatus with the pump blocked off, is evidence of significant leakage into the system. Bring the system to atmospheric condition using a nitrogen bleed and relubricate all joints. If this does not result in a vacuum-tight system, examine other parts of the system for leaks.

NOTE 4—The most commonly prescribed pressure is 1.3 kPa (10 mm Hg). For heavy products with a substantial fraction boiling above 500 °C, an operating pressure of 0.13 kPa (1 mm Hg) or 0.26 kPa (2 mm Hg) is generally specified.

10.8 After the desired pressure level has been attained, turn on the heater and apply heat as rapidly as possible to the flask, without causing undue foaming of the sample. As soon as vapor or refluxing liquid appears at the neck of the flask, adjust the rate of heating so that the distillate is recovered at a uniform rate of 6 mL/min to 8 mL/min ([Note 5](#)).

NOTE 5—It is extremely difficult to achieve the desired rate at the very beginning of the distillation, but this rate should be attainable after the first 10 % of the distillate has been recovered.

10.9 Record the vapor temperature, time, and the pressure at each of the following volume percentage fractions of the charge collected in the receiver: IBP, 5, 10, 20, 30, 40, 50, 60, 70, 80, 90, 95, and at the end point. If the liquid temperature reaches 400 °C, or if the vapor reaches a maximum temperature before the end point is observed, record the vapor temperature reading and the total volume recovered at the time the distillation is discontinued. When a product is tested for conformity with a given specification, record all requested observations, whether or not they are listed above.

NOTE 6—The maximum vapor temperature will result either from complete distillation of the oil or from the onset of cracking.

10.10 If a sudden increase in pressure is observed, coupled with the formation of white vapors and a drop in the vapor temperature, the material being distilled is showing significant cracking. Discontinue the distillation immediately and record the fact on the run sheet. If necessary, rerun the distillation with a fresh sample at lower operating pressure.

10.11 Lower the flask heater 5 cm to 10 cm and cool the flask and heater with a gentle stream of air or, preferably, with a stream of carbon dioxide ([Note 7](#)). Repressure the contents of the still with dry nitrogen (~~Warning—Warning~~—Repressuring the contents of the still with air while it contains hot oil vapors can result in fire or explosion.) if it is necessary to dismantle the apparatus before it has cooled below 200 °C. Carbon dioxide can also be used for repressuring, provided liquid nitrogen traps are not in use. (~~Warning—Warning~~—In addition to other precautions, it is recommended to discontinue the distillation at a maximum vapor temperature of 350 °C. Operating the distillation flask at temperatures above 350 °C for prolonged periods at pressures below 1 kPa may also result in thermal deformation of the flask. In this case, discard the flask after use. Alternatively, use a quartz flask.)

NOTE 7—A gentle stream of carbon dioxide is preferred to cool the flask to prevent fire in the event the flask cracks during the test or during the cooling cycle.

10.12 Bring the temperature of the cold trap mounted before the vacuum source back to ambient temperature. Recover, measure, and record the volume of the light products collected in the trap.

10.13 Remove the receiver, empty it, and place it back into the instrument for the cleaning cycle, or use a separate, empty receiver. Remove the flask and replace with a flask filled with a cleaning solvent ([Note 8](#)). Run a distillation at atmospheric pressure to clean the unit. At the end of this cleaning run, remove the flask and receiver and blow a gentle stream of air or nitrogen to dry the unit.

NOTE 8—Toluene or cyclohexane can be used as cleaning solvent.

11. Calculations and Report

11.1 Convert the recorded vapor temperature readings to Atmospheric Equivalent Temperatures (AET) using the equations in [Annex A7](#).

11.2 Report the AET to the nearest degree Celsius corresponding to the volumetric percentages of liquid recovered in the receiver. Report also the identity of the sample, the density (measured in [8.3](#)), the total amount of liquid distillate recovered in the receiver and receiver, in the cold trap before the vacuum source, any unusual occurrence such as foaming or burping, together with the measures that were taken to correct the problem.