



Designation: **F838 – 15a F838 – 15a^{ε1}**

Standard Test Method for Determining Bacterial Retention of Membrane Filters Utilized for Liquid Filtration¹

This standard is issued under the fixed designation F838; the number immediately following the designation indicates the year of original adoption or, in the case of revision, the year of last revision. A number in parentheses indicates the year of last reapproval. A superscript epsilon (ϵ) indicates an editorial change since the last revision or reapproval.

NOTE—Fig. 1 was editorially updated and the year date changed on Sept. 30, 2015.

^{ε1} NOTE—9.1 was editorially corrected in August 2018.

1. Scope

1.1 This test method determines the bacterial retention characteristics of membrane filters for liquid filtration using *Brevundimonas diminuta* as the challenge organism. This test method may be employed to evaluate any membrane filter system used for liquid sterilization.

1.2 This test method is not intended to be used in performance of product- and process-specific validation of the bacterial retention characteristics of membrane filters to be used in pharmaceutical or biopharmaceutical sterilizing filtration, or both. Process- and product-specific bacterial retention validation should be carried out using the intended product manufacturing process parameters and the product solution or surrogate as the carrier fluid.

1.3 The values stated in SI units are to be regarded as standard.

1.3.1 *Exception*—The inch-pound values given for units of pressure are to be regarded as standard; SI unit conversions are shown in parentheses.

1.4 *This standard may involve hazardous materials, operations, and equipment. This standard does not purport to address all of the safety concerns, if any, associated with its use. It is the responsibility of the user of this standard to establish appropriate safety, health, and environmental practices and determine the applicability of regulatory limitations prior to use.*

1.5 *This international standard was developed in accordance with internationally recognized principles on standardization established in the Decision on Principles for the Development of International Standards, Guides and Recommendations issued by the World Trade Organization Technical Barriers to Trade (TBT) Committee.*

2. Referenced Documents

2.1 *ASTM Standards:*²

D1193 Specification for Reagent Water

3. Terminology

3.1 *Definitions:*

3.1.1 *log reduction value*—the logarithm to the base 10 of the ratio of the number of microorganisms in the challenge to the number of organisms in the filtrate.

4. Summary of Test Method

4.1 After sterilization, the test filter is challenged with a suspension of *B. diminuta* (ATCC 19146³) at a concentration of 10^7 organisms per cm^2 of effective filtration area (EFA) at a maximum differential pressure across the test filter of 30 psig (206 kPa) and a flow rate of 2 to 4×10^{-3} LPM per cm^2 of effective filtration area. The entire filtrate is then filtered through an analytical

¹ This test method is under the jurisdiction of ASTM Committee E55 on Manufacture of Pharmaceutical and Biopharmaceutical Products and is the direct responsibility of Subcommittee E55.03 on General Pharmaceutical Standards.

Current edition approved Sept. 30, 2015. Published October 2015. Originally approved in 1983. Last previous edition published in 2015 as F838 – 15. DOI: 10.1520/F0838-15A.10.1520/F0838-15AE01.

² For referenced ASTM standards, visit the ASTM website, www.astm.org, or contact ASTM Customer Service at service@astm.org. For *Annual Book of ASTM Standards* volume information, refer to the standard's Document Summary page on the ASTM website.

³ Available from American Type Culture Collection (ATCC), 10801 University Boulevard, Manassas, VA 20110, http://www.atcc.org.

membrane filter disc, which is subsequently incubated on a solidified growth medium. Microorganisms that are not retained by the filter being tested will develop into visible colonies on the analysis membrane and can then be enumerated.

5. Significance and Use

5.1 This test method is designed to assess the retentivity of a sterilizing filter under standard challenge conditions.

5.1.1 A challenge of 10^7 bacteria per cm^2 of effective filtration area is selected to provide a high degree of assurance that the filter will be challenged uniformly across the membrane surface to assure it will quantitatively retain large numbers of organisms. The model challenge organism, *B. diminuta*, is widely considered to be a small bacterium and is recognized as an industry standard for qualifying sterilizing filters. Other species may represent a worst-case test in terms of ability to penetrate a filter. This test does not provide assurance that filters can completely retain such bacteria.

5.1.2 The analytical procedure utilized in this test method provides a method to assign a numerical value to the filtration efficiency of the filter being evaluated under standard filtration conditions. For the purpose of product sterility assurance, additional process-specific studies should be performed.

6. Apparatus

6.1 Assemble the apparatus described below as in Fig. 1:

6.1.1 *Stainless Steel Pressure Vessel*, 12-L capacity (or larger), fitted with a 0 to 50-psi (0 to 350-kPa) pressure gauge.

6.1.2 *Air Regulator*.

6.1.3 *47-mm–142-mm Analysis Disc Filter Assemblies*, two or more, with hose or sanitary connections as applicable.

6.1.4 *Diaphragm-Protected 0 to 50-psi (0 to 350-kPa) Pressure Gauge*, for upstream pressure reading.

6.1.5 *Manifold*, with valves (autoclavable) and hose connections.

6.1.6 *Autoclavable Tubing*, (must be able to withstand a pressure of 50 psi (350 kPa)).

6.1.7 *Filter Housing*, with hose connections.

6.1.8 *Hose Clamps*.

6.1.9 *Incubator*, $30 \pm 2^\circ\text{C}$.

6.1.10 *Laminar Flow Bench*.

6.1.11 *Smooth-Tip Forceps*.

6.1.12 *Test Filter*.

7. Purity of Reagents and Materials

7.1 *Purity of Reagents*—Reagent grade chemicals shall be used. Unless otherwise indicated, all reagents shall conform to the specifications of the American Chemical Society, where such specifications are available.⁴

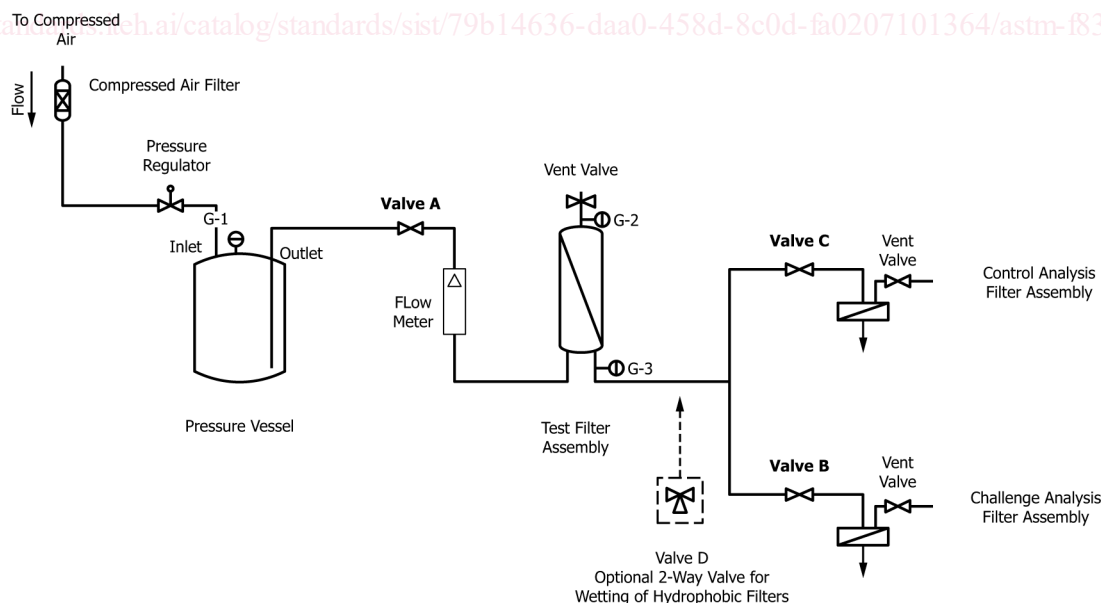

FIG. 1 Test Set-Up for Bacteria Retention Testing

⁴ *Reagent Chemicals, American Chemical Society Specifications*, American Chemical Society, Washington, DC, www.chemistry.org. For suggestions on the testing of reagents not listed by the American Chemical Society, see *Analar Standards for Laboratory Chemicals*, BDH Ltd., Poole, Dorset, U.K., and the *United States Pharmacopoeia and National Formulary*, U.S. Pharmacopoeial Convention, Inc. (USPC), Rockville, MD, <http://www.usp.org>.

7.2 *Purity of Water*—Unless otherwise indicated, references to water shall mean reagent water, Type IV as defined in Specification **D1193**.

7.2.1 Additionally, any water used in this test method must conform to the requirements for non-bacteriostatic water specified in the current edition of *Standard Methods for the Examination of Water and Wastewater*.⁵

8. Reagents and Materials

8.1 Saline Lactose Broth Medium:

8.1.1 *Lactose Broth*—Dissolve 1.3 g of dehydrated lactose broth medium in 100 mL of water.

8.1.2 *Sodium Chloride Solution*—Dissolve 7.6 g of sodium chloride (NaCl) in 970 mL of water in a 2-L flask with an appropriate closure.

8.1.3 Add 30 mL of lactose broth (8.1.1) to 970 mL of sodium chloride solution. Autoclave at 121°C for 15 min.

8.2 Frozen Cell Paste Method:

8.2.1 *Growth Medium A*—Dissolve in water and dilute to 1 L. Autoclave at 121°C for 15 min (pH 6.8 to 7.0).

Tryptic Peptone (or Casitone)	7.5 g
Yeast Extract	2.5 g
Sodium Chloride (NaCl)	0.5 g
Magnesium Sulfate (MgSO ₄ ·3H ₂ O)	0.35 g

8.2.2 *Harvesting Buffer*—Dissolve 0.790 g of monobasic potassium phosphate (KH₂PO₄) and 1.0 g of K₂HPO₄ in 100 mL of glycerol (C₃H₈O₃). Adjust to pH 7.2 with 0.1 N potassium hydroxide solution. Dilute to 1 L with water and sterilize at 121°C for 15 min.

8.2.3 *Potassium Hydroxide Solution (0.1 N)*—Dissolve 5.61 g of potassium hydroxide (KOH) in water and dilute to 1 L in a volumetric flask.

8.2.4 *Tryptic Soy Agar*—Prepare according to manufacturer's instructions.

8.2.5 *Tryptic Soy Broth*—Prepare according to manufacturer's instructions.

8.3 Analytical Reagents and Materials:

8.3.1 *M-Plate Count Agar*—Prepare according to manufacturer's instructions.

8.3.2 *Peptone Water (1 g/L)*—Dissolve the peptone in water. Dispense suitable volumes, for preparing decimal dilutions, into screw-cap containers. Autoclave at 121°C for 15 min.

8.4 *B. diminuta* (ATCC 19146).

8.5 *Analytical Membrane Filters*, 47-mm or 142-mm diameter, 0.45 µm pore size, 130 to 160 µm thick.

8.6 *Petri Dishes*, 150-mm diameter.

9. Methods for Preparation of Bacterial Challenge Stock Suspension

9.1 *General*—The following two methods have been used extensively for the preparation of *B. diminuta* challenge suspensions. The presentation of these methods is not meant to exclude other equally valid methods for the preparation of *B. diminuta*. It is important, however, that any *BPB. diminuta* challenge suspension used is monodisperse and meets the criteria set forth in Section 10.

9.2 Reconstitute the culture according to directions provided by the American Type Culture Collection (ATCC). Check the purity of the reconstituted culture by means of streak plates. Examine for uniform colony morphology, and identify single-cell isolates as *B. diminuta* in accordance with Section 10.

9.2.1 *Stock Cultures*—Prepare stock cultures from single cell isolates of 9.2. Inoculate tryptic soy agar slants and incubate at 30 ± 2°C for 24 h. Overlay slants with sterile mineral oil and store at 4°C. Check weekly for viability and purity. Alternatively, tryptic soy semisolid agar stab cultures may be substituted for the slant cultures.

9.2.2 *Long Term Storage of Cultures*—Lyophilize or store in liquid nitrogen.

9.3 Preparation of Challenge Stock Suspension in Saline Lactose Broth:

9.3.1 Inoculate 10-mL sterile tryptic soy broth with stock culture (9.2.1) and incubate at 30 ± 2°C for 24 h.

9.3.2 Transfer 2 mL of agitated broth culture to 1 L of sterile saline lactose broth, swirl to mix inoculum and incubate at 30 ± 2°C for 24 h. Check purity of seed broth.

NOTE 1—Saline lactose broth suspension may be stored at 4°C for up to 8 h prior to use.

9.3.3 Determine the concentration of viable cells in the challenge suspension according to Section 11 (expected concentration is 10⁷ to 10⁸ cells/mL).

9.3.4 Identify the organisms as *B. diminuta* in accordance with Section 10.

9.4 Preparation of Frozen Cell Paste of *B. diminuta*:

⁵ Available from the American Public Health Association (APHA), 800 I Street, NW, Washington, DC 20001-3710, <http://www.apha.org>.

9.4.1 Inoculate 10 mL of Sterile Growth Medium A (8.2.1) with the stock culture (9.2.1) and incubate at 30 ± 2°C for 24 h.

9.4.2 Transfer 10 mL of the bacterial suspension from 9.3.1 into 500 mL of Sterile Growth Medium A and incubate at 30 ± 2°C for 24 h.

9.4.3 Prepare 10 L of a seed culture by transferring 200 mL of the bacterial suspension from 9.4.2 into 10 L of Sterile Growth Medium A. Incubate at 30 ± 2°C for 24 h.

9.4.4 Inoculate the 10 L of the seed culture into 500 L of Growth Medium A. Grow aerobically at 30 ± 2°C. Monitor growth spectrophotometrically at 500 nm, and plot growth curve.

9.4.5 When the culture reaches the stationary phase, harvest the cells by continuous flow centrifugation.

9.4.6 Re-suspend cells in two to three volumes of cold sterile harvesting buffer.

9.4.7 Centrifuge suspension and re-suspend cells in an equal volume of harvesting buffer. Determine the cell concentration (expected concentration of viable cells is 1 × 10¹² cells/mL).

9.4.8 Transfer aliquots (for example, 50 mL) of cell paste into sterile plastic centrifuge tubes, and freeze using dry ice-acetone batch or liquid nitrogen. Store frozen cell paste at –70°C.

9.5 Preparation of Challenge Stock Suspension from Frozen Cell Paste:

9.5.1 Disinfect the tube containing the cell paste by dipping tube in 80 % ethyl alcohol and flaming just long enough to burn off most of the alcohol. Use sterile tongs to hold tube.

9.5.2 Aseptically remove the cap from the tube and drop the tube into a sterile Erlenmeyer flask containing a sterile magnetic stirring bar and 20 cell volumes of a sterile solution of 0.9 % NaCl which contains 0.001 to 0.002 M MgCl₂ at room temperature (for example, transfer a 50-mL aliquot of frozen cell paste into 1 L of sterile solution).

NOTE 2—MgCl₂ must be in the solution prior to adding the frozen cell paste to prevent dumping during thaw.

9.5.3 Place the flask on a magnetic stirring unit, and mix until the entire contents of the tube is suspended evenly (about 40 min).

9.5.4 Determine the concentration of viable cells according to Section 11 (expected concentration of the cell suspension is 1 to 2 × 10¹⁰ cells/mL).

9.5.5 Identify the organism as *B. diminuta* in accordance with Section 10.

10. Identification of *B. diminuta*

10.1 Colonial Morphology:

10.1.1 Colonies of *B. diminuta* are yellow-beige, slightly convex, complete and shiny.

10.1.2 At 30°C (optimum growth temperature) colonies are microscopic to pinpoint after 24 h and 1 to 2-mm diameter after 36 to 48 h.

10.2 Microscopic Examination:

10.2.1 Prepare a Gram stain.

10.2.1.1 Examine the preparation with a compound light microscope fitted with a calibrated ocular micrometer and an oil immersion objective lens with good resolving power (for example, a planachromatic objective with a numerical aperture of 1.2 or greater). Observe several microscopic fields for organisms' size and arrangement of cells.

10.2.1.2 Stained preparations should reveal a Gram-negative, small, rod-shaped organism about 0.3 to 0.4 µm by 0.6 to 1.0 µm in size, occurring primarily as single cells.

10.2.2 Prepare a flagella stain (optional). *B. diminuta* is characterized by a single, polar flagellum.

10.3 Biochemical Characterization:

10.3.1 Perform a number of the following biochemical characterization tests. *B. diminuta* gives the results indicated:⁶

Test	<i>B. diminuta</i> (ATCC 19146)
Spore formation	–
OF glucose medium, open	–
OF glucose medium, sealed	–
OF ethanol (3 %) medium, open	+
OF ethanol (3 %) medium, sealed	–
Indole	–
Methyl red	–
Acetylmethylcarbionol	–
Gelatinase	–
Aerobe	+
Catalase	+
Cytochrome (Indophenol) oxidase	+
Growth on MacConkey agar	+
Denitrification	+

⁶ Confirmation of the identity of *B. diminuta* may also be achieved using molecular-based or other qualified methods (for example, 16S rRNA Sequencing, FAME).