



Designation: ~~D3744/D3744M~~ – 11a D3744/D3744M – 18

## Standard Test Method for Aggregate Durability Index<sup>1</sup>

This standard is issued under the fixed designation D3744/D3744M; the number immediately following the designation indicates the year of original adoption or, in the case of revision, the year of last revision. A number in parentheses indicates the year of last reappraisal. A superscript epsilon ( $\epsilon$ ) indicates an editorial change since the last revision or reappraisal.

### 1. Scope

1.1 This test method covers the determination of a durability index of an aggregate. The calculated durability index is a value indicating the relative resistance of an aggregate to production of detrimental clay-like fines when subjected to the prescribed mechanical methods of degradation.

1.2 *Units*—The values stated in either SI units or inch-pound units are to be regarded separately as standard. The values stated in each system may not be exact equivalents; therefore, each system shall be used independently of the other. Combining values from the two systems may result in ~~non-conformance~~nonconformance with the standard.

1.2.1 Measurements of volume and mass are only given in SI units because they are the only units typically used in practice when performing this test method.

1.2.2 Measurements in Section 11, Section 15, ~~Eq 3~~Equation 3, ~~Eq 4~~Equation 4, Table 1, and ~~Figure 2~~and Table 1 are only given in inch-pound units because the equipment used in these sections is only manufactured using the inch-pound system.

1.3 *This standard does not purport to address all of the safety concerns, if any, associated with its use. It is the responsibility of the user of this standard to establish appropriate safety, health, and ~~health~~environmental practices and determine the applicability of regulatory limitations prior to use.*

1.4 *This international standard was developed in accordance with internationally recognized principles on standardization established in the Decision on Principles for the Development of International Standards, Guides and Recommendations issued by the World Trade Organization Technical Barriers to Trade (TBT) Committee.*

### 2. Referenced Documents

2.1 *ASTM Standards:*<sup>2</sup>

~~C127~~ C127 Test Method for Relative Density (Specific Gravity) and Absorption of Coarse Aggregate

~~C136~~ C136 Test Method for Sieve Analysis of Fine and Coarse Aggregates

~~C702~~ C702 Practice for Reducing Samples of Aggregate to Testing Size

~~D75~~ D75 Practice for Sampling Aggregates

~~D2419~~ D2419 Test Method for Sand Equivalent Value of Soils and Fine Aggregate

~~D3666~~ D3666 Specification for Minimum Requirements for Agencies Testing and Inspecting Road and Paving Materials

~~D4753~~ D4753 Guide for Evaluating, Selecting, and Specifying Balances and Standard Masses for Use in Soil, Rock, and Construction Materials Testing

~~E11~~ E11 Specification for Woven Wire Test Sieve Cloth and Test Sieves

### 3. Summary of Test Method

3.1 This test method was developed to permit prequalification of aggregates proposed for use in the construction of transportation facilities. ~~Basically, the~~ This test establishes an aggregate's resistance to generating fines when agitated in the presence of water. Separate and different test procedures are used to evaluate the coarse and the fine portions of ~~a material an~~ an aggregate.

3.2 A sample of coarse aggregate is prepared to a specific grading and then washed in a ~~mechanical~~ washing vessel for a ~~2-min~~ agitation time. ~~secured in a mechanical agitator for 2 min.~~ After discarding the minus 4.75-mm (No. 4) material, dry the washed test sample.

<sup>1</sup> This test method is under the jurisdiction of ASTM Committee D04 on Road and Paving Materials and is the direct responsibility of Subcommittee D04.51 on Aggregate Tests.

Current edition approved Dec. 1, 2018. Published December 2018. Originally approved in 1979. Last previous edition approved in 2011 as ~~D3744-11~~ D3744/D3744M-11a. DOI: ~~10.1520/D3744-D3744M-11A~~ 10.1520/D3744\_D3744M-18.

<sup>2</sup> For referenced ASTM standards, visit the ASTM website, www.astm.org, or contact ASTM Customer Service at service@astm.org. For *Annual Book of ASTM Standards* volume information, refer to the standard's Document Summary page on the ASTM website.

3.3 The coarse aggregate test sample is then mechanically agitated in the ~~mechanical~~-washing vessel for a period of 10 min. A representative portion of the resulting wash water and minus 75- $\mu\text{m}$  (No. 200) size fines is collected and mixed with a stock calcium chloride solution and placed in a plastic cylinder. After a 20-min sedimentation time, the level of the sediment column is read. The height of the sediment value is then used to calculate the durability index of the coarse aggregate ( $D_{cc}$ ).

3.4 The fine aggregate sample is prepared by washing a specific quantity of the material in the ~~mechanical~~-washing vessel for a ~~2-min agitation period, secured in a mechanical agitator for 2 min.~~ All minus 75- $\mu\text{m}$  (No. 200) size material is washed from the sample through a 75- $\mu\text{m}$  (No. 200) sieve and discarded. The plus 75- $\mu\text{m}$  (No. 200) fraction is dried.

3.5 The fine aggregate test sample is tested by the ~~Standard Sand Equivalent Test Method~~ standard sand equivalent test method (Test Method **D2419**) except for modifications to the test sample preparation and duration of the shaking time. The mechanical shaker method is required. A shaking time of 10 min instead of 45 s is used.

3.6 This test method includes procedures for testing aggregates exhibiting a wide range in specific gravity, including lightweight and porous coarse aggregates, and also procedures for testing small ~~maximum size~~ maximum-size aggregate which is too fine to test as a coarse aggregate and too coarse to consider as a fine aggregate, such as a pea gravel or a very coarse sand.

3.7 The durability index for coarse aggregate ( $D_{cc}$ ) or for fine aggregate ( $D_{ff}$ ) is calculated, as applicable, by appropriate equations presented in the method. The durability index of a well-graded aggregate containing both coarse and fine fractions is defined as the lowest of the two values,  $D_{cc}$  or  $D_{ff}$ , obtained by the test. This value is recommended to be the controlling value for specification purposes.

#### 4. Significance and Use

4.1 This test method assigns an empirical value to the relative amount, fineness, and character of clay-like material that may be generated in an aggregate when subjected to mechanical degradation.

4.2 The procedure has been used in limited geographical areas of the United States, and the results have been correlated with aggregate performance in various construction applications, including: aggregate base, permeable material for backfill, fine concrete aggregate, and riprap for rock slope protection.<sup>3,4</sup>

4.3 A minimum durability index is permitted to be specified to prohibit the use of an aggregate in various construction applications that is prone to degradation, resulting in generation of clay-like fines.

4.4 This test method provides a rapid test for evaluation of the quality of a new aggregate source. Research has indicated it may also be suitable for use instead of the sodium sulfate soundness test for evaluating the durability characteristics of fine aggregate for use in ~~portland-cement~~ portland cement concrete, thereby reducing the need for time-consuming and expensive soundness tests.<sup>3</sup>

4.5 Although the application of this method has been limited to aggregates for specific construction uses, the possibility exists for expanding the application of this method to control the quality of aggregates used in other areas of construction, such as aggregates for use in bituminous paving mixtures, coarse aggregate for use in ~~portland-cement~~ portland cement concrete, and aggregate for use as railroad ballast.

NOTE 1—The text of this test method references notes and footnotes which provide explanatory material. These notes and footnotes (excluding those in tables and figures) shall not be considered as requirements of the test method.

NOTE 2—The quality of the results produced by this standard are dependent on the competence of the personnel performing the procedure and the capability, calibration, and maintenance of the equipment used. Agencies that meet the criteria of Practice Specification D3666 are generally considered capable of competent and objective ~~testing/sampling/inspection/etc.~~ testing, sampling, inspection, etc. Users of this standard are cautioned that compliance with Practice Specification D3666 alone does not completely ~~assure~~ ensure reliable results. Reliable results depend on many factors; following the suggestions of Practice Specification D3666 or some similar acceptable guideline provides a means of evaluating and controlling some of those factors.

#### 5. Apparatus

5.1 *Mechanical-Washing Vessel or Wash Vessel (Pot)*—A flat-bottomed, straight-sided cylindrical vessel similar to the design shown in Fig. 1, with a volume of approximately 7 liters and inner diameter of approximately 200 mm [8 in.]. The vessel lid must be equipped with a rubber gasket or another means of preventing leaks during agitation.

5.2 *Collection Pan*—A round pan (at least 230 mm [9 in.] in diameter and approximately 100 mm [4 in.] deep), suitable to collect the wash water from the washed sample. The pan shall have vertical or nearly vertical sides and shall be equipped as necessary to hold the wire mesh of a 200-mm [8-in.] diameter sieve at least 75 mm [3 in.] above the bottom. An adaptor that will not allow loss of fines or wash water may be used to nest the sieve with the container, or the sieve may be nested with a blank sieve frame resting in the bottom of the pan.

<sup>3</sup> Hamilton, R. D., Smith, R. E., and Sherman, G. B., "Factors Influencing the Durability of Aggregates," Research Report 633476, State of California, Division of Highways, Materials and Research Department, June 1971.

<sup>4</sup> Hveem, F. N., and Smith, T. N., "Durability of Aggregates," Research Report, State of California, Division of Highways, Materials and Research Department, January 1964.

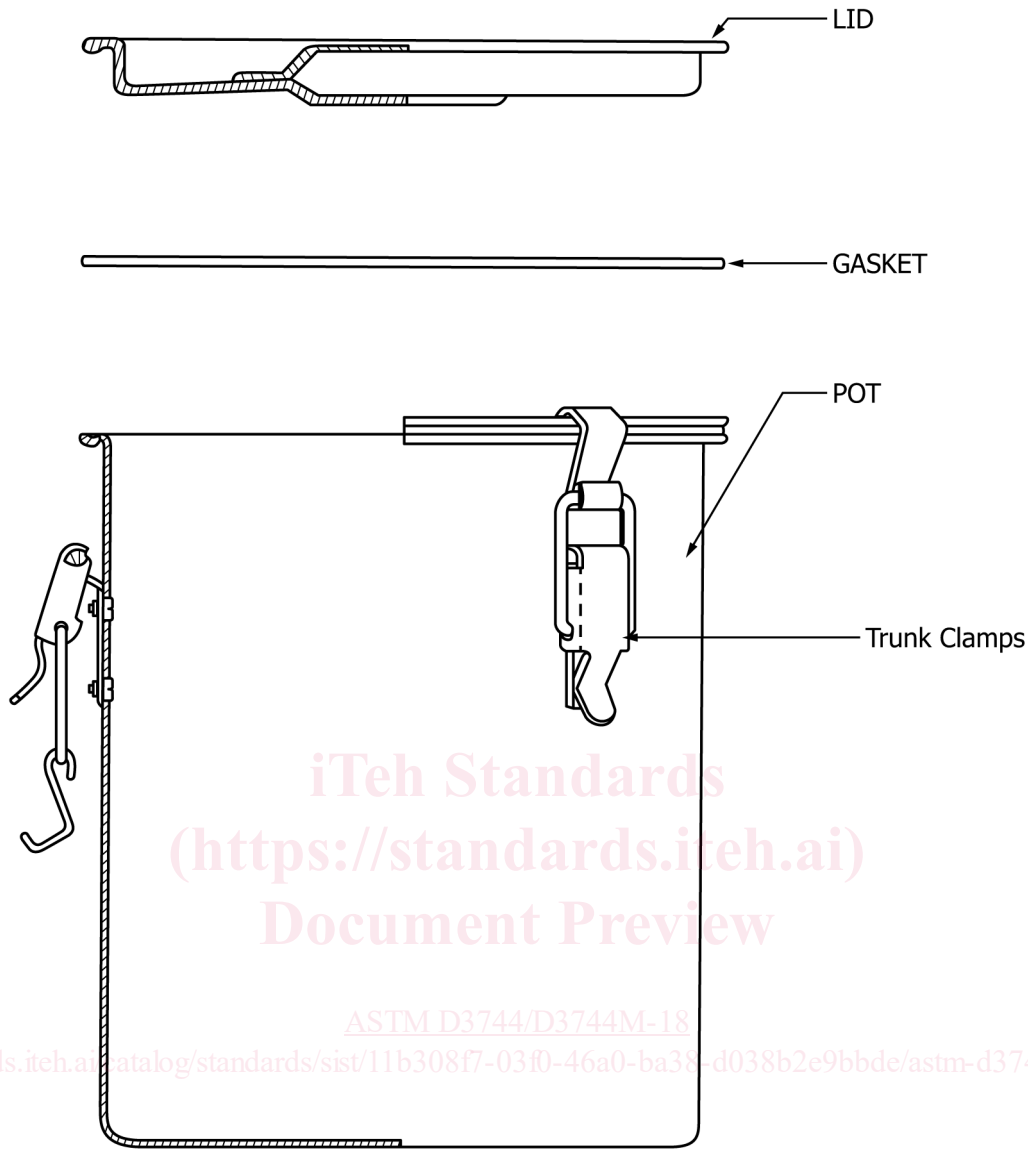

FIG. 1 Mechanical-Washing Vessel (Wash Vessel)

5.3 *Mechanical Agitator*—A mechanical device designed to hold the wash vessel in an upright position while subjecting it to a lateral reciprocating motion of  $45 \pm 6$  mm [ $1\frac{3}{4} \pm \frac{1}{4}$  in.] at a rate of  $285 \pm 10$  complete cycles per minute. Fig. 2 See Note 3 shows a Tyler portable sieve shaker modified to meet these requirements.

NOTE 3—The Tyler portable shaker previously referenced and requiring modifications hasn't been manufactured since 1986. Further, it was a manufactured sieve shaker that required each customer to modify the equipment from its original design to meet the lateral reciprocating requirements listed in 5.3. While it is possible some modified Tyler shakers are still in use today, there are other manufactured agitators that do not require customer modifications to meet the lateral reciprocating requirements listed in 5.3.

5.4 All equipment required to perform the Test for Sand Equivalent Value of Soils and Fine Aggregates and equivalent value of soils and fine aggregate (Test Method D2419).

5.5 *Sieves*—The sieves shall conform to Specification E11.

5.6 *Balance*—A balance having a minimum capacity of 500 g 500 g and meeting the requirements of Guide D4753, Class GP5.

5.7 *Oven*—An oven capable of maintaining a temperature of  $110 \pm 5^\circ\text{C}$  [ $230 \pm 10^\circ\text{F}$ ].

5.8 *Graduated Cylinder*—A 1000-mL graduated cylinder.

5.9 *Funnel*—A funnel of sufficient size to allow for transfer of wash water from the collection pan to the graduated cylinder.

**6. Reagents and Materials**

6.1 *Calcium Chloride Solutions*—Use stock and working calcium chloride solutions as specified in the Reagents and Materials section of Test Method **D2419**.

6.2 *Water*—Use distilled or demineralized water for the normal performance of this test method. The test results are likely to be affected by certain minerals dissolved in water. However, if it is determined that local tap water is of such purity that it does not affect the test results, the use of tap water is permissible in place of distilled or demineralized water. For referee purposes, distilled or demineralized water shall be used for all steps in the test.

**7. Temperature Control**

7.1 This test method is normally performed without strict temperature control; however, for referee purposes, retest the material with the temperature of the distilled or demineralized water and the working calcium chloride solution at  $22 \pm 3^\circ\text{C}$  [ $72 \pm 5^\circ\text{F}$ ].

**8. Sampling**

8.1 Obtain samples of the aggregate to be tested in accordance with Practice **D75D75/D75M**.

**9. Initial Sample Preparation**

9.1 Dry aggregate samples sufficiently to permit a complete separation on the 4.75-mm (No. 4) sieve and to develop a free-flowing condition in the portion passing the sieve. Perform drying by any method that does not heat the aggregate in excess of  $60^\circ\text{C}$  [ $140^\circ\text{F}$ ] or cause degradation of the particles. Sunlight, ovens, or forced drafts of warm air are the most commonly used sources of heat.

9.2 If the sample contains an appreciable amount of clay, turn the aggregate frequently during the drying process to obtain even drying throughout and to prevent the formation of hard clay lumps.

9.3 Break up any hard clods and remove coatings of fines from the coarse aggregate particles by any means that will not appreciably reduce the natural individual particle sizes.

9.4 Determine the sample grading by sieving in accordance with Test Method **C136C136/C136M** on 19.0, 12.5, 9.5, 4.75, 2.36, and 1.18-mm ( $\frac{3}{4}$ ,  $\frac{1}{2}$ , and  $\frac{3}{8}$ -in. and Nos. 4, 8, and 16) sieves. Discard any material that is retained on the 19.0-mm ( $\frac{3}{4}$ -in.) sieve.

9.5 Determine the test procedures to be used for establishing the durability index of the aggregate based upon the grading of the aggregate as determined in 9.4.

9.5.1 If less than 10 % of the aggregate passes the 4.75-mm (No. 4) sieve, test coarse aggregate (Procedure A) only.

9.5.2 If less than 10 % of the aggregate is coarser than the 4.75-mm (No. 4) sieve, test fine aggregate (Procedure B) only.

9.5.3 When both coarse and fine aggregate fractions are each present in quantities equal to or greater than 10 % and if the percent passing the 1.18-mm (No. 16) sieve is greater than 10 %, use both Procedures A and B on the appropriate aggregate sizes. If the percent passing the 1.18-mm (No. 16) sieve is less than or equal to 10 %, use Procedure A or Procedure C.

9.5.4 If most of the aggregate (75 to 80 %) is retained between the 9.5 and 1.18-mm ( $\frac{3}{8}$ -in. and No. 16) sieves, use Procedure C only.

~~**PROCEDURE A—COARSE AGGREGATE**~~

**PROCEDURE A – COARSE AGGREGATE**

**10. Test Sample Preparation**

10.1 Prepare a  $2550 \pm 25$ -g (air-dry) preliminary test sample using the grading given below:

Aggregate Size	Air-Dry Mass, g
Aggregate Size	Air-Dry Mass, g
19.0 to 12.5 mm ( $\frac{3}{4}$ to $\frac{1}{2}$ in.)	1070 $\pm$ 10
12.5 to 9.5 mm ( $\frac{1}{2}$ to $\frac{3}{8}$ in.)	570 $\pm$ 10
9.5 to 4.75 mm ( $\frac{3}{8}$ in. to No. 4)	910 $\pm$ 5
	2550 $\pm$ 25

For materials with less than 10 % in any of the size fractions given in 10.1, prepare the test sample using the actual percentage for the deficient fraction and proportionally increase the mass of the remaining fractions to obtain the  $2550 \pm 25$ -g test sample. Two examples follow.

Example 1—Less than 10 % in 19.0 to 12.5 mm ( $\frac{3}{4}$  to  $\frac{1}{2}$  in.) fraction

Aggregate Size	Percent	Calculation	Air-Dry Mass, g
Aggregate Size	Percent	Calculation	Air-Dry Mass, g
19.0 to 12.5 mm ( $\frac{3}{4}$ to $\frac{1}{2}$ in.)	6	$0.06 \times 2550$	153 $\pm$ 10
12.5 to 9.5 mm ( $\frac{1}{2}$ to $\frac{3}{8}$ in.)	26	$570 (2550 - 153)$	923 $\pm$ 10
		$570 + 910$	



9.5 to 4.75 mm (¾ to No. 4)	68	$\frac{910 (2550 - 153)}{570 + 910}$	1474 ± 5
Totals	100		2550 ± 25

Example 2—Less than 10 % in two fractions

Aggregate-Size	Percent	Calculation	Air-Dry Mass, g
Aggregate Size	Percent	Calculation	Air-Dry Mass, g
19.0 to 12.5 mm (¾ to ½ in.)	4	0.04 × 2550	102 ± 10
12.5 to 9.5 mm (½ to ⅜ in.)	7	0.07 × 2550	179 ± 10
9.5 to 4.75 mm (¾ to No. 4)	89	2550 - (102 + 179)	2269 ± 5
Totals	100		2550 ± 25

10.2 Place the preliminary test sample in the ~~mechanical~~-washing vessel and add 1000 ± 5 mL of distilled or demineralized water.

10.3 Because of the low specific gravity or high absorption rate, or both, of some aggregates, the proportions of aggregate to water will not provide the intended interparticle abrasion. Testing of these materials will require adjustment of the test specimen mass or volume of both wash and test water, or both.

10.3.1 Wash all materials that are not completely inundated when 1000 mL of water ~~are~~ added to the test sample and test with adjusted sample masses and water volumes.

10.3.2 Determine the bulk, oven-dry specific gravity, and percentage of absorption of the aggregate in accordance with Test Method C127.

10.3.3 Adjust the total mass of the test sample using the following equation:

$$\text{Adjusted sample mass, g} = \frac{\text{specific gravity of aggregate}}{2.65} \times W \tag{1}$$

where:

W = mass of oven-dried test sample, g.

Adjust the mass of material in each size fraction proportionally to the masses specified in 10.1.

10.3.4 Adjust the volume of test water using the following equation:

$$\text{Adjusted water} = 1000 + (A \times W) - 50 \tag{2}$$

where:

A = absorption of aggregate, % (expressed as a decimal fraction), and

W = mass of oven-dried test sample, g.

10.4 Clamp the vessel lid in place, on the wash vessel and secure the vessel in the ~~sieve shaker~~-mechanical agitator. Begin agitation after a time of ~~60-1 min~~ (60 ± 10 s) has elapsed from the introduction of the wash water. Agitate the wash vessel in the ~~sieve shaker~~ for ~~120- mechanical agitator~~ for 2 min (120 ± 5 s).

10.5 After the 2-min (120 ± 5 s) agitation time is completed, remove the washing vessel from the ~~shaker~~-mechanical agitator, unclamp the lid, and pour the contents onto a 4.75-mm (No. 4) sieve. Rinse any remaining fines from the wash vessel onto the sieve and direct water (from a flexible hose attached to a faucet) onto the aggregate until the water passing through the sieve comes out clear.

10.6 Dry the fraction retained on the 4.75-mm (No. 4) sieve to constant mass at a temperature of 110 ± 5°C [230 ± 10°F] and weigh. Calculate the loss in mass due to washing in accordance with 10.2, 10.3, 10.4, and 10.5. If it's equal to or less than 75 g, a test sample suitable for further testing has been prepared and the procedures in 10.7 – 10.12 are omitted. If the loss in mass exceeds 75 g, the preliminary test sample is permitted to be retained and used if a second sample is washed by the same procedure and the two samples are combined according to the specified masses to provide the desired test sample.

10.7 Determine the grading to be used in preparing the preliminary test sample as follows:

10.7.1 If each of the aggregate sizes listed in the following table represents 10 % or more of the 19.0-mm to 4.75-mm (¾-in. to No. 4) portion, as determined from the masses recorded in 9.4, use the oven-dry masses of material specified below for preparing the preliminary test sample.

Aggregate Size	Oven-Dry Mass, g
19.0 to 12.5 mm (¾ to ½ in.)	1050 ± 10
12.5 to 9.5 mm (½ to ⅜ in.)	550 ± 10
9.5 to 4.75 mm (¾ in. to No. 4)	900 ± 5
	<hr/> 2500 ± 25

10.8 Prepare a 2500-g preliminary test sample using the prescribed grading. Dry the test sample to constant mass at a temperature of 110 ± 5°C [230 ± 10°F].



10.9 Mechanically wash the preliminary sample in the same manner as prescribed in 10.2, 10.3, 10.4, and 10.5.

10.10 Repeat 10.8 and 10.9, if necessary, to obtain sufficient material to yield a washed test sample of  $2500 \pm 25$  g and contain each size fraction in the quantity specified in 10.7.1.

10.11 After allowing the oven-dried material to cool, separate the washed coarse aggregate on the 12.5, 9.5, and 4.75-mm ( $\frac{1}{2}$ - and  $\frac{3}{8}$ -in., and No. 4) sieves. Discard the material passing the 4.75-mm (No. 4) sieve.

10.12 Prepare the washed test sample using the masses specified in 10.7.1 from representative portions of each size of washed material. Occasionally, a third preliminary test sample is needed to obtain the required mass of material of a specific size.

## 11. Procedure for Coarse Aggregate

11.1 Place the plastic cylinder (sand equivalent test cylinder as required in Test Method D2419) on a work table which will not be subjected to vibrations during the performance of the sedimentation phase of the test. Pour 7 mL of the stock calcium chloride solution into the cylinder. Place a 4.75-mm and ~~75- $\mu$ m~~ 75- $\mu$ m (Nos. 4 and 200) sieve on the pan or vessel provided to collect the wash water with the ~~4.75-mm~~ 4.75-mm (No. 4) sieve on top. The ~~4.75-mm~~ 4.75-mm (No. 4) sieve serves only to protect the ~~75- $\mu$ m~~ 75- $\mu$ m (No. 200) sieve.

11.2 Place the washed test sample (as prepared in Section 10) in the ~~mechanical~~-washing vessel. Then add the amount of distilled or demineralized water as determined in 10.3, clamp the lid in place, and secure the washing vessel in the ~~sieve shaker~~mechanical agitator. Begin agitation after a period of ~~60 s~~ 1 min ( $60 \pm 10$  s) has elapsed from the introduction of the wash water. ~~Agitate~~ Mechanically agitate the washing vessel for ~~600~~ 10 min ( $600 \pm 15$  s).

11.3 Immediately following the agitation period, take the washing vessel from the ~~sieve shaker~~mechanical agitator and remove the lid. Agitate the contents of the washing vessel by moving the upright vessel vigorously in a horizontal circular motion five or six times in order to bring the fines into suspension. Immediately pour the contents of the washing vessel into the nested 4.75-mm and 75- $\mu$ m (Nos. 4 and 200) sieves placed in the pan provided to collect the wash water. Discard the material retained on the 4.75-mm (No. 4) sieve. Collect all wash water and passing 75- $\mu$ m (No. 200) material in the collecting pan. To ensure that all material finer than the 75- $\mu$ m (No. 200) sieve is washed through the sieve, take the following steps:

11.3.1 As the wash water is draining through the 75- $\mu$ m (No. 200) sieve, apply a jarring action to the sieve by lightly bumping the side of the sieve frame with the heel of the hand.

11.3.2 When a concentration of the material is retained on the 75- $\mu$ m (No. 200) sieve, ~~rerinsere-rinse~~ rerinsere-rinse the fine material by pouring the wash water through the sieve again. To ~~rerinsere-rinse~~ rerinsere-rinse the material:

11.3.2.1 Allow the wash water to stand undisturbed in the collection pan for a few moments to permit the heavier particles to settle to the bottom.

11.3.2.2 Pour the upper portion of the wash water into another container.

11.3.2.3 Pour the wash water back through the 75- $\mu$ m (No. 200) sieve and again collect all wash water and passing 75- $\mu$ m (No. 200) material in the collection pan.

11.3.2.4 Repeat the rinsing procedure as necessary until all of the minus 75- $\mu$ m (No. 200) material has been washed through the sieve.

11.4 Transfer the contents of collection pan into the 1000-mL graduated cylinder. Add distilled or demineralized water to bring the volume of dirty wash water to  $1000 \pm 5$  ~~mL~~ mL. Then transfer the wash water to a vessel suitable for stirring and pouring.

11.5 Place a funnel in the graduated plastic cylinder. Stir the wash water by hand to bring the fines into suspension. While the water is still turbulent, pour enough of the wash water into the cylinder to bring the level of the liquid to the 15-in. mark.

11.6 Remove the funnel, place the stopper in the end of the cylinder, and prepare to mix the contents immediately.

11.7 Mix the contents of the cylinder by alternately turning the cylinder upside down and right side up, allowing the bubble to completely traverse the length of the cylinder 20 times in approximately 35 s.

11.8 At the completion of the mixing process, place the cylinder on the work table and remove the stopper. Allow the cylinder to stand undisturbed for ~~1200~~ 20 min ( $1200 \pm 15$  s). Then immediately read and record the height of the sediment column to the nearest 0.1 in.

NOTE 4—There are two unusual conditions that may be encountered in this phase of the test procedure. One is that a clearly defined line of demarcation may not form between the sediment and the liquid above it in the specified 20-min period. If this should occur in a test in which distilled or demineralized water is used, allow the cylinder to stand undisturbed until the clear demarcation line does ~~form~~ form, then immediately read and record the height of the column of sediment and the total sedimentation time. If this should occur in a test in which tap water is used, discontinue the test and retest using an untested portion of the sample with distilled or demineralized water. The second unusual condition is that the liquid immediately above the line of demarcation may still be darkly clouded at the end of 20 min, and the demarcation line, although distinct, may appear to be in the sediment column itself. As for the first case, if tap water was used, rerun the test using a new sample with distilled or demineralized ~~water~~ water. ~~Otherwise~~, read and record this line of demarcation at the end of the specified 20-min sedimentation period as usual.