



Standard Test Method for High Temperature Foaming Characteristics of Lubricating Oils¹

This standard is issued under the fixed designation D 6082; the number immediately following the designation indicates the year of original adoption or, in the case of revision, the year of last revision. A number in parentheses indicates the year of last reapproval. A superscript epsilon (ϵ) indicates an editorial change since the last revision or reapproval.

1. Scope

1.1 This test method describes the procedure for determining the foaming characteristics of lubricating oils (specifically transmission fluid and motor oil) at 150°C.

1.2 Foaming characteristics of lubricating oils at temperatures up to 93.5°C are determined by Test Method D 892 or IP 146 .

1.3 The values stated in SI units are to be regarded as the standard.

1.4 *This standard does not purport to address all of the safety concerns, if any, associated with its use. It is the responsibility of the user of this standard to establish appropriate safety and health practices and determine the applicability of regulatory limitations prior to use.* For specific hazard statements, see Section 8.

2. Referenced Documents

2.1 ASTM Standards:

D 892 Test Method for Foaming Characteristics of Lubricating Oils²

E 1 Specification for ASTM Thermometers³

E 128 Test Method for Maximum Pore Diameter and Permeability of Rigid Porous Filters for Laboratory Use⁴

2.2 Institute of Petroleum Standards:⁵

IP146 Standard Method of Test for Foaming Characteristics of Lubricating Oils

3. Terminology

3.1 Definitions:

3.1.1 *diffuser, n—for gas*, a device for dispersing gas into a liquid (Test Method D 892).

3.1.1.1 *Discussion*—Although diffusers can be made of either metallic or non-metallic materials, in this test method the diffuser is sintered stainless steel.

3.1.2 *entrained air (or gas), n—in liquids*, a two-phase mixture of air (or gas) dispersed in a liquid in which the liquid is the major component on a volumetric basis.

3.1.2.1 *Discussion*—The air (or gas) is in the form of discrete bubbles of about 10 to 1000 μm in diameter. The bubbles are not uniformly dispersed. In time, they rise to the surface to coalesce to form larger bubbles which break or form foam. Subsurface coalescence can also occur, in which case, the bubbles will rise more rapidly.

3.1.3 *foam, n—in liquids*, a collection of bubbles formed in or on the surface of a liquid in which the air or gas is the major component on a volumetric basis.

3.1.4 *gas, n—a fluid (such as air)* that has neither independent shape nor volume but tends to expand indefinitely.

3.1.5 *lubricant, n—any material* interposed between two surfaces that reduces friction or wear between them.

3.1.5.1 *Discussion*—In this test method, the lubricant is an oil which may or may not contain additives such as foam inhibitors.

3.1.6 *maximum pore diameter, n—in gas diffusion*, the diameter of a capillary of circular cross-section which is equivalent (with respect to surface tension effects) to the largest pore of the diffuser under consideration. The pore dimension is expressed in micrometers (μm).

3.1.7 *permeability, n—in gas diffusion*, the rate of a substance that passes through a material (diffuser) under given conditions.

3.2 Definitions of Terms Specific to This Standard:

3.2.1 *collapse time, n—in foam testing*, the time in seconds, for zero foam to appear after the air is disconnected at the end of the five minute air blowing time.

3.2.2 *dynamic bubble, n—the first bubble to pass through and escape from the diffuser followed by a continuous succession of bubbles when testing for the pore diameter in Annex A1.*

3.2.2.1 *Discussion*—When a diffuser is immersed in a liquid such as propan-2-ol, air can be trapped in the pores. It can escape eventually or as soon as a pressure is applied to the diffuser. When testing for pore diameter (Annex A1), the escape of such bubbles is to be ignored.

3.2.3 *foam stability, n—in foam testing*, the amount of static foam remaining at specified times following the disconnecting of the air supply.

¹ This test method is under the jurisdiction of ASTM Committee D02 on Petroleum Products and Lubricants and is the direct responsibility of Subcommittee D02.06 on Analysis of Lubricants.

Current edition approved Nov. 10, 2001. Published January 2002. Originally published as D 6082 – 97. Last previous edition D 6082 – 00.

² Annual Book of ASTM Standards, Vol 05.01.

³ Annual Book of ASTM Standards, Vol 14.03.

⁴ Annual Book of ASTM Standards, Vol 14.02.

⁵ Available from Institute of Petroleum, 61 New Cavendish St., London, W1G 7AR, U.K.

3.2.3.1 *five-second foam stability*—the amount of static foam present 5 s after disconnecting the air supply.

3.2.3.2 *fifteen-second foam stability*—the amount of static foam present 15 s after disconnecting the air supply.

3.2.3.3 *one-minute foam stability*—the amount of static foam present 1 min after disconnecting the air supply.

3.2.3.4 *five-minute foam stability*—the amount of static foam present 5 min after disconnecting the air supply.

3.2.3.5 *ten-minute foam stability*—the amount of static foam present 10 min after disconnecting the air supply.

3.2.4 *foaming tendency, n*—in foam testing, the amount of static foam immediately before the cessation of air flow.

3.2.5 *kinetic foam, n*—entrained air that has been created by the passage of air through the diffuser during the test (see Fig. 1).

3.2.5.1 *Discussion*—Because the process of passing air through the diffuser and the oil sample during the test has resulted in an increase in volume and because such entrained air can be considered as foam on its way to being made, the term kinetic foam has been introduced.

3.2.6 *percent volume increase, n*—in foam testing, the increase in total volume expressed as a percentage of the initial total volume with diffuser in place at test temperature.

3.2.7 *static foam, n*—foam that has been created by the passage of air through the diffuser during the test (see Fig. 1).

3.2.8 *total volume, n*—in foam testing, the volume of foam, liquid, diffuser, and submersed portion of delivery tube (see Fig. 1).

3.2.8.1 *initial total volume (V_1), n*—in foam testing, the volume of the foam, liquid, diffuser, and submersed portion of the delivery tube at test temperature prior to connecting the air supply.

3.2.8.2 *final total volume (V_2), n*—in foam testing, the volume of the foam, liquid, diffuser, and submersed portion of the delivery tube just before disconnecting the air supply.

3.2.9 *top volume, n*—the volume of the foam (if any), liquid, diffuser, and the submersed portion of the delivery tube (see Fig. 1).

3.2.10 *zero foam, n*—in foam testing, occurs when any portion of the top surface of the liquid is free of bubbles.

3.2.11 *bottom volume*—the volume of liquid sample, that is, sample substantially free of air, at any given time during the test.

4. Summary of Test Method

4.1 A measured quantity of sample is heated to 49°C for 30 min and allowed to cool to room temperature. The sample is transferred to a 1000 mL graduated cylinder, heated to 150°C, and aerated at 200 mL/min with dry air for 5 min with a metal diffuser. The amount of foam generated before disconnecting the air, the amount of static foam at optional times after disconnecting the air (list of options in Section 10); and the time for the foam to collapse are measured and the percent increase in total volume calculated.

5. Significance and Use

5.1 The tendency of oils to foam at high temperature can be a serious problem in systems such as high-speed gearing, high volume pumping, and splash lubrication. Foaming can cause inadequate lubrication, cavitation, and loss of lubricant due to overflow, and these events can lead to mechanical failure.

5.2 Correlation between the amount of foam created or the time for foam to collapse, or both, and actual lubrication failure has not been established. Such relations should be empirically determined for foam sensitive applications.

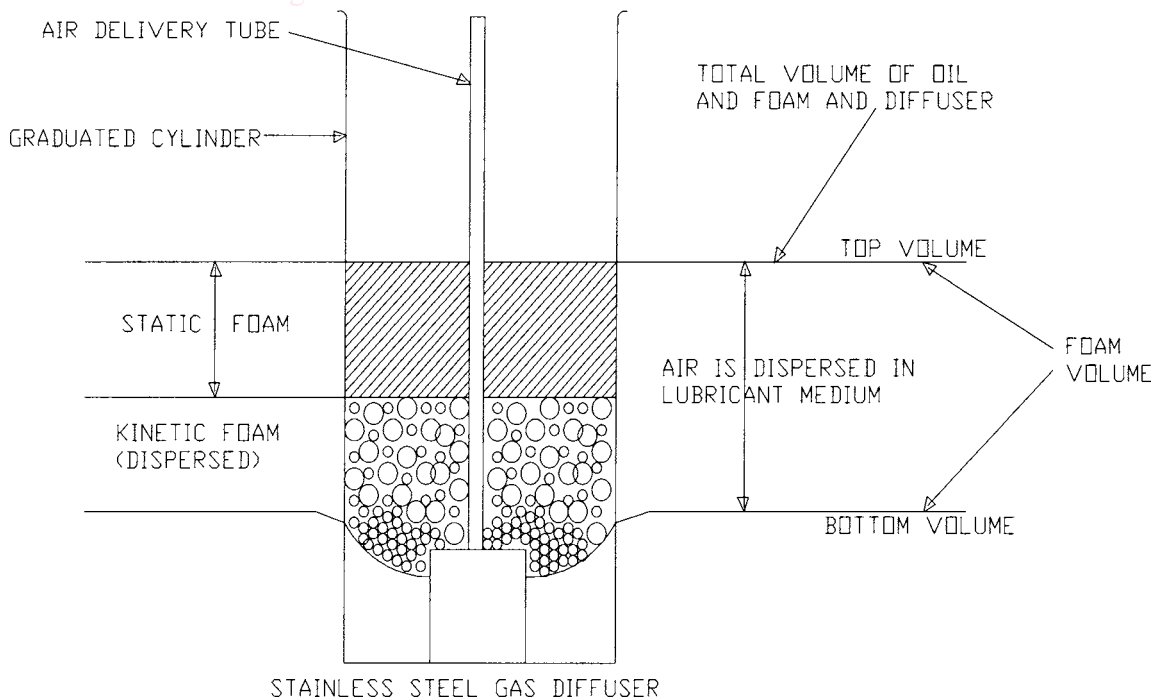

FIG. 1 Terminology Diagram

6. Apparatus

6.1 *Heating Bath*, any heating system capable of maintaining a sample temperature of $150 \pm 1^\circ\text{C}$ (see Fig. 2).

NOTE 1—The precision of this test method was determined using only liquid baths.

6.1.1 *Heating Transfer Fluid*, any liquid with low volatility, at the test temperature, chemical stability and sufficient low viscosity to permit stirring.

NOTE 2—A 4 to 7 mm²/s (cSt) polyalphaolefin has been found to be a suitable fluid. Silicone fluids are foam inhibitors and their use may alter the foam characteristics of the test sample and should be discouraged.

NOTE 3—A slow purge of nitrogen gas through the fluid, or as a blanket over the bath fluid, reduces darkening (oxidation) of the bath fluid.

6.2 *Graduated Cylinder*, 1000 mL, fitted with a device to overcome buoyancy if a liquid bath is used and modified to have a circular top. It shall be capable of withstanding the extreme temperature conditions of this test method.

NOTE 4—A heavy metal ring large enough to fit over the outside and rest on the bottom of the cylinder has been found to be suitable to overcome buoyancy.

NOTE 5—Graduated cylinders having a pouring spout can be prepared for this test method by making a horizontal cut below the spout and removing the part above the cut. The cut edges of the cylinder should be fire-polished or smoothed by grinding.

6.3 *Flow Meter and Regulator*, calibrated and capable of maintaining air flow volume of 200 ± 5 mL/min.

6.3.1 A gas volume meter graduated in hundredths of a litre, or a technically equivalent flow measuring device, with sufficient capacity to measure a flow rate of at least 6000 mL/min, while generating a back pressure of no more than 10 mm of water, is required.

6.4 *Laboratory Oven*, without fan, capable of maintaining $49 \pm 1^\circ\text{C}$.

6.5 *Stirrer*, capable of 500 rpm \pm 100 rpm, fitted with a 1½-in., 3-blade, 1.5-pitch marine propeller.

6.6 *Stainless Steel Diffuser*, 5 µm stainless steel diffuser meeting the specifications of pore size 15 to 60 µm and permeability between 3000 to 6000 mL/min when tested according to the method given in Annex A1 (see Fig. 3).

6.6.1 Calibration verification of new diffusers and calibration after each set (10 samples or less) of evaluations is required.

6.7 *Thermometer*, or other temperature sensing device capable of measuring $150 \pm 0.2^\circ\text{C}$. An ASTM thermometer Specification E 1 No. 41C-86, or equivalent, is suitable.

6.8 *Timing Device*, capable of measuring minutes and seconds (± 1 s).

6.9 *High Speed Blender*, with a container capacity of one litre, capable of maintaining a speed of 22 000 rpm (± 2000).

7. Reagents

7.1 *Purity of Reagents*—Reagent grade chemicals shall be used in all tests. Unless otherwise indicated, it is intended that

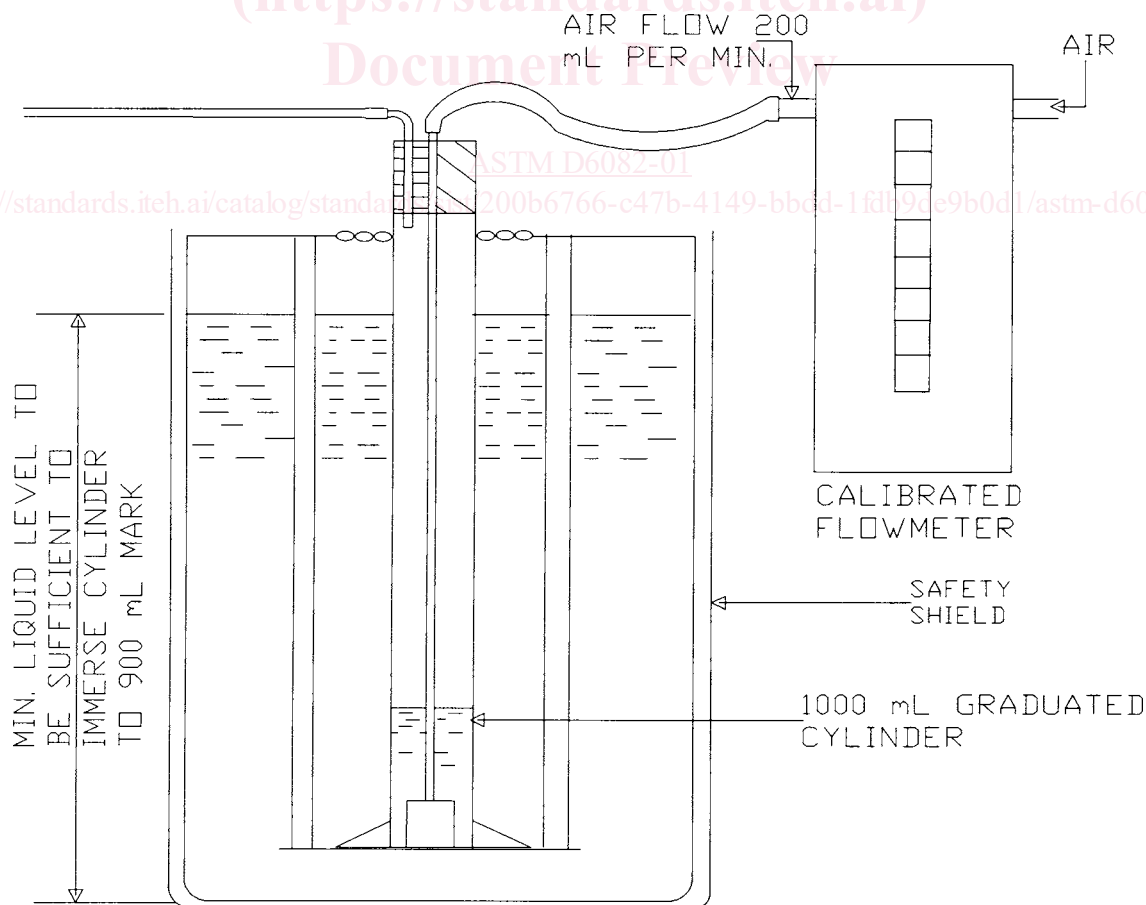
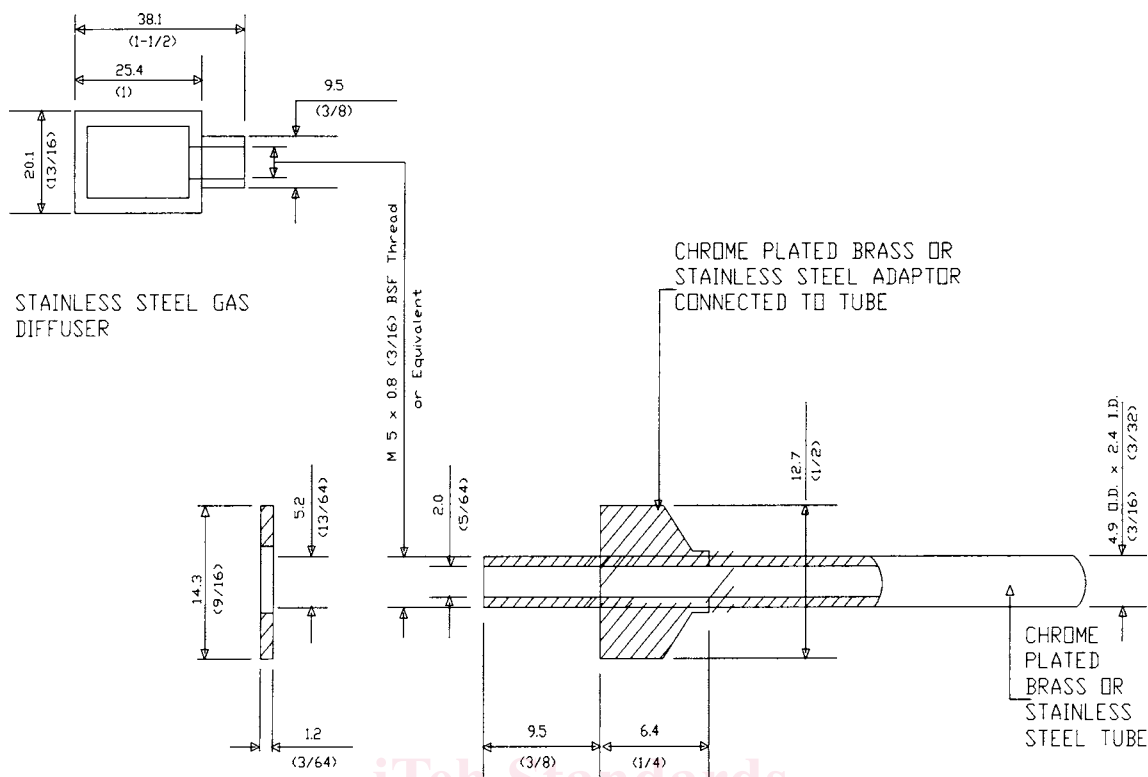

FIG. 2 Typical Liquid Bath



WASHER TYPICAL AIR TUBE ASSEMBLY

Document Preview

Dimensions are Millimeters
(Inches)

FIG. 3 Gas Diffuser and Air Tube Dimensions

all reagents conform to the specifications of the Committee on Analytical Reagents of the American Chemical Society where such specifications are available.⁶ Other grades may be used, provided it is first ascertained that the reagent is of sufficiently high purity to permit its use without lessening the accuracy of the determination.

7.2 **Acetone**, (**Warning**— Extremely flammable. Vapors may cause flash fire.)

7.3 **Compressed Air**, hydrocarbon free and dry to a dew point of -60°C or lower.

7.4 **Heptane**, (**Warning** — Flammable. Vapor harmful.)

7.5 **Propan-2-ol**, (**Warning** — Flammable. Vapor harmful.)

7.6 **Toluene**, (**Warning** — Flammable. Vapor harmful.)

NOTE 6—Solvents with equivalent cleaning characteristics can be substituted for toluene.

⁶ *Reagent Chemicals, American Chemical Society Specifications*, American Chemical Society, Washington, DC. For suggestions on the testing of reagents not listed by the American Chemical Society, see *Analar Standards for Laboratory Chemicals*, BDH Ltd., Poole, Dorset, U.K., and the *United States Pharmacopeia and National Formulary*, U.S. Pharmacopeial Convention, Inc. (USPC), Rockville, MD.

8. Hazards

8.1 **Warning**—Users of this test method shall be fully trained and familiar with all normal laboratory practice, or under the immediate supervision of such a person. It is the responsibility of the operator to ensure that all local legislative and statutory requirements are met.

8.2 **Warning**—Cleaning solvents have flash points lower than usual laboratory ambient temperatures. Avoid the possibility of a fire or explosion.

8.3 **Precaution**—The fumes from the test oil and bath must be vented in a manner compatible with local environmental regulations.

8.4 **Warning**—Some apparatus assemblies can have as much as 20 L of bath oil at 150°C. Therefore, in the event of a breakage of the containing vessel, suitable containment of the spill is advisable.

9. Preparation of Apparatus

9.1 Thorough cleansing of the test cylinder, gas diffuser, and air-inlet tube is essential after each use to remove any additive remaining from previous tests which can seriously interfere with results of subsequent tests.