



Designation: **D5478 – 13 D5478 – 13 (Reapproved 2018)**

Standard Test Methods for Viscosity of Materials by a Falling Needle Viscometer¹

This standard is issued under the fixed designation D5478; the number immediately following the designation indicates the year of original adoption or, in the case of revision, the year of last revision. A number in parentheses indicates the year of last reapproval. A superscript epsilon (ϵ) indicates an editorial change since the last revision or reapproval.

1. Scope*~~Scope~~

1.1 These test methods cover the measurement of the viscosity of Newtonian and non-Newtonian liquids. These test methods are applicable to liquids having viscosities in the range from 5×10^{-4} to 10^3 Pa·s (0.5 to 10^6 cP). The shear rate range is dependent upon the needle used and viscosity of the liquid and may vary from 10^{-4} to 10^3 s⁻¹. With an extension bar and applied weight, a shear rate of 10^4 s⁻¹ may be achieved.

1.2 The yield stress of liquids having this property may also be determined.

1.3 These test methods consist of determining liquid viscosities of Newtonian and non-Newtonian fluids (clear or opaque) by measuring the steady-state (constant) or terminal velocities of cylindrical needles as they fall through the test liquid under the influence of gravity. Yield stresses of non-Newtonian liquids may be measured using the same procedure.

1.4 The values stated in SI units are to be regarded as standard. No other units of measurement are included in this standard.

1.5 *This standard does not purport to address all of the safety concerns, if any, associated with its use. It is the responsibility of the user of this standard to establish appropriate safety, health, and environmental practices and determine the applicability of regulatory limitations prior to use.*

1.6 *This international standard was developed in accordance with internationally recognized principles on standardization established in the Decision on Principles for the Development of International Standards, Guides and Recommendations issued by the World Trade Organization Technical Barriers to Trade (TBT) Committee.*

2. Referenced Documents

2.1 *ASTM Standards:*²

E1 Specification for ASTM Liquid-in-Glass Thermometers

E2251 Specification for Liquid-in-Glass ASTM Thermometers with Low-Hazard Precision Liquids

3. Terminology

3.1 *Definitions:*

3.1.1 *dilatant or shear thickening fluid, n*—fluid in which the apparent viscosity increases with increasing shear rate.

3.1.2 *Newtonian fluid, n*—fluid in which the dynamic viscosity does not vary with shear rate but only with the temperature and pressure.

3.1.3 *Non-Newtonian fluid, n*—fluid in which the dynamic viscosity varies with shear rate over at least some shear rate range.

3.1.3.1 *Discussion—*

This viscosity is sometimes referred to as the “apparent viscosity” since it is not a true property of the fluid but a variable depending on the shear rate. The viscosity of most non-Newtonian fluids fits a power law expression. A power law fluid is defined by the following equation:

$$\eta_a = K(d\gamma/dt)^{n-1} \quad (1)$$

¹ These test methods are under the jurisdiction of ASTM Committee D01 on Paint and Related Coatings, Materials, and Applications and are the direct responsibility of Subcommittee D01.24 on Physical Properties of Liquid Paints and Paint Materials.

Current edition approved Feb. 1, 2013; Sept. 1, 2018. Published February 2013; September 2018. Originally approved in 1993. Last previous edition approved in 2009; 2013 as published as D5478 – 09; D5478 – 13. DOI: 10.1520/D5478-13.10.1520/D5478-13R18.

² For referenced ASTM standards, visit the ASTM website, www.astm.org, or contact ASTM Customer Service at service@astm.org. For *Annual Book of ASTM Standards* volume information, refer to the standard's Document Summary page on the ASTM website.

*A Summary of Changes section appears at the end of this standard

where:

- η_a = apparent viscosity, Pa·s (or dyne·s/cm² = P), mPa·s = cP,
 K = fluid consistency, Pa·sⁿ (or dyne·sⁿ/cm²),
 dy/dt = shear rate or velocity gradient, 1/s, and
 n = flow behavior index, dimensionless.

3.1.4 *pseudoplastic or shear thinning fluid, n*—fluid in which the apparent viscosity decreases with increasing shear rate.

3.1.5 *viscosity, n*—the ratio between an applied shear stress to the resulting shear rate (velocity gradient) is defined as the dynamic viscosity. It is a measure of the resistance to flow of a fluid.

3.1.5.1 *Discussion*—

In the SI unit system, the units of viscosity are Pa·s. One mPa·s is equal to one centipoise (cP).

3.1.6 *yield stress, n*—some fluids when subjected to a shear stress behave as deformable solids until a certain critical shear stress (yield stress or yield value) is reached after which they behave as fluids.

3.1.6.1 *Discussion*—

Examples of such fluids include many paints and pigment pastes and certain food materials such as ketchup.

4. Summary of Test Methods

4.1 Test Method A consists of determining the viscosity of Newtonian liquids.

4.2 Test Method B consists of determining the apparent viscosity and shear rate of pseudoplastic and dilatant fluids in the power law region.

4.3 Test Method C consists of determining the apparent viscosity and shear rate of pseudoplastic and dilatant fluids outside of the power law region.

4.4 Test Method D consists of determining the yield stress of liquids that have such a property.

5. Significance and Use

5.1 These test methods are applicable for measuring the rheological properties of varnishes and paints. In particular, the low to moderate shear rate measurements provide information related to sag resistance, leveling, etc.

<https://standards.iteh.ai/catalog/standards/sist/209b979b-585d-431f-9e93-89bb114a77fa/astm-d5478-132018>

6. Apparatus

6.1 *Viscometer, falling-needle-type* and associated equipment listed as follows:

6.1.1 *Falling Needle Viscometer*^{3,4,5}—A schematic of the falling needle viscometer is shown in Fig. 1. The viscometer consists of a vertical cylindrical test section of diameter D . The liquid specimen is placed in the test section and the specimen's temperature is maintained constant by means of a constant temperature bath that circulates a liquid through another cylindrical container (water jacket) that is coaxial to the test section. A thin hollow cylinder of length L with hemispherical ends and diameter d (the needle) is aligned with the axis of the test section and allowed to fall under the influence of gravity. The needle has a small weight in its forward end that may be varied to change its density. Another type of needle is connected at the top with an extension bar and a weight holder so that external weights may be added to increase the effective density of the needle and the maximum achievable shear rate. With any needle, terminal velocity is measured by determining the needle transit time between two circumferential marks a known distance apart on the test section (for opaque liquids this can be done by an automatic sensing device, such as a magnetic sensor, etc.). With a knowledge of the terminal velocity, the liquid and needle densities, the geometric constants of the system (L , D , d), the viscosity of a Newtonian fluid can be calculated from the instrument theory. For a non-Newtonian fluid whose viscosity depends upon the shear rate, a series of needles are dropped. The falling needle is an absolute method of viscosity measurement that does not need any instrument calibration. However, it may be checked through use of known certified viscous fluids such as standard oils.

³ Park, N. A., and Irvine, T. F., Jr., "Measurements of Rheological Fluid Properties with the Falling Needle Viscometer," *Review of Scientific Instruments*, Vol 59, 1988, pp. 2051–2058.

⁴ Park, N. A., and Irvine, T. F., Jr., "The Falling Needle Viscometer, A New Technique for Viscosity Measurements," *American Laboratory*, Vol 20, November 1988, pp. 57–63.

⁵ The sole source of supply of the falling needle viscometer known to the committee at this time is Stony Brook Scientific, Ltd., 914 Fillmore Rd., Norristown, PA 19403. If you are aware of alternative suppliers, please provide this information to ASTM International Headquarters. Your comments will receive careful consideration at a meeting of the responsible technical committee,¹ which you may attend. This instrument may be interfaced with a computer for data collection and analysis. A computer program is available for data analysis for instruments that are not interfaced.

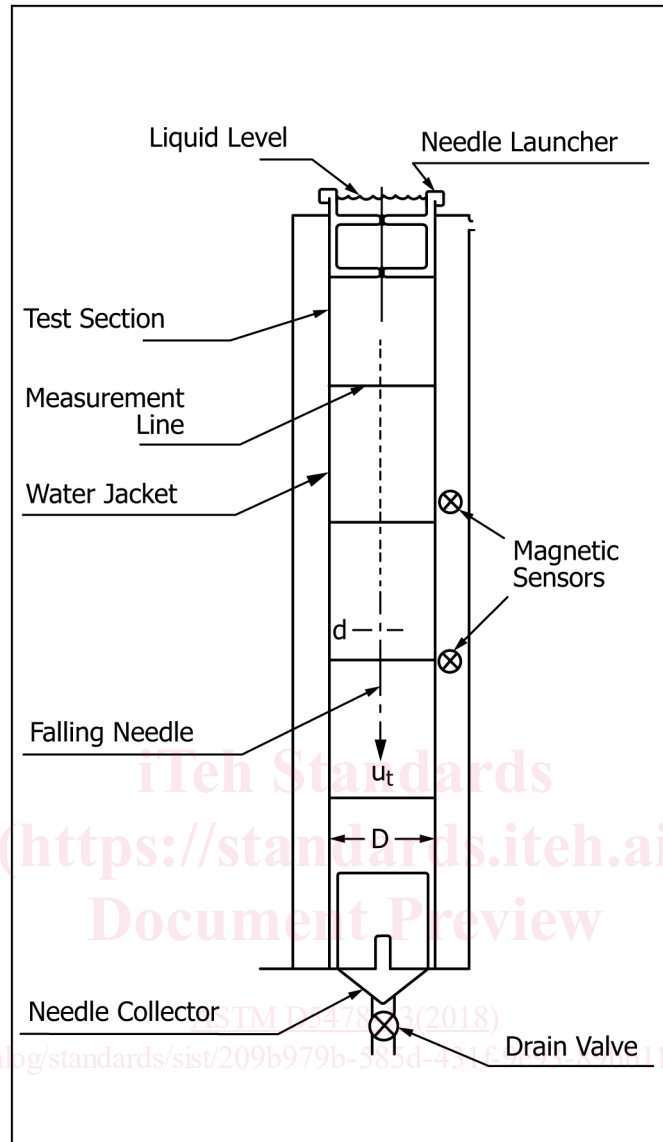

FIG. 1 Schematic of Falling Needle Viscometer

6.1.2 *Thermometer*—A thermometric device calibrated to 0.1°C whose accuracy, precision, and sensitivity are equal to or better than the ASTM thermometers described in Specifications E1 or E2251. The use of non-mercury thermometers or other devices is highly recommended.

6.1.3 *Circulating Liquid Bath*, capable of maintaining the test specimen temperature to $\pm 0.1^\circ\text{C}$.

6.1.4 *Stopwatch or Electronic Device*, capable of measuring to ± 0.01 s or an automatic sensing device with the same accuracy.

7. Preparation of Specimen

7.1 After opening the specimen container, mix the fluid gently with a glass rod for 5 min.

7.2 Pour the specimen carefully into the test section so as to minimize the formation of air bubbles. If available, a syringe is useful for this purpose.

7.3 Remix the specimen in the test container using the needle retriever rod by pushing it up and down four times at a velocity of approximately 4 cm/s.

7.4 Allow the specimen to remain at rest in the test section for a minimum of 5 min or until any air bubbles have risen to the surface. Longer rest times may be used in the case of yield stress measurements.