



Designation: E2359/E2359M – 13 (Reapproved 2018)

Standard Test Method for Field Pull Testing of an In-Place Exterior Insulation and Finish System Clad Wall Assembly¹

This standard is issued under the fixed designation E2359/E2359M; the number immediately following the designation indicates the year of original adoption or, in the case of revision, the year of last revision. A number in parentheses indicates the year of last reapproval. A superscript epsilon (ϵ) indicates an editorial change since the last revision or reapproval.

1. Scope

1.1 This test method covers a procedure to determine the resistance of a section of the exterior insulation and finish system (EIFS) to outward loads imposed on an existing exterior wall assembly that has been in place on the building for an unspecified period of time. It is destructive in nature within the localized areas tested and requires appropriate repair of the EIFS cladding and sheathing once the test procedure has been completed. This test procedure utilizes mechanical methods to obtain information, which may be helpful in evaluating the natural application of negative wind loads on the EIFS assembly. Some variability of results should be anticipated within the wall assembly tested due to differences in installation procedures, exposure, or abuse subsequent to application.

1.2 This test method is suitable for use on cladding assemblies that have been in place a short time (new construction), as well as for longer periods in order to evaluate detrimental effects on the EIFS lamina, insulation attachment, substrate integrity, and attachments after exposure to weather and other environmental conditions. It is not intended to evaluate the performance of structural framing. Test results on any particular building may be highly variable depending on specimen location and condition, and are subject to interpretation by the test specifier.

1.3 The values stated in either SI units or inch-pound units are to be regarded separately as standard. The values stated in each system may not be exact equivalents; therefore, each system shall be used independently of the other. Combining values from the two systems may result in non-conformance with the standard.

1.4 *This standard may involve hazardous materials, operations, or equipment. This standard does not purport to address all of the safety concerns associated with its use. It is the responsibility of the user of this standard to establish*

appropriate safety, health, and environmental practices and to determine the applicability of regulatory limitations prior to use.

NOTE 1—Due to variations in exposure and construction assemblies, field specimens selected for testing utilizing this test method may experience sudden failure and release of the imposed loads. See [Note 7](#) for further information.

1.5 *This international standard was developed in accordance with internationally recognized principles on standardization established in the Decision on Principles for the Development of International Standards, Guides and Recommendations issued by the World Trade Organization Technical Barriers to Trade (TBT) Committee.*

2. Referenced Documents

2.1 *ASTM Standards:*²

[D3665 Practice for Random Sampling of Construction Materials](#)

[E631 Terminology of Building Constructions](#)

[E2110 Terminology for Exterior Insulation and Finish Systems \(EIFS\)](#)

[E2128 Guide for Evaluating Water Leakage of Building Walls](#)

2.2 *American Society of Civil Engineers (ASCE):*³

[SEI/ASCE 7-05, Minimum Design Loads for Buildings and Other Structures](#)

3. Terminology

3.1 For general terminology regarding EIFS and building in general, see Terminology [E2110](#) (for EIFS terms) and Terminology [E631](#) (for buildings in general).

3.2 *Definitions of Terms Specific to This Standard:*

3.2.1 *face delamination, n*—failure mode by which the face of the sheathing loses bond or delaminates from the sheathing core, either partially or fully.

¹ This test method is under the jurisdiction of ASTM Committee E06 on Performance of Buildings and is the direct responsibility of Subcommittee E06.58 on Exterior Insulation and Finish Systems (EIFS).

Current edition approved Sept. 1, 2018. Published September 2018. Originally approved in 2006. Last previous edition approved in 2013 as E2359/E2359M–13. DOI: 10.1520/E2359_E2359M–13R18.

² For referenced ASTM standards, visit the ASTM website, www.astm.org, or contact ASTM Customer Service at service@astm.org. For *Annual Book of ASTM Standards* volume information, refer to the standard's Document Summary page on the ASTM website.

³ Available from American Society of Civil Engineers (ASCE), 1801 Alexander Bell Dr., Reston, VA 20191, <http://www.asce.org>.

3.2.2 *fastener pull-out from stud, n*—failure mode by which fastener releases from the substrate.

3.2.3 *fastener pull-through, n*—failure mode by which the head of the fastener pulls through the sheathing, insulation, or substrate.

3.2.4 *lamina release, n*—failure mode by which the EIFS base coat and finish coat release their bond to the underlying thermal insulation board layer.

3.2.5 *thermal insulation board failure, n*—cohesive failure within the thermal insulation board.

4. Significance and Use

4.1 The purpose of this test method is to assess the installation adequacy and the overall effects of service-related deterioration (moisture, etc.) on the EIFS wall assembly as opposed to small localized areas of degradation. Resistance to pull testing as determined by this test is used as one of the factors in evaluating the EIFS assembly on a specific project. The values obtained by this test method are not purported to be representative of the actual wind load capacity or other structural properties of a specific EIFS clad wall installation, but may be helpful in assessing such load capacities.

4.2 Since this test is used for field evaluation of existing facilities, load results obtained from this test must be interpreted based on sound engineering practice, applicable building regulations, and codes having jurisdiction. It is the discretion of the test specifier to directly utilize the results derived by this test method, or else to utilize the test results with an appropriate factor of safety to obtain acceptable working loads for each project.

4.3 This method is intended for use on test specimens occurring or installed on existing buildings. The loss of outward wind load resistance of an EIFS wall assembly after exposure to moisture and other weather conditions may compromise the ability of the cladding or other wall components to perform adequately in place. This test method does not provide any means by which the test results may be generalized to the larger wall area. Such efforts should be based on experience and engineering judgement.

4.4 The manner in which the test load is applied may affect the load capacity obtained from using this test method. A discussion of various load application techniques and their effects is given in [Appendix X1](#).

5. Apparatus

5.1 Electronic rebar locator or metal detector sensitive enough to locate metal studs or fasteners of the underlying structural framing through the EIFS assembly.

5.2 Pull test frame fabricated from metal or wood, as required, with capability of applying a concentric pull force to the test module and distributing reaction force on adjacent wall components. Pull test frame shall be provided, as a minimum, with a worm-gear winch and a nylon strap or wire rope capable of applying load to test module in controlled manner with incrementally increasing load intensities. Alternative means of applying a consistent load using electro-servo motors or

hydraulic units are also acceptable, provided they are capable of applying consistent, uniform load. It is intended that the pull test frame be easily transportable and relocated so that it can be readily used on saw-horses, scaffolding, or a swing-stage. An example of an acceptable test frame is shown in [Fig. 1](#).

5.3 Electronic load cell with digital force gage having a capacity of at least 4450 N [1000 lbf.], and an accuracy of $\pm 2\%$.

5.4 610 mm by 610 mm [24 in. by 24 in.] wooden pull test modules comprised of 19 mm [$\frac{3}{4}$ in.] thick plywood bonding panels (one for each specimen intended for testing), and one 19 mm [$\frac{3}{4}$ in.] thick plywood bolting panel, which is moved from specimen-to-specimen. As each specimen is prepared for testing the bonding panels and bolting panels shall be fastened together using twelve (12) 5.5 mm (#12) or [0.215 in.] diameter by 38 mm [$1\frac{1}{2}$ in.] long wood screws or lag bolts installed in a prescribed pattern. See [Figs. 2-5](#). Adhere one 19 mm [$\frac{3}{4}$ in.] thick bonding panel to the surface of the EIFS in place at each specimen location. For testing purposes, temporarily fasten the bolting panel at each adhered bonding plate in succession with appropriate hardware, immediately prior to testing.

NOTE 2—Screw hole locations for both the bonding panels and the bolting panel must align for proper attachment; use bolting panel as a drilling template to achieve consistent screw locations and alignment on all bonding panels.

5.5 Miscellaneous bolts and connection hardware.

6. Test Specimen

6.1 Sampling locations and number of specimens shall be specified by the user. Primarily, this test method is intended to implement qualitative evaluation techniques that lead to an accumulation of information in an orderly and efficient manner in accordance with procedures prescribed within [Guide E2128](#). If a hybrid method using a combination of qualitative and quantitative evaluation techniques is desired by the test specifier, then a random number generator method may be utilized to establish locations of test specimens required to represent the entire building population. Include additional test specimens at locations of suspected or potential problems, such as below window corners, at wall base, and so forth.

NOTE 3—For the hybrid method using a combination of qualitative and quantitative evaluation techniques, a selection method based on [Practice D3665](#) may be utilized for this purpose.

6.2 Locate metal studs within wall system (or else fastener heads at wood-framed system) using rebar locator or metal detector, and determine elevation or height of the specimen.

6.3 For stud spacing less than 610 mm [24 in.] (on center), mark 610 mm by 610 mm [24 in. by 24 in.] outline on the surface of EIFS that is centered over two adjacent studs. For stud spacing 610 mm [24 in.] and greater, mark an outline on the EIFS surface that is 610 mm [24 in.] high and with a width equal to the stud spacing plus 75 mm [3 in.], which is centered over two adjacent studs. If foam fasteners are present or suspected within the EIFS clad wall assembly, locate the heads of foam fasteners using a rebar locator, then arrange bonding panel in manner that evenly distributes the load across the test

NOTE: METRIC DIMENSIONS GIVEN IN S.I. UNITS; U.S. EQUIVALENT IN BRACKETS

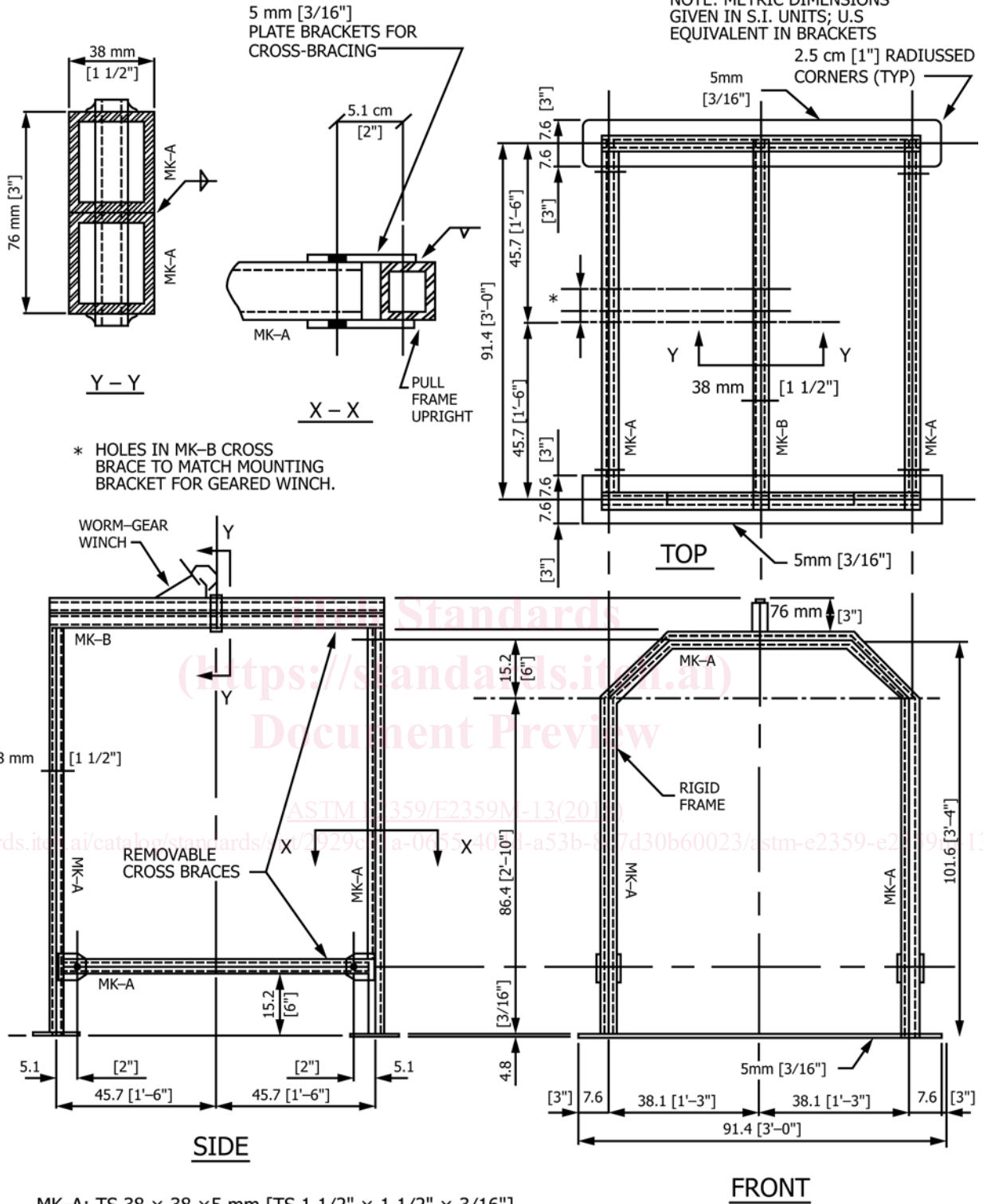

FIG. 1 Pull Test Frame

NOTE: METRIC DIMENSIONS
GIVEN IN S.I. UNITS, U.S.
EQUIVALENT IN BRACKETS

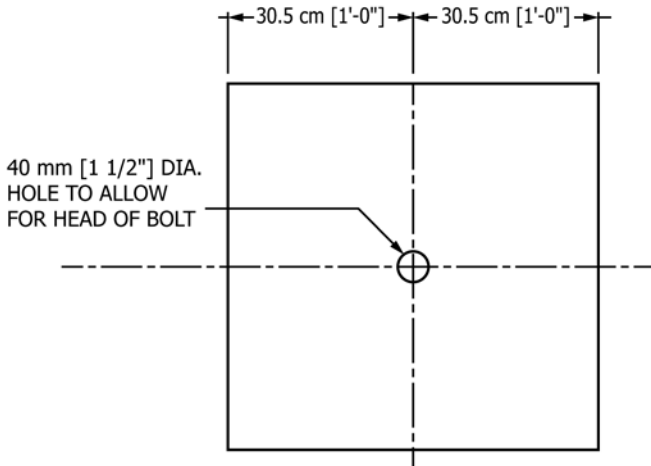

FIG. 2 Bonding panel

NOTE: METRIC DIMENSIONS
GIVEN IN S.I. UNITS, U.S.
EQUIVALENT IN BRACKETS]

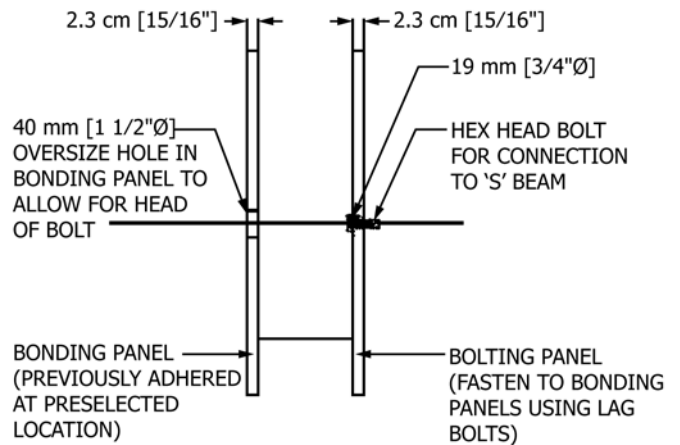

FIG. 4 Plywood Assembly

NOTE: METRIC DIMENSIONS
GIVEN IN S.I. UNITS, U.S.
EQUIVALENT IN BRACKETS

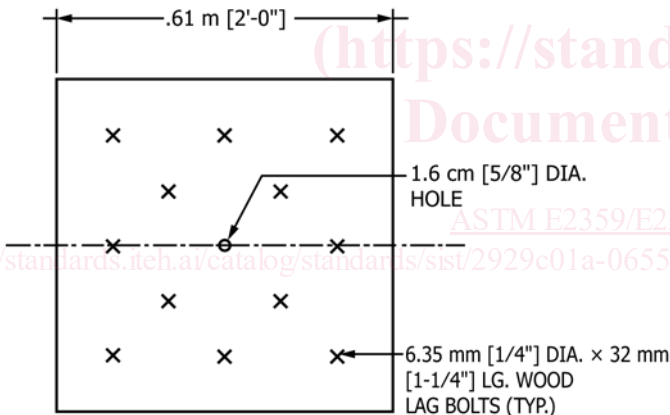

FIG. 3 Bolting Panel

NOTE: METRIC DIMENSIONS
GIVEN IN S.I. UNITS, U.S.
EQUIVALENT IN BRACKETS

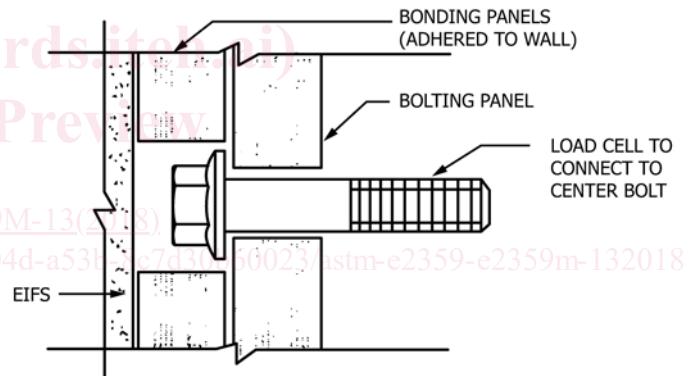

FIG. 5 Detail of Bonding and Bolting Panel with Bolt in Center Hole

specimen and mark the outline on the EIFS surface. At each outline marked on the wall, carefully cut through the EIFS lamina, thermal insulation board, and sheathing substrate, being careful to avoid excessive vibration during specimen preparation that may adversely affect test results. Efforts should also be made to avoid cutting or damaging the wall studs.

NOTE 4—For EIFS cladding applied directly to a masonry substrate, saw blade depth should be set to extend 3 mm [$\frac{1}{8}$ in.] to 6 mm [$\frac{1}{4}$ in.] into the masonry.

6.4 Adhere one 19-mm [$\frac{3}{4}$ -in.] thick, 610 mm [24 in.] square plywood bonding panel to the previously cut EIFS surface (centered) at designated test location using polyester adhesive, adhesive expanding foam, or quick-reaction epoxy

cement; temporarily support test module in place on the wall as required. Allow an adequate time for curing of the adhesive considering effect of temperature on cure time of adhesive.

NOTE 5—Alternative adhesives may be used that are not detrimental to the lamina or underlying foam insulation system.

7. Procedure

7.1 Obtain information regarding the cladding assembly design wind pressure (DWP) utilized during original construction of the building, or else otherwise determine an appropriate cladding DWP for comparative purposes using local building codes or SEI/ASCE 7-05 analytical procedures. Establish initial load at approximately ten percent (10 %) of cladding design wind pressure.