International Standard



4263

INTERNATIONAL ORGANIZATION FOR STANDARDIZATION • МЕЖДУНАРОДНАЯ ОРГАНИЗАЦИЯ ПО СТАНДАРТИЗАЦИИ • ORGANISATION INTERNATIONALE DE NORMALISATION

Petroleum products — Inhibited mineral oils — Determination of oxidation characteristics

Produits pétroliers — Huiles minérales inhibées — Détermination des caractéristiques d'oxydation

First edition — 1986-11-01

ITeH STANDARD PREVIEW
(standards.iteh.ai)

[ISO 4263:1986](https://standards.iteh.ai/catalog/standards/sist/9a3e57a1-deb6-4706-bdb3-9163a2ce219e/iso-4263-1986)

<https://standards.iteh.ai/catalog/standards/sist/9a3e57a1-deb6-4706-bdb3-9163a2ce219e/iso-4263-1986>

UDC 665.765 : 621.165 : 543.872

Ref. No. ISO 4263-1986 (E)

Descriptors: petroleum products, oils, mineral oils, tests, oxidation tests, determination, oxidation resistance, test equipment.

Foreword

ISO (the International Organization for Standardization) is a worldwide federation of national standards bodies (ISO member bodies). The work of preparing International Standards is normally carried out through ISO technical committees. Each member body interested in a subject for which a technical committee has been established has the right to be represented on that committee. International organizations, governmental and non-governmental, in liaison with ISO, also take part in the work.

Draft International Standards adopted by the technical committees are circulated to the member bodies for approval before their acceptance as International Standards by the ISO Council. They are approved in accordance with ISO procedures requiring at least 75 % approval by the member bodies voting.

International Standard ISO 4263 was prepared by Technical Committee ISO/TC 28, *Petroleum products and lubricants*.

Users should note that all International Standards undergo revision from time to time and that any reference made herein to any other International Standard implies its latest edition, unless otherwise stated.

Petroleum products — Inhibited mineral oils — Determination of oxidation characteristics

1 Scope and field of application

1.1 This International Standard specifies a method for evaluating the oxidation stability of inhibited steam-turbine oils in the presence of oxygen, water, and metallic copper and iron at an elevated temperature. The method is also used for testing other oils such as hydraulic oils and circulating oils having a relative density less than that of water and containing rust and oxidation inhibitors.

1.2 This method is widely used for specification purposes and is considered of value in evaluating the oxidation stability of lubricants, especially those that are prone to water contamination. It should be recognized, however, that correlation between results of this method and the oxidation stability of a lubricant in field service may vary markedly with field service conditions and with various lubricants.

1.3 In the course of testing a lubricant by this method, other signs of deterioration, such as sludge formation or catalyst coil corrosion, may appear which are not reflected in the calculated oxidation lifetime. The application of alternative criteria for evaluation of lubricants using this test method is under investigation.

2 References

ISO 1553, *Unalloyed copper containing not less than 99,90 % of copper — Determination of copper content — Electrolytic method.*

ISO 3170, *Petroleum products — Liquid hydrocarbons — Manual sampling.*

ISO 3405, *Petroleum products — Determination of distillation characteristics.*

3 Principle

A test portion is reacted with oxygen in the presence of water and iron—copper catalyst at 95 °C. The test continues until the measured total acid number of the oil is 2,0 mgKOH/g or above. The number of test hours required for the oil to reach 2,0 mgKOH/g is the "oxidation lifetime."

4 Reagents and materials

During the analysis, unless otherwise stated, use only reagents of recognized analytical grade, and only distilled water or water of equivalent purity.

4.1 Acetone, 99,5 % grade and conforming to the essential requirements given in annex A.

4.2 Catalyst wires.

4.2.1 Low-metalloid iron wire, 1,59 mm in diameter, soft bright annealed and free from rust, of the composition given in annex B. Other equivalent wire may be used, provided that it is found satisfactory in comparative tests using this method.

4.2.2 Electrolytic copper wire, 1,63 mm in diameter, 99,90 % purity (when tested in accordance with ISO 1553). Soft copper wire of an equivalent grade may also be used.

4.3 Detergent, water soluble.

4.4 n-Heptane, knock test grade, conforming to the essential requirements given in annex C.

4.5 Hydrochloric acid, diluted 1 + 3.

Carefully add 1 volume of concentrated hydrochloric acid ($\rho_{20} = 1,19$ g/ml) to 3 volumes of water.

4.6 2-Propanol (Isopropyl alcohol), conforming to the essential requirements given in annex D.

4.7 Oxygen, 99,5 % minimum purity, with pressure regulation adequate to maintain a constant flow of gas through the apparatus. The use of a two-stage pressure regulator on tank oxygen is recommended.

4.8 1,1,1-Trichloroethane.

4.9 Chromic acid, or other suitable cleaning solution.

5 Apparatus

5.1 Oxidation cell, consisting of a test tube, condenser, and oxygen delivery tube, all of borosilicate glass, as shown in figure 1. The test tube shall be marked, without the oxygen delivery tube in position, with a line to indicate a volume of 300 ± 1 ml at 20°C .

5.2 Heating bath, thermostatically controlled, capable of maintaining the test portion in the oxidation cell at a temperature of $95 \pm 0,2^\circ\text{C}$, fitted with a suitable stirring device to provide a uniform temperature throughout the bath, and large enough to hold the desired number of oxidation cells immersed in the heating bath to a depth of 390 ± 10 mm and in the heating liquid itself to a depth of 355 ± 10 mm.

5.3 Flowmeter, with a capacity of at least 3 l/h, and an accuracy of $\pm 0,1$ l/h.

5.4 Heating bath thermometer, conforming to the essential requirements given in annex E.

5.5 Oxidation cell thermometer, having a range from 80 to 100°C , graduated in $0,1^\circ\text{C}$, total length of 250 mm, stem diameter from 6,0 to 7,0 mm, calibrated for 76 mm immersion.

NOTE — A thermometer STL/0,1/80/105 ISO 653 is suitable.

5.6 Thermometer bracket, for holding the oxidation cell thermometer, of stainless steel, having the dimensions shown in figure 2. The thermometer is held in the bracket by two fluoro-elastomer O-rings of approximately 5 mm inside diameter. Alternatively, thin stainless steel wire may be used.

5.7 Wire coiling mandrel, as shown in figure 3.

NOTE — Any arrangement that leads to the coil configuration described in 6.2 is satisfactory.

5.8 Abrasive cloth, silicon carbide, 100-grit with cloth backing. 100-grit corresponds to grains retrieved from sieving between sieves having openings of 180 and 150 μm .

5.9 Syringes, glass, with optional Luer-Lok locking connectors, 10 and 50 ml capacities for sampling, and water additions, respectively.

5.10 Syringe sampling tube, stainless steel tubing, 2,11 mm in outside diameter, 1,60 mm in inside diameter, 610 ± 2 mm long, with one end finished at 90° and the other end fitted with optional Luer-Lok female connector. The optional connector is preferably of elastomeric material such as poly(fluorovinyl chloride) to provide a good seal with the syringe.

5.11 Stopper¹⁾, for optional Luer fitting of syringe sampling tube, made of polytetrafluoroethylene or poly(fluorovinyl chloride).

5.12 Sampling tube holder, for supporting the syringe sampling tube, made of methyl methacrylate resin, having the dimensions shown in figure 4.

5.13 Sampling tube spacer, for positioning the end of the sampling tube above the sampling tube holder, made of a length of plastic tubing poly(vinyl chloride), polyethylene, polypropylene, or polytetrafluoroethylene, having an inside diameter of approximately 3 mm and 51 ± 1 mm length.

5.14 Flexible tubing, poly(vinyl chloride) approximately 6,4 mm inside diameter with a 2,4 mm wall for delivery of oxygen to the oxidation cell.

6 Preparation of apparatus

6.1 Cleaning the catalyst

Immediately prior to winding a catalyst coil, clean a $3,00 \pm 0,01$ m length of the iron wire (4.2.1) and an equal length of the copper wire (4.2.2) with wads of absorbent cotton wet with the *n*-heptane (4.4) and follow by abrasion with the abrasive cloth (5.8) until a fresh metal surface is exposed. Then wipe with dry absorbent cotton until all loose particles of metal and abrasive have been removed. In subsequent operations, handle the catalyst wires with clean cotton, rubber, or plastic gloves to prevent contact with the skin.

6.2 Preparation of the catalyst coil

Twist the cleaned iron and copper wires together at one end for three turns and wind them simultaneously alongside each other on the threaded mandrel (5.7) or equivalent. Using the mandrel described, wind the iron wire (4.2.1) on the deeper thread, 15 mm in diameter, and the copper wire on the 16 mm thread. The smaller diameter allows for the "springback" of the steel wire after winding so as to produce a coil of a uniform inside diameter of 16 mm. Use of a very soft annealed iron wire may allow both wires to be wound on threads of the same diameter. After removing the coil from the mandrel, twist the free ends of the iron and copper wires together for three turns and bend the twisted ends to conform to the shape of the spiral.

The finished dimensions of the coil shall be:

— overall length, mm	225 ± 5
— inside diameter, mm	$16,2 \pm 0,3$
— interturn spacing, mm	$4,1 \pm 0,1$

The turns shall be evenly spaced. If necessary, the coil may be stretched to give the required length.

Prior to storage, rinse coil with a volatile solvent (*n*-heptane) and air dry.

1) Suitable stoppers are available from suppliers of infrared spectrometer sample cells.

6.3 Catalyst storage

The catalyst coil may be stored in a dry, inert atmosphere prior to use. A suitable procedure for catalyst storage is given in annex F. Before use, it should be inspected to ensure that no corrosion products or contaminating materials are present. For overnight storage (less than 24 h), the coil may be stored in *n*-heptane.

NOTE — *n*-Heptane used for catalyst storage should be free of traces of water and corrosive materials. Redistilled *n*-heptane conforming to 5.4 and stored in a tightly sealed bottle is suitable.

6.4 Cleaning the new glassware

Wash new oxygen delivery tubes, condensers, and test tubes with a hot detergent solution and rinse thoroughly with tap water. Clean the interior of the test tubes, exterior of the condensers, and both interior and exterior of the oxygen delivery tubes with the cleaning solution (4.9). Rinse thoroughly with tap water until all cleaning solution is removed. Rinse all parts with water and allow to dry at room temperature or in an oven. The final water rinse may be followed by an isopropyl alcohol (4.6) rinse or acetone (4.1) rinse, to hasten drying at room temperature.

6.5 Cleaning the used glassware

Immediately following termination of a test, drain the oil completely from the test tube. Rinse all the glassware with a hydrocarbon solvent to remove traces of oil, wash with a hot detergent solution using a long-handled brush, and rinse thoroughly with tap water. If deposits still adhere to the glassware, a cleaning method that has been found useful is to fill the test tubes with detergent solution, insert the oxygen delivery tubes and condensers, and place the tubes in the bath (5.2) at test temperature. Several hours soaking in this manner often serves to loosen all adhering deposits except iron oxide. Subsequent rinsing with the hot hydrochloric acid solution (4.5) will serve to remove iron oxide. After all deposits are removed, rinse all glassware with the cleaning solution (4.9). Rinse thoroughly with tap water until all cleaning solution is removed. Rinse all parts with water and allow to dry at room temperature or in an oven. The final water rinse may be followed by an isopropyl alcohol (4.6) rinse or acetone (4.1) rinse, to hasten drying at room temperature. Store glassware in a dry dust-free atmosphere until ready to use.

6.6 Cleaning the used sampling tube

Immediately following termination of a test, drain the oil completely from the sampling tube. Rinse the tube with a hydrocarbon solvent to remove traces of oil. Follow this with a thorough rinse using the 1,1,1-trichloroethane (4.8) to remove any tenacious organic residues. Rinse with hydrocarbon solvent, e.g. *n*-heptane, and blow dry with air or nitrogen.

7 Sampling

Samples for this test may have to be taken from large storage tanks, drums, small containers or even operating equipment. Use the appropriate apparatus and techniques described in ISO 3170.

8 Procedure

8.1 Adjust the heating bath (5.2) to a temperature high enough to maintain the oil in the oxidation test cell (5.1) at the required temperature of $95 \pm 0,2$ °C.

8.2 Pour a sufficient amount of the laboratory sample (clause 7) into the empty oxidation test tube to fill it to the mark. Slide the catalyst coil (4.2) over the inlet of the oxygen delivery tube. If the wires are uneven at one end of the coil, position the coil so that this end is down. Place the oxygen delivery tube with the coil into the test tube. Place the condenser over the oxygen delivery tube and test tube. Place the syringe sampling tube holder (5.12) over the oxygen delivery tube. Insert the syringe sampling tube (5.10) through the syringe sampling tube spacer (5.13), and into the syringe sampling tube holder, as shown in figure 5. Position the bottom end of the syringe sampling tube inside the catalyst coil. Insert a stopper (5.11) in the fitting end of the syringe sampling tube. Immerse the test tube in the heating bath. Adjust the heating bath liquid level so that the tube is immersed in the liquid to a depth of 355 ± 10 mm. Connect the condenser to the cooling water. The temperature of the outlet water shall not exceed 32 °C at any time during the test.

NOTE — As an alternative to using the syringe sampling tube holder and sampling tube spacer, the sampling tube may be secured in position by taping to the oxygen delivery tube using a suitable adhesive tape. The syringe sampling tube is taped to the oxygen delivery tube at a distance of approximately 25 mm above the top of the condenser. The bottom of the syringe sampling tube is positioned at 150 ± 5 mm from the bottom curved end of the oxygen delivery tube.

8.3 Connect the oxygen delivery tube to the oxygen supply (4.7) (see WARNING) through the flowmeter using new poly(vinyl chloride) flexible tubing (5.14) no more than 600 mm in length. Before using, rinse the interior of the new tubing with a volatile solvent (*n*-heptane) and blow dry with air. Adjust the rate of flow to $3 \pm 0,1$ l/h and continue flow for 30 min; then add 60 ml of water to the oxidation cell. Add the water by raising the condenser.

Maintain the oxygen flow rate at $3 \pm 0,1$ l/h by periodic monitoring.

WARNING — Since oxygen vigorously accelerates combustion, it is essential to use safe handling procedures.

8.4 In order to maintain the temperature of the oil/water mixture (test portion temperature) at $95 \pm 0,2$ °C during the time the oxygen is flowing it will be necessary to maintain the temperature of the heating bath at some higher value in order to offset the cooling effect of the gas flow. The temperature required will depend on the heating bath medium, the bath capacity, the rate of circulation of the bath medium and the number of cells in the bath.

To determine the required temperature, set up the bath with the number of cells it is intended to use and, if desired, a dummy cell reserved for the measurement of the test portion temperature. Measure the test portion temperature with the oxygen flowing using only new undepleted test portion or, preferably, the dummy cell. Measure the test portion

temperature using the thermometer (5.5), supported in the oxidation cell by the thermometer bracket (5.6). If the temperature of a test portion and not a dummy has been measured, remove the thermometer immediately after the test portion temperature has become stable in the range $95 \pm 0,2$ °C. Check the temperature as described in various places in a multi-cell bath. Maintain the bath temperature so as to ensure that the temperature is maintained at $95 \pm 0,2$ °C throughout the duration of the test.

NOTE — With the arrangement shown in figure 6, the 76 mm immersion point of the thermometer is positioned at the oil surface. To allow for heating of the stem portion of the thermometer above the immersion point in the upper portion of the test cell, subtract 0,10 °C from the thermometer reading to obtain the true test temperature.

8.5 Add additional distilled water to the oxidation cell as required at least every 2 weeks during the test to restore the water level to the shoulder of the oxygen delivery tube. Add the water using the syringe sampling tube and the 50 ml capacity syringe.

NOTE — In some circumstances, the level of water cannot be observed because of deposits or emulsion formation. Mark the upper oil level of the filled oxidation tube by some suitable means and maintain this level by periodic water additions in order to keep the proper amount of water in the cell. The correct level for water additions may, if desired, be indicated by a movable metal strip (figure 7), which is clamped to the outside of the oxidation test tube by, for example, an adjustable ring-type hose clamp. To use this indicator, set the lower end of the strip at the upper oil level when the test is started. As the test proceeds and water evaporates causing the oil level to fall, add sufficient make-up water, particularly just before test portions are taken, to return the oil level to the level marked by the indicator strip. After each test portion is taken, move the indicator to the new oil level before continuing the test.

8.6 After 500 h of test time, and every 168 h (every week) thereafter, withdraw 3 ml of test oil from the oxidation test cell. This can be accomplished as follows: Without interrupting the oxygen flow, and without changing the position of the syringe sampling tube, remove the sampling tube stopper. Attach a 10 ml syringe to the syringe sampling tube and withdraw and displace approximately 3 ml of test oil twice to displace fluid in the syringe sampling tubing. Then withdraw 6 ml of test oil into the syringe, hold the syringe tube vertically for 15 to 20 s to allow water to settle to the bottom of the syringe tube, and adjust the sample size to 3 ml while holding the syringe vertically. This method allows most of the water withdrawn with the test oil to be returned to the test cell. Replace the syringe sampling tube stopper. Transfer the 3 ml sample into a sample vial for acid number analysis. Shake the test oil sample thoroughly before taking a test portion from the vial for titration.¹⁾

NOTE — Test results by this method are greatly affected by differences in sampling procedure. It is important to adhere strictly to the procedure and schedule for sampling for total acid number. An exception is when the oil is known to have a life shorter than 500 h, then the sampling shall be at the discretion of the operator.

8.7 Discontinue the test when the measured total acid number is 2,0 mgKOH/g or above.

NOTE — The value 2,0 mgKOH/g is taken as the limiting value when testing steam-turbine oils by this method. When oxidation is proceeding rapidly in such oils, values much higher than 2,0 are frequently encountered. At that time, the state of severe oxidation of the oil, as indicated by the high total acid number, is generally confirmed by other signs of degradation such as disagreeable odour formation of deposits, corrosion of the catalyst coil, severe darkening of the oil, and emulsification of the oil water mixture. If such signs of oxidation are noted before the scheduled time for sampling for total acid number, a test portion may be taken and the test discontinued if the measured total acid number is 2,0 mgKOH/g or above.

9 Expression of results

9.1 Method of calculation

Calculate the time t , in hours, required to attain a total acid number (oxidation lifetime) of 2,0 mgKOH/g, using the equation

$$t = t_1 + \left[\frac{2,0 - AV_1}{AV_2 - AV_1} \times (t_2 - t_1) \right]$$

where

t_1 is the number of test hours when the last measured total acid number was less than 2,0;

t_2 is the number of test hours when the last measured total acid number was greater than 2,0;

AV_1 is the total acid number at t_1 h;

AV_2 is the total acid number at t_2 h.

9.2 Precision

The precision of the method, as obtained by statistical examination of inter-laboratory test results in the data range from 700 to 3900 h, is as follows:

9.2.1 Repeatability

The difference between successive test results, obtained by the same operator with the same apparatus under constant operating conditions on identical test material, would in the long run, in the normal and correct operation of the test method, exceed the following values only in 1 case in 20:

$$0,192 \bar{x},$$

where \bar{x} is the mean value.

9.2.2 Reproducibility

The difference between two single and independent results, obtained by different operators working in different laboratories

1) The precision data of this International Standard were determined using the ANSI/ASTM D 3339 method, *Total Acid Number of Petroleum Products by Semi-Micro Color Titration*, and this is the preferred method. Other methods, e.g. ANSI/ASTM D 974-IP 139, ANSI/ASTM D 664-IP 177 or other similar national standards may be used, but the precision of this International Standard using the latter acidity methods is not known.

on identical test material, would in the long run, in the normal and correct operation of the test method, exceed the following values only in 1 case in 20:

$$0,332 \bar{x},$$

where \bar{x} is the mean value.

NOTE — Reproducibility with duplicate tests. If two successive tests are performed by each operator in 9.2.2, the difference between the averages of the two sets of results from the tests would exceed the following values only in 1 case in 20:

$$0,302 \bar{\bar{x}},$$

where $\bar{\bar{x}}$ is the mean value of the two laboratories.

10 Test report

The test report shall contain at least the following information:

- a) the type and identification of the product tested;
- b) a reference to this International Standard or to a national standard;
- c) the result of the test (see 9.1);
- d) any deviation, by agreement or otherwise, from the procedure specified;
- e) the date of the test.

iTeh STANDARD PREVIEW (standards.iteh.ai)

ISO 4263:1986

<https://standards.iteh.ai/catalog/standards/sist/9a3e57a1-deb6-4706-bdb3-9163a2ce219e/iso-4263-1986>

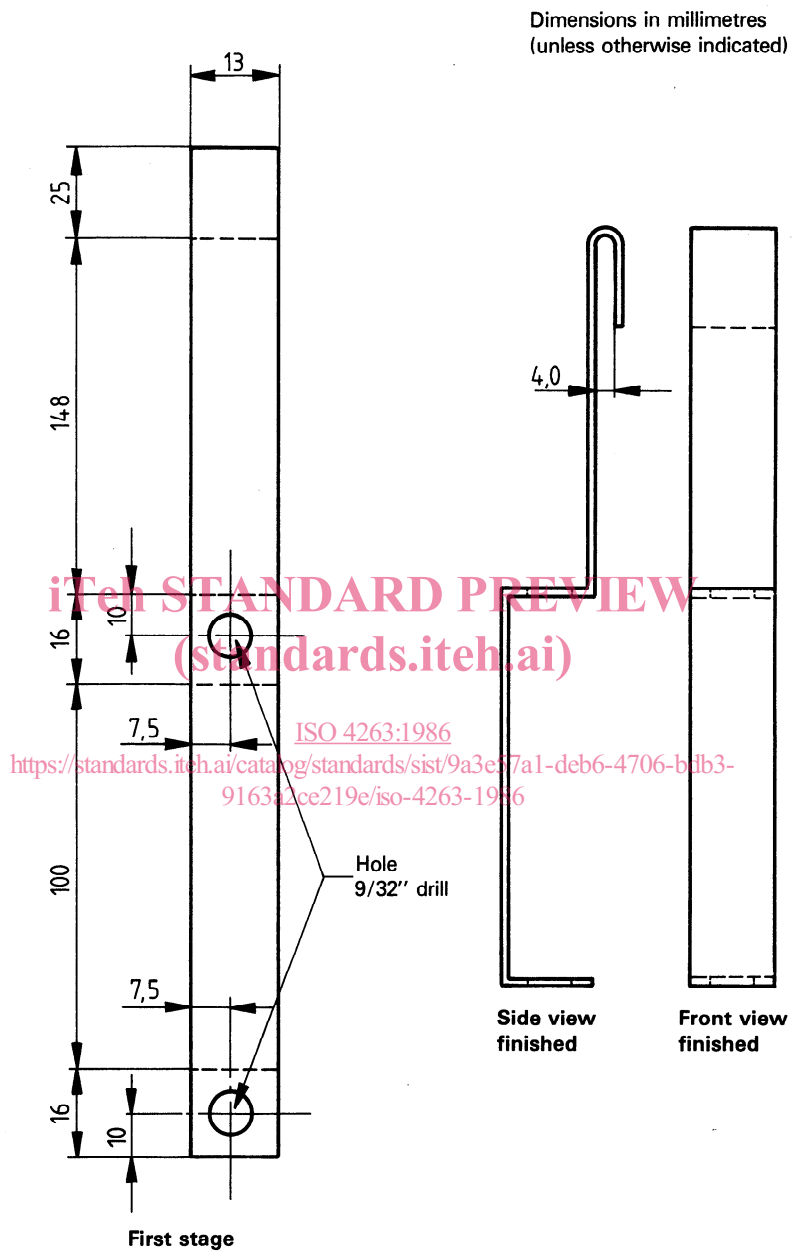

Figure 2 – Thermometer bracket

Dimensions in millimetres
(unless otherwise indicated)

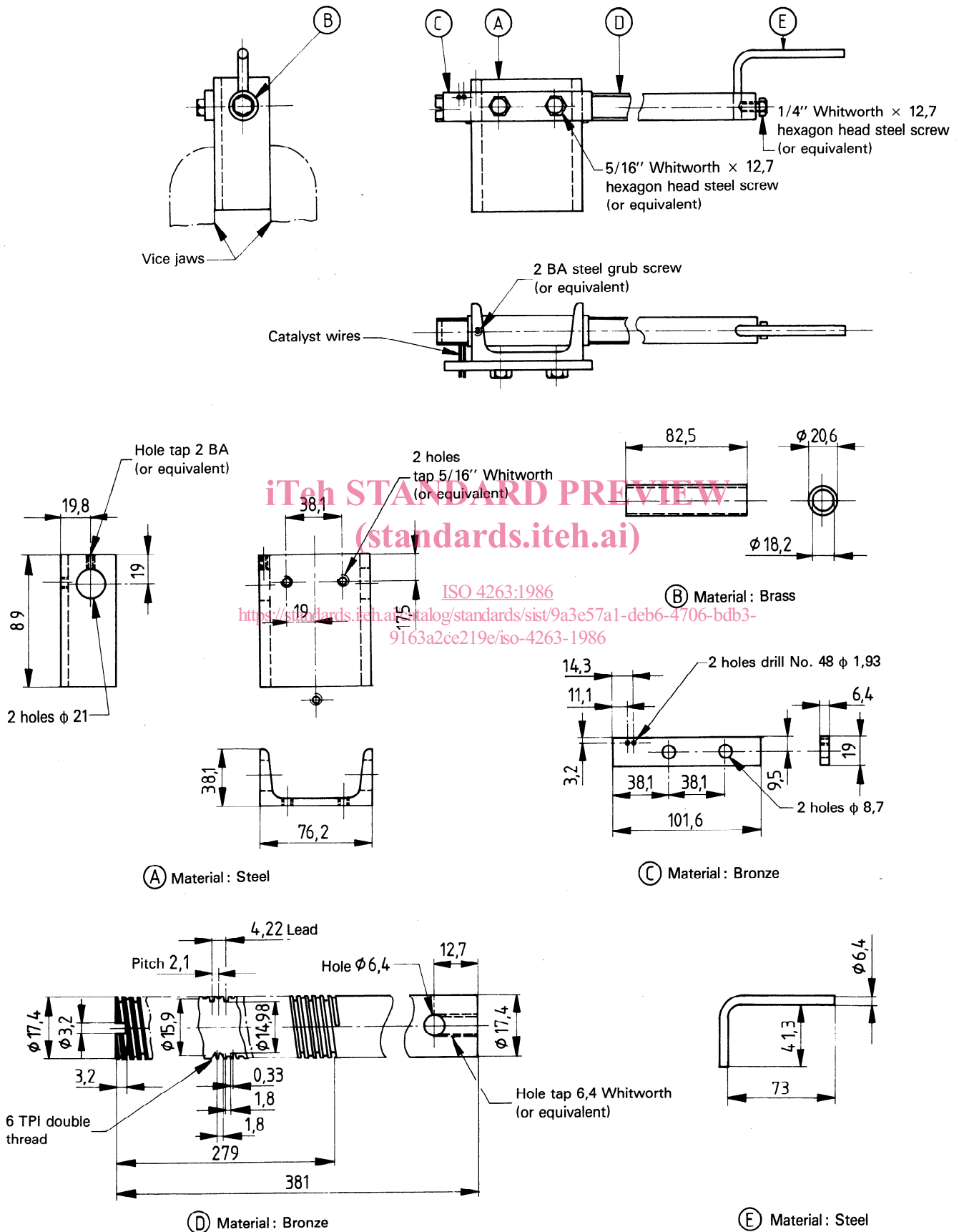
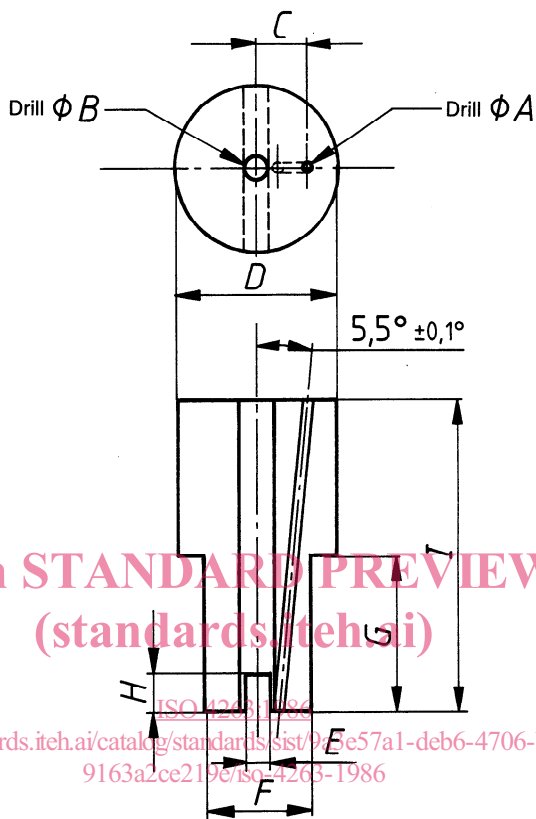

Figure 3 — Mandrel for winding catalyst coils



<https://standards.iteh.ai/catalog/standards/sist/9e57a1-deb6-4706-bdb3-9163a2ce219c/iso-4263-1986>

	Dimension mm	Tolérance mm
A	2,4	0,1
B	7,5	0,1
C	12,7	0,25
D	38,0	0,50
E	6,0	0,50
F	25,4	0,25
G	38,0	0,50
H	9,5	0,50
I	76,0	0,50

Figure 4 — Sampling tube holder