



Designation: A970/A970M – 18

Standard Specification for Headed Steel Bars for Concrete Reinforcement¹

This standard is issued under the fixed designation A970/A970M; the number immediately following the designation indicates the year of original adoption or, in the case of revision, the year of last revision. A number in parentheses indicates the year of last reapproval. A superscript epsilon (ϵ) indicates an editorial change since the last revision or reapproval.

1. Scope*

1.1 This specification covers deformed steel reinforcing bars in cut lengths, with a head attached to one or both ends, for concrete reinforcement. Heads are forge-formed, machined from bar stock, or cut from plate. Attachment can be accomplished through:

- 1.1.1 Welding;
- 1.1.2 Integrally hot forging of a head from the reinforcing bar end;
- 1.1.3 Internal threads in the head mating to threads on the bar end;
- 1.1.4 Cold-swaging an externally threaded coupling sleeve onto the reinforcing bar;
- 1.1.5 Cold-extruding an external coupling sleeve onto the reinforcing bar;
- 1.1.6 Cold-swaging an external coupling sleeve or headed sleeve onto the reinforcing bar;
- 1.1.7 Attaching a coupling sleeve to the end of the reinforcing bar by means of the means of a ferrous-filler medium; or
- 1.1.8 Separate threaded nut to secure the head to the bar.

NOTE 1—The requirements of this specification are only applicable to headed bars where the attachment of the head is accomplished by one of the methods listed in 1.1.

1.2 Limitations on head dimensions and on obstructions and interruptions of bar deformations on the non-planar features on the bearing face of the head are presented in Annex A1. The requirements in Annex A1 only apply when specified by the purchaser (see 4.2.3).

1.3 This specification is applicable for orders in either inch-pound units as Specification A970 or SI units as Specification A970M.

1.4 The values stated in either inch-pound units or SI units are to be regarded separately as standard. Within the text, the SI units are shown in brackets. The values stated in each system may not be exact equivalents; therefore, each system

shall be used independently of the other. Combining values from the two systems may result in non-conformance with the specification.

1.5 *This standard does not purport to address all of the safety concerns, if any, associated with its use. It is the responsibility of the user of this standard to establish appropriate safety, health, and environmental practices and determine the applicability of regulatory limitations prior to use.*

1.6 *This international standard was developed in accordance with internationally recognized principles on standardization established in the Decision on Principles for the Development of International Standards, Guides and Recommendations issued by the World Trade Organization Technical Barriers to Trade (TBT) Committee.*

2. Referenced Documents

- 2.1 *ASTM Standards:*²
 - A370 Test Methods and Definitions for Mechanical Testing of Steel Products
 - A615/A615M Specification for Deformed and Plain Carbon-Steel Bars for Concrete Reinforcement
 - A700 Guide for Packaging, Marking, and Loading Methods for Steel Products for Shipment
 - A706/A706M Specification for Deformed and Plain Low-Alloy Steel Bars for Concrete Reinforcement
- 2.2 *AWS Standards:*³
 - AWS C6.1 Recommended Practices for Friction Welding
 - AWS D1.4/D1.4M Structural Welding Code - Reinforcing Steel
- 2.3 *U.S. Military Standard:*⁴
 - MIL-STD-129 Marking for Shipment and Storage
- 2.4 *U.S. Federal Standard:*⁴
 - Fed. Std. No. 123 Marking for Shipment (Civil Agencies)

¹ This specification is under the jurisdiction of ASTM Committee A01 on Steel, Stainless Steel and Related Alloys and is the direct responsibility of Subcommittee A01.05 on Steel Reinforcement.

Current edition approved Sept. 1, 2018. Published September 2018. Originally approved in 1997. Last previous edition approved in 2017 as A970/A970M – 17. DOI: 10.1520/A0970_A0970M-18.

² For referenced ASTM standards, visit the ASTM website, www.astm.org, or contact ASTM customer service at service@astm.org. For *Annual Book of ASTM Standards* volume information, refer to the standard's Document Summary page on the ASTM website.

³ Available from American Welding Society (AWS), 550 NW LeJeune Rd., Miami, FL 33126, <http://www.aws.org>.

⁴ Available from DLA Document Services, Building 4/D, 700 Robbins Ave., Philadelphia, PA 19111-5094, <http://quicksearch.dla.mil>.

*A Summary of Changes section appears at the end of this standard

2.5 *ACI Standard*:⁵

ACI 318 Building Code Requirements for Structural Concrete

3. Terminology

3.1 *Definitions of Terms Specific to This Specification:*

3.1.1 *cold-extruded coupling sleeve headed bar, n*—steel reinforcing bar that has the head(s) attached by means of a coupling sleeve that is axially cold-extruded onto the bar end(s).

3.1.1.1 *Discussion*—Similar to cold-swaged threaded coupling sleeve headed bar. This extruded coupling sleeve consists of an axially extruded sleeve portion that engages the deformed reinforcing bar and a pre-threaded integral stud with external threads, which match threads internal to the head(s). The head is screwed onto the mating threads on the extruded coupling sleeve. The threads may be parallel or tapered.

3.1.2 *cold-swaged external sleeve headed bar, n*—steel reinforcing bar that has the head(s) attached by means of a coupling sleeve that is cold-swaged onto the bar end(s).

3.1.2.1 *Discussion*—Similar to cold-swaged threaded coupling sleeve headed bar. This sleeve is a combination of a tubular sleeve portion extending in front of the head, and an integral one-piece head immediately adjacent to the cold-swaged sleeve. The sleeve and head assembly is attached to the deformed reinforcing bar by cold-swaging the tubular sleeve portion to the bar with multiple crimps from a hydraulic swaging tool and die, up to the face of the head section.

3.1.3 *cold-swaged headed sleeve headed bar, n*—steel reinforcing bar that has the head(s) attached by means of a sleeve that is cold-swaged onto the bar end(s).

3.1.3.1 *Discussion*—Similar to cold-swaged external coupling sleeve headed bar. This sleeve is a one-piece unit with an integral cold-swaged head. The head assembly is attached to the deformed reinforcing bar by cold-swaging the tubular sleeve to the bar with a hydraulic swaging tool and die.

3.1.4 *cold-swaged threaded coupling sleeve headed bar, n*—steel reinforcing bar that has the head(s) attached by means of a coupling sleeve that is cold-swaged onto the bar end(s).

3.1.4.1 *Discussion*—The coupling sleeve assembly is attached to the deformed reinforcing bar by cold-swaging the tubular sleeve portion to the bar with multiple crimps from a hydraulic swaging tool and die, up to the face of the pre-threaded section. This coupling sleeve is pre-threaded with external threads, which match threads internal to the head(s). The head is screwed onto the mating threads on the coupling sleeve. The threads may be parallel or tapered.

3.1.5 *ferrous-filler coupling sleeve headed bar, n*—steel reinforcing bar that has the head(s) attached by means of a coupling sleeve mechanically attached to the bar via an interlock of ferrous-filler material and the bar deformations.

3.1.5.1 *Discussion*—The ferrous-filler material is cast into the coupling sleeve. A variation includes a separate internally threaded nut secured to the threaded bar end or attached via welding a plate to the end of a prepared coupling sleeve.

3.1.6 *forged headed bar, n*—steel reinforcing bar that has the head(s) integrally forged.

3.1.7 *head, n*—round, elliptical, or rectangular shape used to anchor a steel reinforcing bar in concrete.

3.1.8 *net bearing area, n*—gross cross-sectional area of the head minus the nominal cross-sectional area of the deformed reinforcing bar.

3.1.9 *threaded headed bar, n*—steel reinforcing bar that has the head(s) attached using tapered or straight threads internal to the head or by a separate internally threaded nut securing the head to the threaded bar end.

3.1.10 *welded headed bar, n*—steel reinforcing bar that has the head(s) welded.

4. Ordering Information

4.1 Orders for headed steel bars for concrete reinforcement under this specification shall contain following information:

- 4.1.1 Quantity;
- 4.1.2 Type of product: welded, forged, cold-swaged, cold-extruded, ferrous metal-filled sleeved, or threaded headed bars;
- 4.1.3 Reinforcing bar specification and year of issue;
- 4.1.4 Bar size designation;
- 4.1.5 Deformed reinforcing bars;
- 4.1.6 Head geometry, including thickness, diameter or height and width of the head;
- 4.1.7 Number of heads per bar length;
- 4.1.8 Length of bar assembly; and
- 4.1.9 ASTM designation and year of issue.

4.2 The purchaser shall have the option to specify additional requirements, including, but not limited to, the following:

- 4.2.1 Packaging (15.1, 15.2);
- 4.2.2 Bend testing of welded headed bars in sizes No. 11, 14, and 18 [36, 43, and 57] (6.4.1);
- 4.2.3 Optional requirements of Annex A1, if applicable;
- 4.2.4 Optional copy of material test report (6.1, 13.2); and
- 4.2.5 Other special requirements, if any.

5. Material and Manufacture

5.1 *Reinforcing Bars*—For welded headed bars, the reinforcing bars shall conform to Specification A706/A706M. For forged non-welded headed bars, the reinforcing bars shall conform to Specification A615/A615M or A706/A706M, as specified by the purchaser.

5.2 *Heads:*

5.2.1 The head material shall be selected by the manufacturer.

5.3 The head dimensions shall be provided by the purchaser in the order. Head dimensions shall define the head geometry including thickness, diameter, or height and width of the head (Fig. 1). Alternate head dimensions supplied by the manufacturer shall be permitted if agreed to in advance by the purchaser. The manufacturer shall furnish documentation to the purchaser, in the form of calculations or test reports, or both, that confirms the suitability of alternate head dimensions for the intended application.

NOTE 2—Alternate head dimensions resulting in a net bearing area less

⁵ Available from American Concrete Institute (ACI), P.O. Box 9094, Farmington Hills, MI 48333-9094, <http://www.concrete.org>.

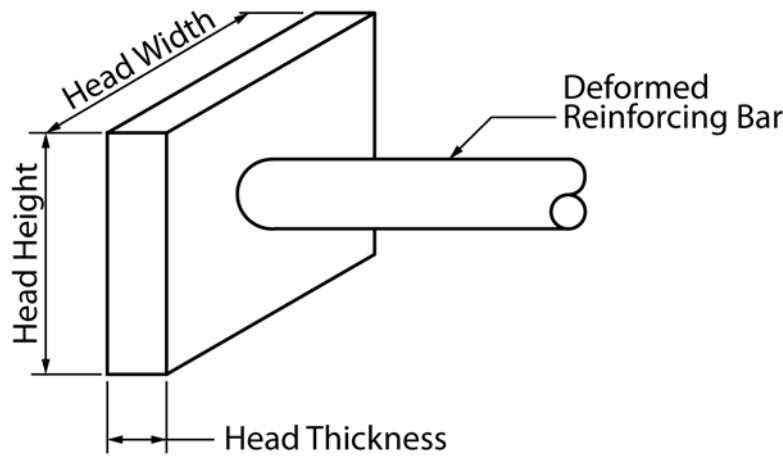

FIG. 1 Headed Reinforcing Bar

than four times the nominal cross-sectional area of the deformed reinforcing bar are not suitable for use in construction projects governed by certain consensus building codes and design standards (see 5.4 and Note 3).

5.4 When specified by the purchaser in the purchase order or contract as a class HA headed bar, head dimensions shall meet the requirements of Annex A1.

NOTE 3—Some methods of attachment, as defined in Section 3 of this specification, do not meet the requirements on obstructions as prescribed in Annex A1. The requirements for head dimensions, limitations to reinforcing bar deformation interruptions and the size of obstruction allowances provided in Annex A1 are mandated by certain consensus building codes and design standards, for example, "Building Code Requirements for Structural Concrete (ACI 318)." Heads with obstructions that do not conform to Annex A1 may not be permitted for use by certain building codes and design standards, such as ACI 318.

5.5 *Welding*—A welding procedure conforming to AWS D1.4/D1.4M shall be used for all required production welding of the head to the bar, except for friction welding that shall conform to AWS C6.1 in conjunction with the manufacturer's QA/QC procedures.

5.6 *Forging*—For integrally forged headed bars, the heads shall be produced by deforming the bar ends in a hot-forging process.

5.7 *Threading*:

5.7.1 Threads on bars shall be either tapered or straight. The head shall either thread onto the bar directly, or it shall be held on the bar end by a nut and counter nut. Thread specifications and standards shall be selected by the manufacturer.

5.7.2 The out-of-roundness in the as-rolled reinforcing bar shall be evaluated so that the manufacturer's minimum thread dimensions are maintained.

5.7.3 It shall be permissible to hot- or cold-roll, or machine cut, threads into the surface of the bar and heads at the option of the manufacturer.

6. Mechanical Test and Performance Requirements

6.1 Headed bars shall be subjected to mechanical tests to verify production method and product quality prior to manufacture. Mechanical testing also shall be performed at intervals during production of the assembly.

6.2 Tensile Tests:

6.2.1 Tensile testing of the headed bar assembly shall be performed in accordance with the requirements described in Test Methods and Definitions A370. The failure mode shall be reported as partial or total fracture of the bar, the head, or the head-to-bar connection.

6.2.2 *Specimen Preparation*—Tensile test specimens shall be the full cross-section of the bar with a head attached to one end of the reinforcing bar. The minimum length of the test specimen shall be the greater of 10 in. [250 mm] or ten times the nominal diameter of the bar. The test specimen shall be placed in the testing machine with the head supported to prevent movement and bending of the head. Provisions shall be made for clearance between the support and any weld or forming material on the reinforcing bar-to-head connection. The opposite bar end of the bar, without a head attached, shall be gripped by the testing machine and loaded to failure.

6.3 Tensile Requirements:

6.3.1 *Tensile Properties*—The tensile properties of the test specimen shall conform to one of the following classes:

6.3.1.1 *Class A*—Develop the minimum specified tensile strength of the reinforcing bar.

6.3.1.2 *Class B*—Develop the minimum specified tensile strength and the minimum specified elongation of the reinforcing bar.

NOTE 4—Reference the requirements of Specifications A615/A615M and A706/A706M for minimum reinforcing bar tensile properties. Class A has been introduced for applications that require the development of the minimum tensile strength of the reinforcing bar. The Class B criteria requires the head and the head-to-bar connection to meet or exceed the minimum specified tensile strength and the minimum specified elongation requirements of the reinforcing bar. In the previous criteria, the failure of the head or the head-to-bar connection within the attachment region was cause for rejection.

6.4 Bend Test Requirements:

6.4.1 Only welded headed bars in sizes No. 3 to 10 [10 to 32] shall be subject to bend testing. Bend testing of welded headed bars in sizes No. 11, 14, and 18 [36, 43, and 57] shall be subject to agreement between the purchaser and manufacturer.

NOTE 5—Serious safety issues may be involved in performing bend

TABLE 1 Bend Test Requirements

Bar Designation No.	Mandrel Diameter
3, 4, and 5 [10, 13, and 16]	3d ^A
6, 7, and 8 [19, 22, and 25]	4d
9, 10, and 11 [29, 32, and 36]	6d
14 and 18 [43 and 57]	8d

^A d = nominal diameter of bar

tests on welded headed bars in sizes No. 11, 14, and 18 [36, 43, and 57]. Thus, 6.4 requires such bend testing to be subject to agreement between the purchaser and manufacturer.

6.4.2 *Procedure*—The test specimen shall be bent around a mandrel of suitable diameter to an angle of at least 90° with no observed partial or total fracture of the head, the bar, or the head-to-bar connection.

6.4.3 *Bend Test Mandrel*—The mandrel shall be placed so as to directly bend the welded region. The required mandrel dimensions for bend testing are prescribed in Table 1. The centerline of the bend test mandrel shall be placed at the intersection of the reinforcing bar and the weld, as shown in Fig. 2.

6.4.4 *Specimen Preparation*—Bend test specimens shall be the full cross-section of the bar with a head attached to one end of the deformed reinforcing bar. Where the welded head interferes with placement of the bend test mandrel, sufficient head material and any excess material associated with the welding process shall be removed along one edge of the deformed reinforcing bar to provide a flat surface on the specimen for the bend mandrel. This preparation shall ensure that the contact point of the bend mandrel is directly at the base of the reinforcing bar diameter as shown in Fig. 2.

7. Frequency of Testing

7.1 Number of Tests:

7.1.1 *Pre-Production*—Prior to production, a testing program shall be undertaken that includes two bend tests for welded headed bars and two tensile tests for all headed bars. The tests shall be repeated for each combination of head and bar material specification, grade or type, or head attachment method.

NOTE 6—The bend test is used to ensure that no weak points existed in the weld at the head-to-bar connection. Other head-to-bar connections are not subject to this test due to the mechanical nature of those head-to-bar connections.

7.1.2 *Production Sampling and Testing of Headed Bars*—It shall be permissible to use either the tensile test prescribed in 6.3, or the bend test prescribed in 6.4 to verify the production method and product quality of headed bar. A minimum of two specimens shall be sampled and tested for each production shift or period. One test of a headed bar at the start and one test at the end of each 8-h production period or less than 8-h production period or at random intervals during the production period shall be conducted. Sampling shall be conducted at the location where the head is permanently attached to the reinforcing bar in its final form, unless otherwise agreed to by the purchaser and the manufacturer at the time of purchase.

NOTE 7—Headed bars as defined in this specification can be produced from single or multiple components. It is the intent of this specification to

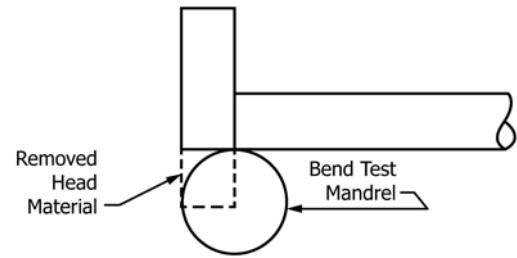

FIG. 2 Bend Test Specimen Mandrel Configuration

require production sampling at the location where final assembly occurs.

7.1.2.1 In the event different heats of head or bar material, or both, within the same material specification are used to produce headed bar assemblies during a production run, a minimum of two tensile tests in accordance with 6.3 or two bend tests in accordance with 6.4 shall be conducted to verify the production method, product quality, and head attachment method prior to continuing production.

7.1.2.2 *Test Specimen Length*—The test specimen length shall be sufficient to accommodate a minimum of 8 in. [200 mm] of free bar length between the grips of the tensile testing machine holding the reinforcing bar and the bearing face of the head. Lot traceability shall be maintained for the specimen.

7.2 Retests:

7.2.1 *Pre-Production*—Any identified procedural or performance deficiencies shall be corrected and pre-production testing repeated until the tensile and bend test results meet the performance requirements of this specification.

7.2.2 *Production*—For welded headed bars, when partial or total fracture(s) of the bend or tensile test specimens occur(s) in the weld, the production lot shall be rejected and a retest shall be conducted as shown in 7.2.2.1 or 7.2.2.3. During production tests of headed bars, if any tensile test specimen fails to not meet the requirements for tensile properties in 6.3.1, the production lot shall be retested as shown in 7.2.2.1. For threaded components used to assemble the headed bars, if thread dimensions are found not to meet the manufacturer's practices for the threads, the production lot shall be rejected.

7.2.2.1 If the result of a tension test fails to meet the requirements for tensile properties in 6.3.1, then a retest shall be allowed. Two specimens taken at random from the production lot shall be tested during a retest. Both specimens shall meet the tension test requirements of Section 6, or the production lot shall be rejected.

7.2.2.2 If any test specimen fails because of mechanical reasons, such as failure of the testing equipment or from flaws caused by specimen preparation, shipment, or other damage unrelated to manufacturing or testing, it shall be discarded and another specimen from the same production lot substituted.

7.2.2.3 If a bend test fails for reasons other than mechanical reasons or flaws in the specimen, as described in 7.2.2.2, a retest shall be permitted on two random specimens from the same production lot. If the results of both test specimens meet the specified requirements, the lot shall be accepted.

8. Finish

8.1 Rust, surface irregularities, or mill scale shall not be cause for rejection, provided the dimensions, cross-sectional

area, and tensile properties of a hand wire brushed specimen are not less than the requirements of this specification.

9. Inspection

9.1 The inspector representing the purchaser shall have free entry while work on the contract of the purchaser is being performed to the parts of the manufacturer's facilities that concern manufacture of the material ordered. The manufacturer shall afford the inspector reasonable access to the facilities to satisfy the inspector that the materials and procedures are in accordance with this specification. Inspection at the place of manufacture shall be conducted so as not to interfere unnecessarily with the operation of the manufacturer's facilities.

9.2 *For Government Procurement Only*—Except as otherwise specified in the contract, the manufacturer shall be responsible for the performance of inspection and test requirements specified herein, unless otherwise agreed by the purchaser at the time of purchase, and shall use the purchaser's own or other suitable facilities for the performance of the inspection and test requirements specified herein.

10. Rejection

10.1 The purchaser shall have the right to perform any of the inspections and tests as set forth in this specification as deemed necessary. Unless otherwise specified, any rejection based on tests made in accordance with this specification shall be reported to the manufacturer within five working days from the receipt of samples by the purchaser.

10.2 Material that does not meet the requirements of this specification subsequent to its acceptance at the manufacturer's facilities shall be subject to rejection, and the manufacturer shall be promptly notified.

11. Rehearing

11.1 Samples tested in accordance with this specification that represent rejected material shall be preserved for two weeks from the date rejection is reported to the manufacturer. In case of dissatisfaction with the results of the test, the manufacturer shall make claim for a rehearing within that time.

12. Documentation

12.1 A manufacturer's product certificate shall accompany headed bars when they are shipped from the manufacturer's facilities.

13. Test Reports

13.1 For welded headed bars, a test report shall be furnished by the manufacturer containing on a per heat basis the chemical analysis of the bar and of the head material, including all elements represented in the carbon equivalent formula of Specification **A706/A706M**, in addition to phosphorus and sulfur.

13.2 A test report shall be required of the manufacturer for the production of headed bar assemblies as described in Section 6, including the failure mode. A copy of the test report shall be provided to the purchaser upon request.

13.3 A material test report, certificate of inspection, or similar document printed from or used in electronic form from an electronic data interchange (EDI) transmission shall be regarded as having the same validity as a counterpart printed in the certifier's facility. The content of the EDI transmitted document shall meet the requirements of the invoked ASTM standard(s) and conform to any existing EDI agreement between the purchaser and the manufacturer. Notwithstanding the absence of a signature, the organization submitting the EDI transmission is responsible for the content of the report.

NOTE 8—The industry definition as invoked here is: EDI is the computer-to-computer exchange of business information in a standard format such as ANSI ASC X12.

14. Marking

14.1 Each manufacturer shall identify the symbols of their marking system.

14.2 All headed bars manufactured under this specification shall be identified by a distinguishing set of marks legibly stamped onto the flat outer side of the head, away from the bar, to denote the following:

14.2.1 *Point of Origin*—Letter(s) or symbol(s) established as the manufacturer's designation.

14.2.2 *Type of Headed Reinforcing Bar*—Letter *T* indicating that the headed bar was manufactured to this specification.

15. Packaging

15.1 When specified in the purchase order, packaging shall be in accordance with the procedures in Practices **A700**.

15.2 *For Government Procurement Only*—When specified in the contract or order and for direct procurement by or direct shipment to the U.S. government, marking for shipment, in addition to requirements specified in the contract or order, shall be in accordance with MIL-STD-129 for military agencies and Fed. Std. No. 123 for civil agencies.

16. Keywords

16.1 carbon-steel reinforcing bars; cold-extruded threaded headed reinforcing bars; cold-swaged coupling sleeve headed reinforcing bars; cold-swaged external sleeve headed reinforcing bars; cold-swaged headed sleeve reinforcing bars; concrete reinforcement; deformations (protrusions); ferrous-filled headed reinforcing bars; headed reinforcement; headed reinforcing bars; integrally-forged headed reinforcing bars; low-alloy steel reinforcing bars; threaded headed reinforcing bars; welded headed reinforcing bars

A1. REQUIREMENTS FOR CLASS HA HEAD DIMENSIONS

INTRODUCTION

The following requirements shall apply only when specified in the purchase order or contract. When specified, this Annex A1 replaces 5.3, 6.3.1.1, and 14.2.2 with the following.

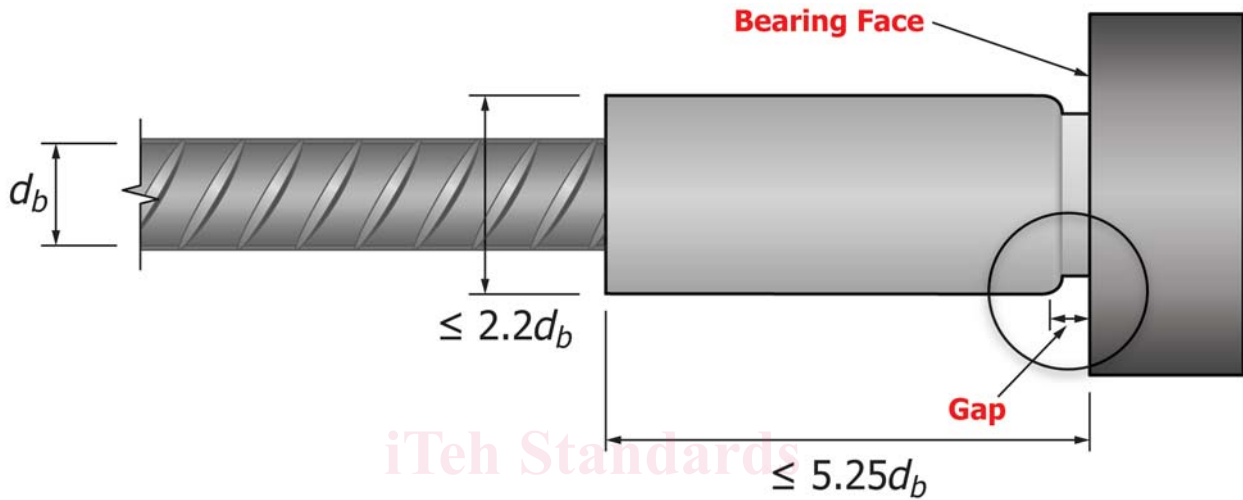

FIG. A1.1 Maximum Dimensions and Non-Planar Features of Obstruction or Interruptions of Bar Deformations

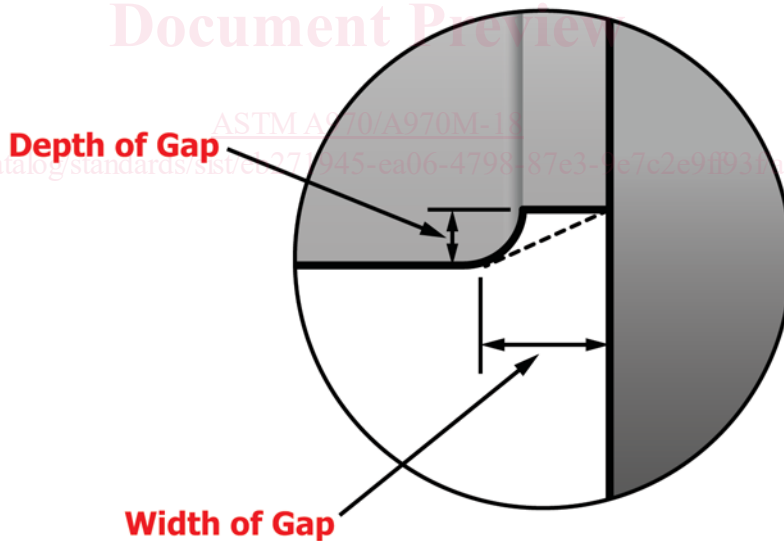

FIG. A1.2 Details of Gap in Obstruction Adjacent to Head

A1.1 Replacement Requirements for 5.3

A1.1.1 Head dimensions for headed bars conforming to Class HA shall be provided by the purchaser in the purchase order.

A1.1.1.1 Head dimensions shall define the head geometry including thickness, diameter or height and width of the head (Fig. 1).

A1.1.1.2 Class HA head dimensions shall comply with A1.1.1.3 through A1.1.1.7.

A1.1.1.3 The net bearing area of a bar without an obstruction meeting the requirements of this annex is the gross area of the head minus the area of the deformed reinforcing bar and shall not be less than four times the nominal cross-sectional area of the bar.