



Designation: ~~F837 – 13^{e1}~~ **F837 – 13 (Reapproved 2018)**

Standard Specification for Stainless Steel Socket Head Cap Screws¹

This standard is issued under the fixed designation F837; the number immediately following the designation indicates the year of original adoption or, in the case of revision, the year of last revision. A number in parentheses indicates the year of last reapproval. A superscript epsilon (ϵ) indicates an editorial change since the last revision or reapproval.

This standard has been approved for use by agencies of the U.S. Department of Defense.

^{e1} NOTE—S9 Mechanical Property Requirements was editorially corrected in March 2014.

1. Scope*

1.1 This specification covers the chemical and mechanical requirements for stainless steel inch socket head cap screw (SHCS) with nominal thread 0.060 through 1.500 in. and intended for use in applications requiring general corrosion resistance.

1.2 Three groups of stainless steel alloys are covered, austenitic Group 1 and 2 and martensitic Group 5.

1.3 Four property conditions are covered: austenitic Alloy Groups 1 and 2 in an annealed condition (AF) at 85 ksi maximum, in two cold worked conditions (CW) at 80 ksi minimum, (CW1) at 102 ksi minimum, and martensitic Alloy Group 5 in a heat treated condition (HT) at 160 ksi minimum.

1.4 The values stated in inch-pound units are to be regarded as standard. No other units of measurement are included in this standard.

1.5 The following precautionary caveat pertains only to the test method portion, Section 13, of this specification: *This standard does not purport to address all of the safety concerns, if any, associated with its use. It is the responsibility of the user of this standard to establish appropriate safety, health, and environmental practices and determine the applicability of regulatory limitations prior to use.*

1.6 *This international standard was developed in accordance with internationally recognized principles on standardization established in the Decision on Principles for the Development of International Standards, Guides and Recommendations issued by the World Trade Organization Technical Barriers to Trade (TBT) Committee.*

2. Referenced Documents

- 2.1 ¹ASTM Standards:²
- A262 Practices for Detecting Susceptibility to Intergranular Attack in Austenitic Stainless Steels
 - A342/A342M Test Methods for Permeability of Weakly Magnetic Materials
 - A380 Practice for Cleaning, Descaling, and Passivation of Stainless Steel Parts, Equipment, and Systems
 - A555/A555M Specification for General Requirements for Stainless Steel Wire and Wire Rods
 - A751 Test Methods, Practices, and Terminology for Chemical Analysis of Steel Products
 - A967 Specification for Chemical Passivation Treatments for Stainless Steel Parts
 - D3951 Practice for Commercial Packaging
 - E18 Test Methods for Rockwell Hardness of Metallic Materials
 - E92 Test Methods for Vickers Hardness and Knoop Hardness of Metallic Materials
 - E384 Test Method for Microindentation Hardness of Materials
 - F606 Test Methods for Determining the Mechanical Properties of Externally and Internally Threaded Fasteners, Washers, and Rivets (Metric) F0606_F0606M
 - F788/F788M Specification for Surface Discontinuities of Bolts, Screws, and Studs, Inch and Metric Series
 - F1470 Practice for Fastener Sampling for Specified Mechanical Properties and Performance Inspection

¹ This specification is under the jurisdiction of ASTM Committee F16 on Fasteners and is the direct responsibility of Subcommittee F16.04 on Nonferrous Fasteners. Current edition approved Nov. 1, 2013. Published September 1, 2013. Originally approved in 1988. Last previous edition approved in 2008 as F837 – 08. F837 – 13^{e1}. DOI: 10.1520/F0837-13E01.10.1520/F0837-13R18.

² For referenced ASTM standards, visit the ASTM website, www.astm.org, or contact ASTM Customer Service at service@astm.org. For Annual Book of ASTM Standards volume information, refer to the standard's Document Summary page on the ASTM website.

*A Summary of Changes section appears at the end of this standard

2.2 ASME Standard:

ASME B18.3 Socket Cap, Shoulder, and Set Screws—Inch Series³

2.3 JIS Standard:⁴

JIS G 4311 Heat Resisting Steel Bar and Wire Rods³

3. Classification

3.1 The austenitic stainless steel socket head cap screw shall be designated F837 Group 1 or 2 Condition AF, F837 Group 1 or 2 Condition CW, or F837 Group 1 or 2 Condition CW1.

3.2 The martensitic stainless steel socket head cap screw shall be designated F837 Group 5 Condition HT.

4. Ordering Information

4.1 Orders for socket head cap screws under this specification shall include:

4.1.1 Quantity (number of pieces of each item).

4.1.2 Name of the item (socket head cap screws, SHCS).

4.1.3 Size (nominal diameter, thread pitch, thread class, screw length) or part number.

4.1.4 Alloy Group (see 7.1) and Condition (Group 1 or 2 AF, Group 1 or 2 CW, Group 1 or 2 CW1, or Group 5 HT).

4.1.5 ASTM specification and year of issue. When year of issue is not specified, fasteners shall be furnished to the latest issue.

4.1.6 Supplementary requirements, if any, (see S1 through S7).

4.1.7 Additional special requirements, if any, to be specified on the purchase order:

4.1.7.1 Forming (see 5.1).

4.1.7.2 Threading (see 5.2).

4.1.7.3 Surface finish (see 11.1).

4.1.7.4 Alloy selection (see 7.2).

4.1.7.5 Test report (see 12.2).

4.1.7.6 Additional testing (see 12.3).

4.1.7.7 Inspection (see 14.1).

4.1.7.8 Rejection (see 15.1).

4.1.7.9 Certification (see 16.1).

4.1.7.10 Special packaging requirements (see 18.3).

4.1.7.11 Supplementary requirements as needed.

5. Materials and Manufacture

5.1 *Heads*—Unless otherwise specified the head and socket recess of the screw may be hot forged, cold forged, or machined at the option of the manufacturer. Users requiring cold forged heads should specify Supplementary Requirements S6.

5.2 *Threads*—Unless otherwise specified, screws in sizes up to 1.00 in. inclusive and product lengths up to 6 in. inclusive, shall have threads formed by rolling, except by special agreement with the purchaser. Larger products may be rolled, cut, or ground at the option of the manufacturer.

6. Heat Treatment

6.1 Austenitic alloys Group 1 or 2 Condition AF screws, following manufacture, shall be annealed by heating to $1900 \pm 50^{\circ}\text{F}$ to obtain maximum corrosion resistance and minimum permeability. The screws shall be held for a sufficient time at temperature and then cooled at a rate sufficient to prevent precipitation of the carbide and to provide the properties specified in Table 1.

6.2 When Condition CW or CW1 is specified, the austenitic alloys shall be annealed as specified in 6.1 generally by the raw material manufacturer, then cold worked to develop specific properties.

6.3 Martensitic alloy Group 5 Condition HT screws shall be hardened and tempered by heating to $1800 \pm 50^{\circ}\text{F}$ sufficient for austenitization, holding for at least ½ h, rapid air or oil quenching, reheating to 525°F minimum and holding for at least 1 h and then air cooling to provide the properties specified in Table 1.

7. Chemical Properties

7.1 It is the intent of this specification that screws shall be ordered by alloy group and condition. The chemical composition of the screw material shall conform to the requirements of Table 2.

³ Available from Global Engineering Documents, 15 Inverness Way, East Englewood, CO 80112-5704, <http://www.global.ihc.com>; American Society of Mechanical Engineers (ASME), ASME International Headquarters, Two Park Ave., New York, NY 10016-5990, <http://www.asme.org>.

⁴ Available from Japanese Standards Association (JSA), Mita MT Bldg., 3-13-12 Mita, Minato-ku, Tokyo 108-0073, Japan, <http://www.jsa.or.jp>.

TABLE 1 Mechanical Property Requirements

Alloy Group	Condition	Alloy Mechanical Property Marking	Nominal Thread Diameter ^A	Full-Size Product		Machine Specimen			Core Hardness ^B	
				Tensile Strength, ksi	Minimum Extension ^C	Tensile Strength, ksi	Yield Strength, ksi	Minimum Elongation, %	Vickers	Rockwell
1	AF	F837A	0.060–1.500	85 max	0.6D	85 max	55 max	40	210 max	95 HRB max
1	CW	F837B	0.060–0.750	80 min	0.4D	80 min	40 min	25	150 min	50 HRA min
1	CW1	F837C	0.060–0.750	102 min	0.4D	87 min	65 min	20	220 min	59 HRA min
2	AF	F837D	0.060–1.500	85 max	0.6D	85 max	55 max	40	210 max	95 HRB max
2	CW	F837E	0.060–0.750	80 min	0.4D	80 min	40 min	25	150 min	50 HRA min
2	CW1	F837F	0.060–0.750	102 min	0.4D	87 min	65 min	20	220 min	59 HRA min
5	HT	F837G	0.060–0.190	180 min	350–423	36–43 HRC
5	HT	F837H	0.250–1.500	180 min	0.2D	160 min	120 min	12	350–423	36–43 HRC

^A For CW and CW1 condition fasteners with nominal thread diameter larger than 0.750 in., the mechanical properties and marking shall be agreed upon between the user and manufacturer.

^B Core hardness is only required when full-size product tensile testing cannot be accomplished.

^C D denotes nominal thread size.

TABLE 2 Chemical Requirements

Alloy Group	UNS Designation	Alloy	Composition, % maximum except as shown								
			Carbon	Manganese	Phosphorus	Sulfur	Silicon	Chromium	Nickel	Copper	Molybdenum
Austenitic Alloys											
1	S30300	303 ^A	0.15	2.00	0.20	0.15 min	1.00	17.0 to 19.0	8.0 to 10.0	...	0.60 max ^B
1	S30400	304	0.08	2.00	0.045	0.030	1.00	18.0 to 20.0	8.0 to 10.5	1.00	...
1	S30403	304L	0.030	2.00	0.045	0.030	1.00	18.0 to 20.0	8.0 to 12.0	1.00	...
1	S30500	305	0.12	2.00	0.045	0.030	1.00	17.0 to 19.0	10.5 to 13.0	1.00	...
1	S38400	384	0.08	2.00	0.045	0.030	1.00	15.0 to 17.0	17.0 to 19.0
1	S20300	XM1 ^A	0.08	5.0 to 6.5	0.040	0.18 to 0.35	1.00	16.0 to 18.0	5.0 to 6.5	1.75 to 2.25	0.50 max ^B
1	S30430	18-9LW	0.10	2.00	0.045	0.030	1.00	17.0 to 19.0	8.0 to 10.0	3.00 to 4.00	...
1	S30433	302HQ	0.03	2.00	0.045	0.030	4.00	17.0 to 19.0	8.0 to 10.0	3.0 to 4.0	...
1	...	304J3 ^C	0.08	2.00	0.045	0.030	1.00	17.0 to 19.0	8.0 to 10.5	1.00 to 3.00	...
2	S31600	316	0.08	2.00	0.045	0.030	1.00	16.0 to 18.0	10.0 to 14.0	...	2.0 to 3.0
2	S31603	316L	0.03	2.00	0.045	0.030	1.00	16.0 to 18.0	10.0 to 14.0	...	2.0 to 3.0
Martensitic Alloys											
5	UNS41000	410	0.15	1.00	0.040	0.030	1.00	11.5 to 13.5

^A Free machining grades are not recommended for forged product. These grades may be furnished only when approved by the purchaser.

^B At manufacturer's option, determined only when intentionally added.

^C 304J3 from JIS standard G 4311.

ASTM F837-13(2018)

<https://standards.iteh.ai/catalog/standards/sist/cbb10e43-5d00-47f8-9c89-13f66943317/astm-f837-132018>

7.2 Unless otherwise specified in the inquiry and purchase order (see Supplementary Requirements S2) the choice of an alloy from within a group shall be at the discretion of the fastener manufacturer as required by their method of fastener fabrication and material availability. The specific alloy used by the manufacturer shall be clearly identified on all certification required in the purchase order and shall have chemical composition conforming to the limits specified in **Table 2**.

7.3 When chemical analysis is performed by the purchaser using finished fasteners representing each lot, the chemical contents obtained shall conform to the limits specified in **Table 2** for the specific alloy. Chemical contents shall conform to the tolerances specified in Specification **A555/A555M**.

7.3.1 In the event of discrepancy, a referee analysis as specified in **13.1** of samples for each lot shall be made in accordance with **12.3.1**.

8. Mechanical Properties

8.1 Screws shall be tested in accordance with the mechanical testing requirements for the alloy group and condition nominal thread diameter, length, and specified minimum tensile strength as specified in **Table 3** and shall meet the mechanical requirements specified for that product in **Table 1**.

8.2 For products on which both hardness and tension tests are performed, acceptance based on tensile requirements shall take precedence over low hardness readings (see **Table 4**).

9. Corrosion Resistance

9.1 Carbide Precipitation:

9.1.1 Rod, bar, and wire in the austenitic alloy groups 1 and 2 (not including the free-machining grade 303) used to make fasteners in accordance with this specification shall be capable of passing the test for susceptibility to intergranular corrosion as specified in Practice E of Practice **A262**.

TABLE 3 Mechanical Testing Requirements

Item	Product Length	Hardness		Test Conducted Using Full Size Product		Test Conducted Using Machined Test Specification		
		max	min	Extension	Axial Tensile Strength	Yield Strength 0.2 % offset	Tensile Strength	Elongation
1	≤3 <i>D</i> ^A	<i>B</i>	<i>B</i>
2	>3 <i>D</i> -12 in.	<i>B</i>	...	<i>B</i>	<i>B</i>
3	Over 12 in.	<i>B</i>	...	A	A	B	B	B

^A *D* denotes nominal diameter of product.

^B Denotes mandatory test. In addition, either all tests denoted by A or all tests denoted by B shall be performed. In case of arbitration full size tests, denoted A, shall be decisive.

TABLE 4 Tensile Strength Values for Full-Size Fasteners, lbs

Nominal Size	Stress Area	Alloy Groups 1 and 2			Alloy Group 5
		AF max	CW min	CW1 min	HT min
0.060-80	0.00180	153	144	183	288
0.073-64	0.00263	223	210	267	420
0.073-72	0.00278	236	222	283	444
0.086-56	0.00370	314	296	377	592
0.086-64	0.00394	334	315	401	630
0.099-48	0.00487	414	390	497	779
0.099-56	0.00523	445	418	533	837
0.112-40	0.00604	513	483	615	966
0.112-48	0.00661	562	529	674	1 060
0.125-40	0.00796	676	636	811	1 270
0.125-44	0.00830	706	665	848	1 330
0.138-32	0.00909	772	727	927	1 450
0.138-40	0.01015	862	811	1 035	1 620
0.164-32	0.0140	1 191	1 121	1 429	2 240
0.164-36	0.01474	1 252	1 178	1 502	2 360
0.190-24	0.0175	1 490	1 403	1 788	2 800
0.190-32	0.0200	1 699	1 600	2 039	3 200
0.250-20	0.0318	2 705	2 546	3 246	5 090
0.250-28	0.0364	3 092	2 910	3 710	5 820
0.312-18	0.0524	4 457	4 194	5 348	8 380
0.312-24	0.0580	4 936	4 645	5 923	9 280
0.375-16	0.0775	6 587	6 199	7 904	12 400
0.375-24	0.0878	7 465	7 026	8 958	14 000
0.437-14	0.1063	9 036	8 505	10 843	17 000
0.437-20	0.1187	10 091	9 497	12 109	19 000
0.500-13	0.1419	12 061	11 352	14 474	22 700
0.500-20	0.1599	13 596	12 796	16 315	25 600
0.625-11	0.226	19 210	18 080	23 052	36 200
0.625-18	0.256	21 756	20 477	26 108	41 000
0.750-10	0.334	28 429	26 757	34 115	53 400
0.750-16	0.373	31 702	29 837	38 042	59 700
0.875-9	0.462	39 247	73 900
0.875-14	0.509	43 305	81 400
1.000-8	0.606	51 488	97 000
1.000-12	0.663	56 359	106 000
1.125-7	0.763	64 878	122 000
1.125-12	0.856	72 736	137 000
1.250-7	0.969	82 374	155 000
1.250-12	1.073	91 200	172 000
1.375-6	1.155	98 165	185 000
1.375-12	1.315	111 751	210 000
1.500-6	1.405	119 446	225 000
1.500-12	1.581	134 387	253 000

9.1.2 As stated in Practices **A262**, samples may be subjected to the faster and more severe screening test in accordance with Practice A. Failing Practice A, specimens shall be tested to Practice E and be considered satisfactory if passing Practice E.

10. Dimensions

10.1 Unless otherwise specified, the products shall conform to the requirements of ASME B18.3.

11. Workmanship, Finish, and Appearance

11.1 *Surface Treatment*—Unless otherwise specified, screws shall be cleaned, descaled and passivated in accordance with Practice **A380** or Specification **A967** at the option of the manufacturer.

11.2 The surface discontinuities for these products shall conform to Specification F788/F788M and the additional limitations specified herein.

11.2.1 Forging defects that connect the socket to the periphery of the head are not permissible. Defects originating on the periphery and with a traverse indicating a potential to intersect are not permissible. Other forging defects are permissible provided those located in the bearing area, fillet, and top surfaces shall not have a depth exceeding $0.03 D$ or 0.005 in, whichever is greater. For peripheral discontinuities, the maximum depth may be $0.06 D$ (see Fig. 1).

11.2.2 Forging defects located in the socket wall within 0.1 times the actual key engagement, T , from the bottom of the socket are not permissible. Discontinuities located elsewhere in the socket shall not have a length exceeding $0.25 T$, or a maximum depth of $0.03 D$ not to exceed 0.005 in. (see Fig. 2).

11.2.3 Seams in the shank shall not exceed a depth of $0.03 D$ or 0.008 in., whichever is greater.

11.2.4 No transverse discontinuities shall be permitted in the head-to-shank fillet area.

11.2.5 Threads shall have no laps at the root or on the flanks located below the pitch line. Laps are permitted at the crests (Fig. 3) that do not exceed 25 % of the basic thread depth, and on the flanks outside the pitch cylinder. Longitudinal seams rolled beneath the root of the thread and across the crests of cut threads are acceptable within the limits of 11.2.3.

12. Number of Tests

12.1 The requirements of this specification shall be met in continuous mass production for stock, and the manufacturer shall make sample inspections to ensure that the product conforms to the specified requirements. Additional tests of individual shipments of fasteners are not ordinarily necessary. A record of the individual heat of steel in each lot shall be maintained. The containers shall be coded to permit identification of the lot.

12.2 When specified in the purchase order, the manufacturer shall furnish a test report of the last complete set of chemical analysis and mechanical tests for each stock size in each shipment.

12.3 When tests of individual shipments are required, Supplementary Requirement S1 must be specified in the inquiry and order.

12.3.1 When the purchaser does not specify the sampling plan and basis of acceptance, the following shall apply:

12.3.1.1 The lot, for purposes of selecting samples, shall consist of all products offered for inspection and testing, at one time, that are the same type, style, nominal diameter, thread pitch, nominal length, material (alloy), condition, and surface finish.

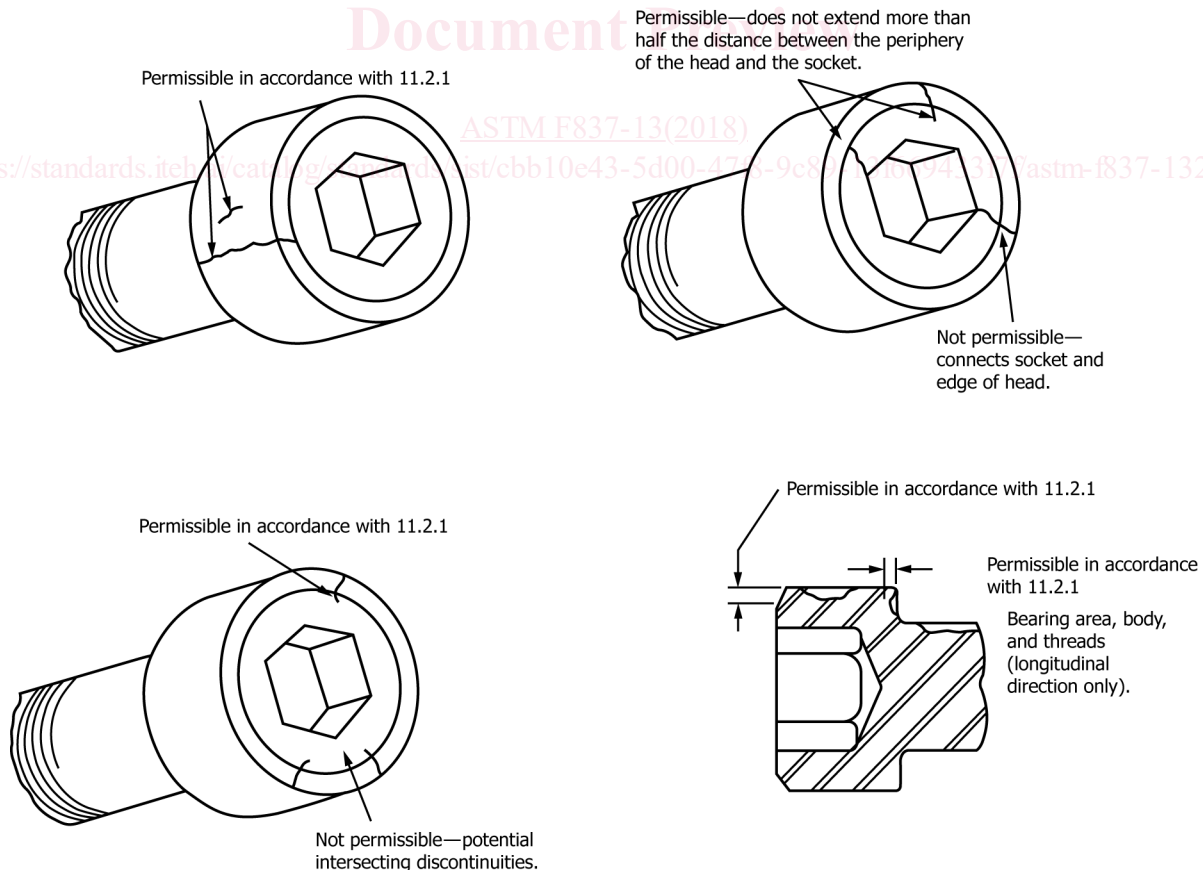

FIG. 1 Head and Body Discontinuity Location and Limits

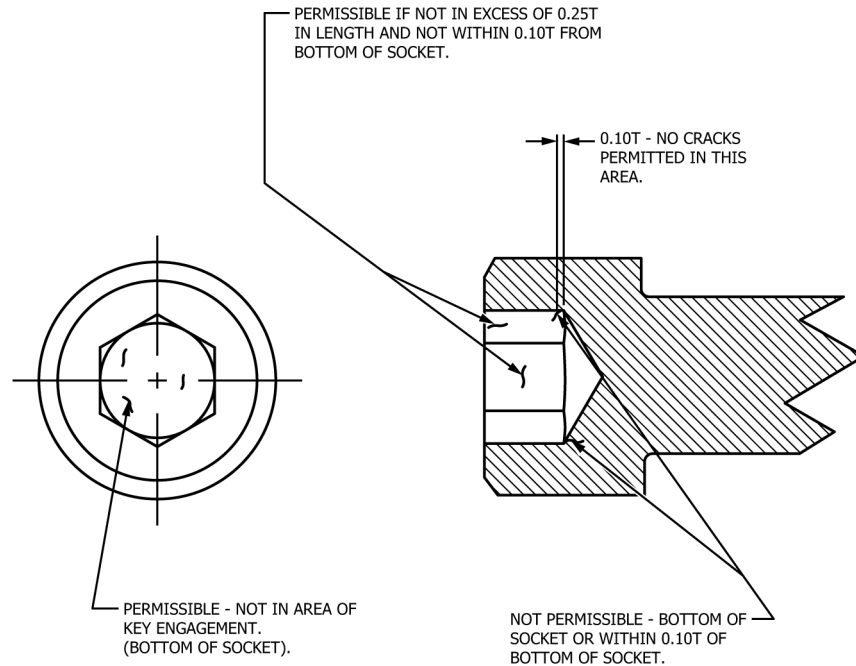

FIG. 2 Socket Discontinuity Location and Limits

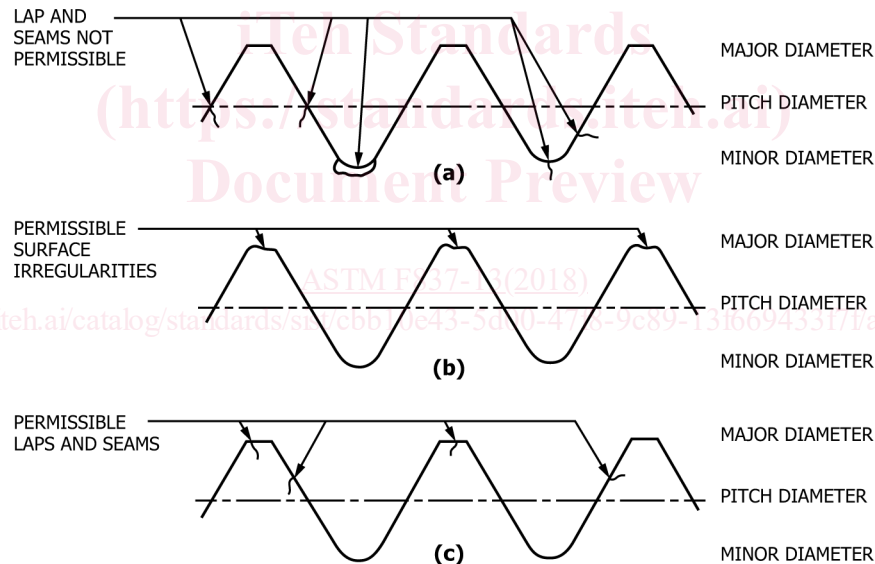

FIG. 3 Thread Discontinuities

12.3.1.2 From each lot, samples shall be selected at random and tested for each requirement in accordance with the following plan:

Number of Pieces in Lot	Number of Samples
800 and less	1
Over 800 to 8000, incl	2
Over 8000 to 22 000, incl	3
Over 22 000	5

12.3.1.3 Should any sample fail to meet the requirements of a specified test, double the number of samples from the same lot shall be retested for the requirement(s) in which it failed. All of the additional samples shall conform to the specification or the lot shall be rejected.

12.3.1.4 If the failure of a test specimen is due to improper preparation of the specimen or an incorrect testing technique, the specimen shall be discarded and another test specimen submitted.