



Designation: F3324 – 18

# Standard Test Method for Measurement of Cut Resistance to Chainsaw in Leg- Protective Devices<sup>1</sup>

This standard is issued under the fixed designation F3324; the number immediately following the designation indicates the year of original adoption or, in the case of revision, the year of last revision. A number in parentheses indicates the year of last reapproval. A superscript epsilon ( $\epsilon$ ) indicates an editorial change since the last revision or reapproval.

## 1. Scope

1.1 This test method measures cut resistance of garments and devices worn to protect the lower body (legs) when operating a chainsaw.<sup>2</sup>

1.2 This test method may be used to test for compliance to minimum performance requirements in established safety standards.

1.3 The values stated in SI units are to be regarded as standard.

NOTE 1—The values stated in each system may not be exact equivalents; therefore, each system must be used independently of the other, without combining values in any way.

1.4 *This standard does not purport to address all of the safety concerns, if any, associated with its use. It is the responsibility of the user of this standard to establish appropriate safety, health, and environmental practices and determine the applicability of regulatory limitations prior to use.*

1.5 *This international standard was developed in accordance with internationally recognized principles on standardization established in the Decision on Principles for the Development of International Standards, Guides and Recommendations issued by the World Trade Organization Technical Barriers to Trade (TBT) Committee.*

## 2. Referenced Documents

### 2.1 ASTM Standards:<sup>3</sup>

[D123 Terminology Relating to Textiles](#)

[D1056 Specification for Flexible Cellular Materials—Sponge or Expanded Rubber](#)

[D1776/D1776M Practice for Conditioning and Testing Textiles](#)

<sup>1</sup> This test method is under the jurisdiction of ASTM Committee F23 on Personal Protective Clothing and Equipment and is the direct responsibility of Subcommittee F23.20 on Physical.

Current edition approved Aug. 15, 2018. Published September 2018. Originally approved in 2018. DOI: 10.1520/F3324-18.

<sup>2</sup> This standard was developed as a replacement for the archived CAN/BNQ 1923-450.

<sup>3</sup> For referenced ASTM standards, visit the ASTM website, www.astm.org, or contact ASTM Customer Service at service@astm.org. For *Annual Book of ASTM Standards* volume information, refer to the standard's Document Summary page on the ASTM website.

[F1494 Terminology Relating to Protective Clothing](#)

[2.2 Military Standard:<sup>4</sup>](#)

[MIL-STD-105 Sampling Procedures and Tables for Inspection by Attributes](#)

[2.3 Federal Standard:<sup>4</sup>](#)

[FS 5100-86 Type II, Cloth, Duck, Nylon, Polyurethane Coated](#)

## 3. Terminology

### 3.1 Definitions:

3.1.1 *chainsaw, n*—a portable, power-operated tool used for cutting wood that has cutters linked in a chain.

3.1.2 *chain speed, n*—the speed of synchronized movement of linked cutters around a guide bar and sprocket.

3.1.3 *chain stop, n*—the resulting action when a material clogs (jams) the drive sprocket or slows the speed sufficiently to prevent advancement of the saw chain.

3.1.4 *cut resistance, n*—in chainsaw testing, the ability of a material, while in contact with the linked cutters, to resist cut-through of the cutters of a moving saw chain independent of either jamming or chain stop.

3.1.5 *cut-through, n*—for chainsaw cut resistance, the action of a running chainsaw after complete breakthrough of either a protective garment or protective device.

3.1.5.1 *Discussion*—When a cut-through is effected, speed of the saw chain must be measured.

3.1.6 *jamming, n*—for chainsaw cut resistance, the clogging action manifested by a protective garment or a device that can produce a chain stop.

3.1.7 *lower body, n*—that part of the human body which includes all portions between the waist and feet, not to include the feet.

3.1.8 *protective clothing, n*—an item of clothing that is specifically designed and constructed for the intended purpose of isolating all or part of the body from a potential hazard, or isolating the external environment from contamination by the clothing.

<sup>4</sup> Available from DLA Document Services, Building 4/D, 700 Robbins Ave., Philadelphia, PA 19111-5094, <http://quicksearch.dla.mil>.

3.1.8.1 *Discussion*—For chainsaw cut-resistant protective clothing, the potential hazard is exposure to a running power saw chain.

3.1.9 *saw chain, n*—a closed loop of cutters linked together for use in a portable, power-operated tool.

3.1.10 *threshold stopping speed, n*—chain speed that results in a ¼-in. cut in the bottom layer of the protective pad liner in a chainsaw leg-protective device.

3.1.10.1 *Discussion*—This value establishes the relationship between the probability of cutting through the protective clothing (or foot-protective device) and the speed of the saw chain. For lower chain speeds, the probability of cut-through approaches zero, while for higher chain speeds, the probability of cut-through approaches one.

3.2 For definitions of other textile terms used in this test method, refer to Terminology **D123**.

3.3 For definitions of other protective clothing terms used in this test method, refer to Terminology **F1494**.

3.4 Pass/fail is a threshold stopping speed value measured in meters per second (feet per minute) of chain travel speed that results in the stated 6-mm (¼-in.) cut in the bottom of the lining of the performance pad of a chainsaw-protective device. (See **3.1.10**.)

#### 4. Summary of Test Method

4.1 Test specimens are securely mounted on a test apparatus that simulates a human leg.

4.2 A chainsaw, of specific characteristic and operating at a designated speed, is brought into contact with the test specimen.

4.2.1 The cutting action of the saw chain will achieve one of the following results: (1) complete cut-through with chain stop, (2) complete cut-through without chain stop, (3) no cut-through with a chain stop, or (4) no cut-through without a chain stop.

4.3 Chain speed is measured electronically just prior to contact with test specimen. Chain speed is adjusted and reported based on these measurements.

NOTE 2—Materials may be characterized by repeated testing at different speeds; for quality control, results may be reported as “pass” or “fail” at one pre-selected chain speed.

#### 5. Significance and Use

5.1 The purpose of this test method is to provide a measurable criterion of performance about the level of cut resistance provided by different types of protective garments and protective coverings worn by chainsaw operators.

5.2 This test method is intended to show to what level a protective garment can offer resistance to the cutting action of a chainsaw.

5.3 The protection that can be demonstrated by the garments and coverings tested in accordance with this test method is achieved by: (1) the cut resistance of the material to cutting when put in contact with saw chain; (2) pulling a part of the material or yarns in the material so that they are drawn into the chain and drive mechanism to block the chain movement; (3)

the fibers of the materials used to demonstrate both high resistance to cutting and the capacity to absorb rotational energy, so that chain speed can be slowed down sufficiently to stop the movement of the saw chain; or (4) any combination of these.

5.4 This test method does not purport to evaluate comfort of lower body protective garments.

5.5 In case of a dispute arising from differences in reported test results when using this test method for acceptance testing of commercial shipments, the purchaser and the supplier should perform comparative tests to determine if there is a statistical bias between their laboratories. Competent statistical assistance is recommended for the investigation of bias. As a minimum, the two parties should take a group of test specimens from the same lot of components to be evaluated. The test specimens should then be randomly assigned in equal numbers to each laboratory for testing. If a bias is found, either its cause must be determined and corrected or the purchaser and the supplier must agree to interpret future test results in light of the known bias.

#### 6. Apparatus<sup>5</sup>

6.1 Apparatus consists of three main components:

6.2 *Specimen Holder:*

6.2.1 A stationary wooden cylinder having a diameter of 150 mm (6 in.) and a minimum length of 350 mm (14 in.) (see **Figs. 1 and 2**).

6.2.1.1 The cylinder is covered with a vinyl nitrile foam having a thickness of 18 mm (0.75 in.) (see **Figs. 1 and 2**). This covering shall have a density between 55 and 80 kg/m<sup>2</sup> and its resistance to a 25 % compression shall be between 10 and 20 kPa, measured in accordance with the testing procedure in Specification **D1056**.

NOTE 3—Ensolite M, a synthetic foam rubber made of PVC and NBR, meets the requirements stipulated in Specification **D1056**.

6.2.1.2 Two specimen attachment plates, each secured by two screws to the wooden cylinder parallel to the axis of that cylinder. Each plate is 75 by 25 mm (3 by 1 in.) (see **Figs. 1 and 2**).

6.2.1.3 The stationary wooden cylinder shall be attached to a swivel mechanism that allows the mandrel to be moved to an angle of either 45° or 90° to the vertical plane of the guide bar. Specimen must be securely attached to mandrel to prevent movement of specimen.

6.3 *Chainsaw and Related Equipment:*<sup>6,7</sup>

6.3.1 *Saw:*

6.3.1.1 A gas-powered chainsaw, having an idle speed of 2250 ± 250 rpm and a maximum power of 3.3 ± 0.3 kW at 8500 rpm that meets the following specifications: (1) minimum

<sup>5</sup> See **Appendix X1** to review maintenance checklist.

<sup>6</sup> Husqvarna Model 570 XP, with an eight-tooth drive sprocket, available from Husqvarna, <http://www.husqvarna.com>.

<sup>7</sup> This is the sole source of supply known to the committee at this time. If you are aware of alternative suppliers, please provide this information to ASTM Headquarters. Your comments will receive careful consideration at a meeting of the responsible technical committee,<sup>1</sup> which you may attend.

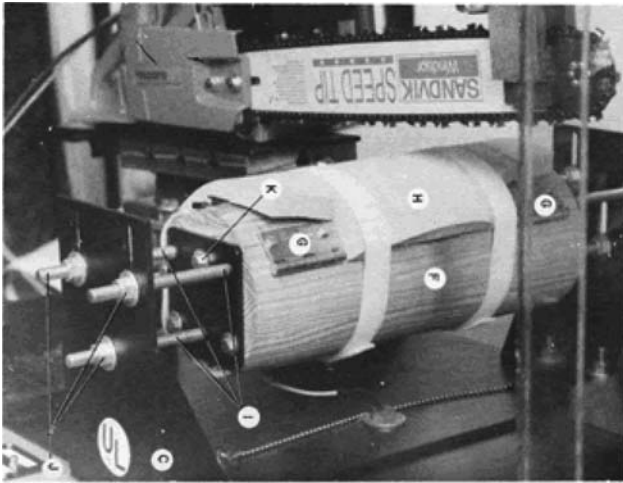

Item	Quantity	Description
A	1	steel plate 0.25 by 576 by 670 mm
B	2	steel plate 0.25 by 216 by 375 mm
C	2	steel plate 0.25 by 208 by 216 mm
D	1	steel tube 0.75 by ID – 1 mm OD by 172 mm
E	1	aluminum plate 0.5 by 4 by 14.5 mm
F	1	hardwood or white pine 152 by 400 mm
G	2	hinge 3 by 3 by 1/16 in.
H	1	foam pad 15 by 180 by 360 mm + glue
I	6	threaded rod 0.40 by 16 by 120 mm
J	12	bolt 0.40 by 16 mm
K	8	wood screw 8 by 0.75 mm TR
L	1	steel axle 0.75 mm diameter x 350 threaded 0.75 mm x 10 mm x 80 mm at each end
M	2	pillow block VPS112 valuline Browning
N	5	bolt 0.75 by 10 mm
O	1	hex bolt 0.75 by 10 by 70 mm
P	1	square 30 mm x 90 mm x 3/16 x 75L
Q	1	stopping block 20 mm x 40 mm x 60L
R	1	lever support 3/16 x 80 mm x 130 mm
S	1	lever 0.25 by 60 by 120 mm
T	1	axle 0.250
U	1	compression spring
V	1	micro-switch
W	1	safety shield pivoting on D

NOTE 1—Measurements are in millimetres. Arcs of a circle are measured on the circumference of the wood cylinder.

FIG. 1 Specimen Holder (Front View Facing Chainsaw)

66.7 cm<sup>3</sup> or 4.0 in.<sup>3</sup>; (2) bore 50 mm; (3) stroke 34 mm; (4) clutch engagement speed of 3450 ± 250 rpm; (5) maximum no-load speed of 12 500 rpm; (6) maximum no-load chain speed of 27 m/s (5475 fpm); and (7) eight-tooth rim drive sprocket. (See Figs. 3 and 4.)

6.3.1.2 Throttle control mechanism is used to maintain constant saw chain speed.

6.3.1.3 The engine of the chainsaw is a two-stroke engine that uses a gasoline/oil mixture. The gasoline shall be premium unleaded without alcohol additive and having a minimum anti-knock rating of 90. The oil shall be a high-quality, two-stroke oil specially developed for chainsaws. Mix ratio is 50 + 1 (2 % two-stroke oil to 98 % gasoline).

6.3.1.4 The chainsaw shall be fitted with a resistive-type plug to reduce interference with the chain speed electronics.

NOTE 4—When testing constraints prevent dynamometer verification, technician is responsible for checking that the engine is running smoothly, starts readily, has a clean screen, if present, a good spark plug, and so forth.

NOTE 5—All requirements of the chainsaw are determined in accordance with many manufacturers' published specifications.

6.3.2 Chain:<sup>8,7</sup>

6.3.2.1 A chain with a pitch of 10 mm (3/8 in.), a 0.058-in. gage, and a round ground full chisel cutter.

6.3.2.2 New chain may be used without sharpening, or the chain must be sharpened using the sharpening procedure noted in Annex A1 before testing.

6.3.3 Guide Bar:

6.3.3.1 A guide bar having a length of 500 mm (20 in.), with an eleven-tooth roller-nose sprocket, designed to accommodate a 10-mm (3/8-in.) pitch, 0.058-in. gage saw chain.

6.3.3.2 The roller nose on the guide bar will need to be cleaned at periodic intervals. To facilitate repeated cleanings, the rivets attaching the roller nose to the bar should be replaced. Modification requires that rivets be removed and

<sup>8</sup> The sole source of supply of the saw chain with a pitch of 10 mm (0.40 in.), 3/8, 72LP (73LP) Oregon Type, known to the committee at this time is Blount, Inc., 4909 S. E. International Way, PO Box 22127, Portland, OR 97222. If you are aware of alternative suppliers, please provide this information to ASTM International Headquarters.

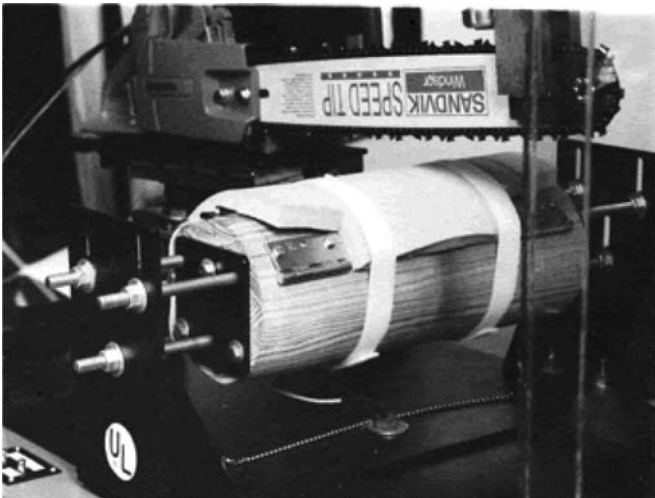

FIG. 2 Specimen Holder (Attachment and Positioning)

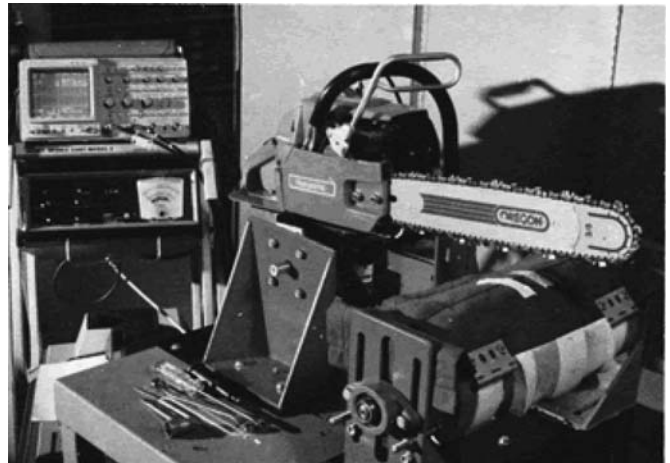

FIG. 3 Post Contact with Specimen (Front View) and Data Acquisition System

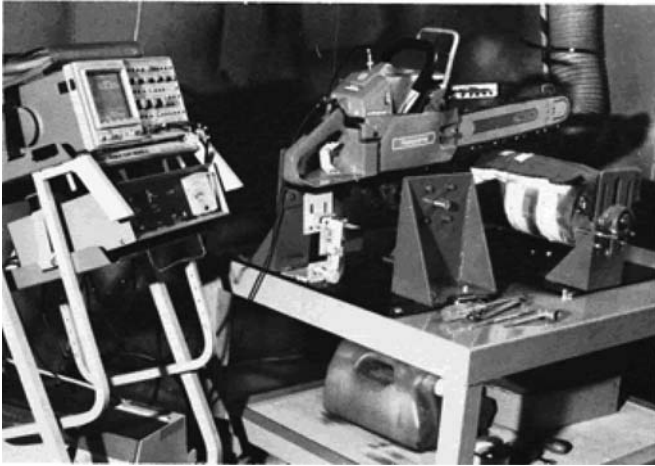

FIG. 4 Post Contact with Specimen (Rear View)

holes be enlarged by drilling, so that aircraft-quality bolts and locking nuts can be used.

6.3.4 *Chain Guidance and Lubrication:*

6.3.4.1 The saw chain shall be able to turn freely around the drive sprocket and roller nose. The system shall be adequately lubricated. Chain tension shall be adjustable so that application of a force of 15 N on the middle of the guide bar causes a chain deflection of  $6 \pm 0.5$  mm.

6.4 *Chainsaw Support Bracket:*

6.4.1 The saw is attached to a metal plate that rotates freely around the axle (see Figs. 5-7).

6.4.2 The horizontal distance between the pivot of the saw and the central axis of the specimen support is  $365 \pm 1$  mm ( $14.2 \pm 0.125$  in.) (see Figs. 5 and 6).

6.4.2.1 The vertical distance between the pivot of the saw and the center of the drive sprocket cannot exceed 130 mm (5 in.).

6.4.3 The mounting mechanism of the chainsaw to the bracket shall be fixed.

6.4.4 The guide bar falls perpendicular to the support axis and exerts a static force of 15 N at the point of contact.

6.4.5 The vertical dropping distance to the point of contact with foam is 50 mm (2 in.). The longitudinal axis of the guide bar is virtually horizontal at the moment of contact (see Figs. 3 and 4).

6.4.6 A trigger release mechanism allows freefall without initial acceleration (see Fig. 4 and Fig. 6).

6.5 *Interfaced Data Acquisition System:*

6.5.1 The cutting time between wires placed on the top and bottom of the specimen is measured to  $\pm 0.001$  s.

6.5.1.1 These wires are connected to the circuitry.

6.5.2 The speed of the saw chain may be measured in metres per second or feet per minute ( $\pm 3$  %) by means of a magnetic pickup which reads data from a pickup band that is pressed onto the clutch housing. This data is then read by a tachometer which is calibrated to read this information. Some other effective means may be used to determine chain speed with equivalent precision (see Fig. 3).

7. Hazards

7.1 **Warning**—The chainsaw equipment used in this test method can pose a potential danger to the technician if specific safety cautions are not followed.

7.2 As a minimum safety precaution, it is suggested that the spark plug wire be disengaged until the engine needs to be started.

7.3 As a further safety precaution, it is suggested that the spark plug wire be grounded by circuitry after cutting the lower wire of the data collection system. If the chain stops before this wire is cut, or if the chain slides over the specimen, a timer should limit the test and stop the engine by grounding the electric circuitry of the chainsaw.

7.4 The technician performing this test method should use ear protection to avoid potential hearing injury.

7.5 The technician performing this test method should use eye protection to avoid potential eye injury.

7.6 The chainsaw motor should be vented to prevent potential danger posed by carbon monoxide gas.

8. Sampling

8.1 *Lot Sample*—As a lot sample for acceptance testing, take at random the number of shipping containers directed in an applicable material specification or other agreement between the purchaser and the supplier. Consider shipping containers to be the primary sampling units.

NOTE 6—An adequate specification or other agreement between the purchaser and the supplier requires taking into account the variability between shipping containers, between laboratory samples within a shipping container, and between test specimens within a laboratory sample to provide a sampling plan with a meaningful producer's risk, consumer's risk, acceptable quality level, and limiting quality level.

8.2 *Specimen Preparation:*

8.2.1 The specimen shall be of the same fabric assembly as that used in the protective garment. Its technical description (number of layers, fabric used, etc.) shall be supplied.

8.2.2 Four holes, 6 mm (0.25 in.) in diameter, shall be punched into the specimen in the laboratory at the places specified. Use these holes to position and to fasten the specimen to the test apparatus. Construct a template for consistency among specimens (Fig. 8).

8.3 *Number of Specimens:*

8.3.1 Use each specimen only once. Each leg of a paired item can be considered a specimen.

8.3.2 Use at least three unconditioned specimens to determine threshold stopping speed of calibration pads.

8.3.3 Use at least three unconditioned specimens and three conditioned specimens if this test method is used to determine the threshold stopping speed of performance pads.

9. Calibration

9.1 Calibration pads shall be composed of the following:

- (1) Top cover layer—no less than 400 denier nylon fabric.
- (2) Inner pad layers shall be constructed in the following manner:

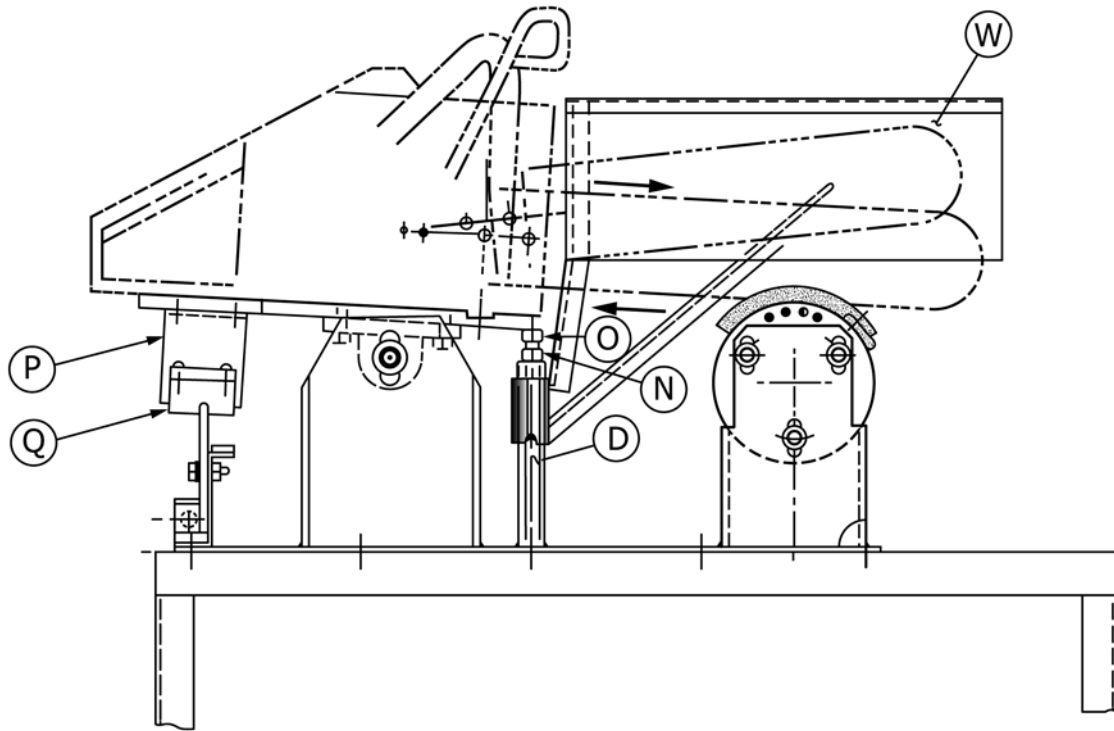

Item	Quantity	Description
A	1	steel plate 0.25 by 576 by 670 mm
B	2	steel plate 0.25 by 216 by 375 mm
C	2	steel plate 0.25 by 208 by 216 mm
D	1	steel tube 0.75 by ID - 1 mm OD by 172 mm
E	1	aluminum plate 0.5 by 4 by 14.5 mm
F	1	hardwood or white pine 152 by 400 mm
G	2	hinge 3 by 3 by 1/16 in.
H	1	foam pad 15 by 180 by 360 mm + glue
I	6	threaded rod 0.40 by 16 by 120 mm
J	12	bolt 0.40 by 16 mm
K	8	wood screw 8 by 0.75 mm TR
L	1	steel axle 0.75 mm diameter x 350 threaded 0.75 mm x 10 mm x 80 mm at each end
M	2	pillow block VPS112 valuline browng
N	5	bolt 0.75 by 10 mm
O	1	hex bolt 0.75 by 10 by 70 mm
P	1	square 30 mm x 90 mm x 3/16 x 75L
Q	1	stopping block 20 mm x 40 mm x 60L
R	1	lever support 3/16 x 80 mm x 130 mm
S	1	lever 0.25 by 60 by 120 mm
T	1	axle 0.250
U	1	compression spring
V	1	micro-switch
W	1	safety shield pivoting on D

NOTE 1—Measurements are in millimetres. Arcs of a circle are measured on the circumference of the wood cylinder.

FIG. 5 Chainsaw Support Bracket (Side View)

(a) One layer of Lincoln Fabrics woven Kevlar #49 style #30316.0580.2000 plain weave;

(b) Thirteen (13) ends twelve picks griegie fabric only; followed by

(c) One layer of Albarrie Canada Ltd. felt style 5101; followed by

(d) One layer of Lincoln Fabrics woven Kevlar #49; followed by

(e) One layer of Albarrie Canada Ltd. felt style 5101.

(3) Bottom cover layer—no less than 70 denier Tricot fabric.

9.1.1 Pads will measure a minimum of 200 by 700 mm (8 by 28 in.).

9.1.2 Stitch the inner pad material to the outer cover 25 mm (1 in.) from the edge on all four sides.

9.2 Determine the accuracy of the test apparatus, before and after each test lot, by verifying that the threshold stopping speed calibration specimen is 15 m/s (3000 fpm) at 90°.

9.2.1 If threshold stopping speed deviates more than ±1.0 m/s (200 fpm), the saw chain must be re-sharpened to meet the specifications in accordance with 6.3.2.

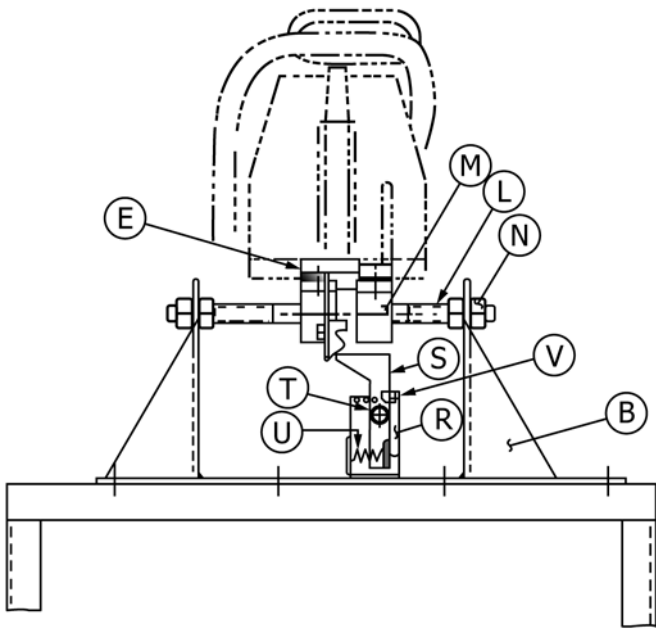

Item	Quantity	Description
A	1	steel plate 0.25 by 576 by 670 mm
B	2	steel plate 0.25 by 216 by 375 mm
C	2	steel plate 0.25 by 208 by 216 mm
D	1	steel tube 0.75 by ID – 1 mm OD by 172 mm
E	1	aluminum plate 0.5 by 4 by 14.5 mm
F	1	hardwood or white pine 152 by 400 mm
G	2	hinge 3 by 3 by 1/16 in.
H	1	foam pad 15 by 180 by 360 mm + glue
I	6	threaded rod 0.40 by 16 by 120 mm
J	12	bolt 0.40 by 16 mm
K	8	wood screw 8 by 0.75 mm TR
L	1	steel axle 0.75 mm diameter x 350 threaded 0.75 mm x 10 mm x 80 mm at each end
M	2	pillow block VPS112 valuline browng
N	5	bolt 0.75 by 10 mm
O	1	hex bolt 0.75 by 10 by 70 mm
P	1	square 30 mm x 90 mm x 3/16 x 75L
Q	1	stopping block 20 mm x 40 mm x 60L
R	1	lever support 3/16 x 80 mm x 130 mm
S	1	lever 0.25 by 60 by 120 mm
T	1	axle 0.250
U	1	compression spring
V	1	micro-switch
W	1	safety shield pivoting on D

NOTE 1—Measurements are in millimetres. Arcs of a circle are measured on the circumference of the wood cylinder.

FIG. 6 Chainsaw Support Bracket (Rear View from Motor)

## 10. Conditioning

10.1 The test specimen shall be subjected to three complete laundering cycles in accordance with the following instructions:

10.1.1 A front-loading washer/extractor shall be used.

10.1.2 The wash load shall be one-half the rated capacity of the washer. If ballast is needed to reach one-half capacity, 100 % cotton material shall be used.

10.1.3 No detergent shall be used.

10.1.4 The wash cycle procedure and water levels specified in Table 1 shall be followed.

10.1.5 Samples shall be dried using a tumble dryer with a stack temperature of  $45 \pm 5 \text{ }^\circ\text{C}$  ( $113 \pm 9 \text{ }^\circ\text{F}$ ) when measured on an empty load no less than 20 min into the drying cycle.

10.1.6 Samples shall be tumbled for no less than 30 min, and shall be removed immediately at the end of the drying cycle.

10.1.7 The test specimens shall then be brought from the dry side to approximate moisture equilibrium in accordance with Practice D1776/D1776M.

NOTE 7—Equilibrium is considered to have been reached when the increase in mass of the specimen in successive weighings, made at intervals of not less than 2 h, does not exceed 0.1 % of the mass of the specimen.

## 11. Procedure

### 11.1 Placement of Specimen:

11.1.1 Position the bottom timing wire from the interfaced data acquisition system beneath the specimen to be tested.

11.1.1.1 This wire should be taut against the foam pad at a constant force, directly on the foam pad at the point of contact with the saw chain and perpendicular to the axis of the guide bar.

11.1.2 Carefully position the specimen and securely mount to the holder so that the holes can be aligned for the attachment. The position of these holes is shown in Fig. 8.

11.1.2.1 Lock the specimen holder into place at the appropriate angle of either  $45^\circ$  or  $90^\circ$ .

11.1.2.2 Reposition any hooks, buckles, closures, or other devices that make up part of the protective garment or covering so as not to inhibit the specimen from being placed flat against the cylinder. When unable to reposition the hooks, buckles, closures, or other devices, remove them either in part or completely.

NOTE 8—If it has been shown that the performance pads under test either jam the saw or are cut through in less than 0.2 s, then the timing wires may be omitted and pass/fail will be based only on cut-through.

NOTE 9—Each leg of a paired item can be considered a specimen.

11.2 Use each specimen for only one test.

11.3 Put the upper timer wire through the two center holes of the specimen. Attach each end of wire to a terminal of the interfaced circuitry.

11.3.1 Place this wire taut against the specimen without exerting any tension stress.

11.3.2 Verify the continuity of all circuits prior to starting chainsaw procedures.

### 11.4 Chainsaw:

11.4.1 Clean and visually check the chainsaw after every test cutting. Correct any abnormality.

11.4.2 Refuel and oil after every ten test cuts.

NOTE 10—Refueling avoids significant variations in mass.

11.4.3 Start the chainsaw and warm up for approximately 2 min. Adjust the chainsaw to the specific speed for the trial in progress.

11.4.4 Before the test, turn on the recording circuitry so that a record can be made of the chain speed and cut-through.