



Designation: **D1708—13 D1708—18**

Standard Test Method for Tensile Properties of Plastics by Use of Microtensile Specimens¹

This standard is issued under the fixed designation D1708; the number immediately following the designation indicates the year of original adoption or, in the case of revision, the year of last revision. A number in parentheses indicates the year of last reapproval. A superscript epsilon (ϵ) indicates an editorial change since the last revision or reapproval.

This standard has been approved for use by agencies of the U.S. Department of Defense.

1. Scope*

1.1 This test method covers certain material specifications for which a history of data has been obtained using the standard microtensile specimen. In general, this test method is superseded for general use by either Test Method **D882** or Test Method **D638**. The very small Type V specimen in Test Method **D638** is the recommended specimen when limited amounts of material are available.

1.2 This test method covers the determination of the comparative tensile strength and elongation properties of plastics in the form of standard microtensile test specimens when tested under defined conditions of pretreatment, temperature, humidity, and testing machine speed. This method is applicable when using specimens of any thickness up to 3.2 mm ($\frac{1}{8}$ in.), including thin films.

1.3 This test method cannot be used for the determination of modulus of elasticity. For the determination of modulus, see Test Method **D638** or Test Methods **D882**.

1.4 ~~Test data~~ Data obtained by this test method are relevant and appropriate for use in engineering design.

NOTE 1—Tensile properties provide useful data for plastics engineering design purposes. However, because of the high degree of sensitivity exhibited by many plastics to rate of straining and environmental conditions, data obtained by this test method cannot be considered valid for applications involving load-time scales or environments widely different from those of this test method. In cases of such dissimilarity, no reliable estimation of the limit of usefulness can be made for most plastics. This sensitivity to rate of straining and environment necessitates testing over a broad load-time scale (including impact and creep) and range of environmental conditions if tensile properties are to suffice for engineering design purposes.

1.5 The values stated in SI units are to be regarded as standard. The values given in parentheses are for information only.

1.6 *This standard does not purport to address all of the safety concerns, if any, associated with its use. It is the responsibility of the user of this standard to establish appropriate ~~safety~~ safety, health, and health environmental practices and determine the applicability of regulatory limitations prior to use.*

NOTE 2—There is no known ISO equivalent to this standard.

1.7 This international standard was developed in accordance with internationally recognized principles on standardization established in the Decision on Principles for the Development of International Standards, Guides and Recommendations issued by the World Trade Organization Technical Barriers to Trade (TBT) Committee.

2. Referenced Documents

2.1 *ASTM Standards:*²

- [D618 Practice for Conditioning Plastics for Testing](#)
- [D638 Test Method for Tensile Properties of Plastics](#)
- [D882 Test Method for Tensile Properties of Thin Plastic Sheeting](#)
- [D883 Terminology Relating to Plastics](#)
- [D4000 Classification System for Specifying Plastic Materials](#)
- [D5947 Test Methods for Physical Dimensions of Solid Plastics Specimens](#)

¹ This test method is under the jurisdiction of ASTM Committee **D20** on Plastics and is the direct responsibility of Subcommittee **D20.10** on Mechanical Properties. Current edition approved ~~Sept. 1, 2013~~ Oct. 1, 2018. Published ~~September 2013~~ October 2018. Originally approved in 1959. Last previous edition approved in 2010 ~~2013~~ as ~~D1708—10~~ **D1708—13**. DOI: ~~10.1520/D1708-13~~ [10.1520/D1708-18](#).

² For referenced ASTM standards, visit the ASTM website, www.astm.org, or contact ASTM Customer Service at service@astm.org. For *Annual Book of ASTM Standards* volume information, refer to the standard's Document Summary page on the ASTM website.

*A Summary of Changes section appears at the end of this standard

- [D6988 Guide for Determination of Thickness of Plastic Film Test Specimens](#)
- [E691 Practice for Conducting an Interlaboratory Study to Determine the Precision of a Test Method](#)
- [E2935 Practice for Conducting Equivalence Testing in Laboratory Applications](#)

3. Terminology

3.1 *Definitions*—Definitions of terms applying to this test method appear in Terminology [D883](#) and Test Method [D638](#), Annex A2.

4. Significance and Use

4.1 This test method provides data for quality control and acceptance or rejection under specifications.

4.2 Before proceeding with this test method, reference ~~should be made to the~~ ASTM specification of the material being tested. Any test specimen preparation, conditioning, dimensions, or testing parameters, or combination thereof, covered in the materials specification ~~shall take~~ takes precedence over those mentioned in this test method. If there are no material specifications, then the default conditions herein apply. ~~Table 1~~ Table 1 of Classification System [D4000](#) lists the ASTM materials standards that currently exist.

5. Apparatus

5.1 The apparatus shall be as specified in Test Method [D638](#), with the following exceptions:

5.1.1 *Grips*—Use serrated grips faces with care, since yielding or tearing at the grips may interfere with measurement of elongation even when the specimen breaks in the reduced section. Grips with rubber coated faces are recommended for thin specimens. Self-tightening grips that move as they tighten and result in a change in the grip separation between upper and lower grips are not satisfactory for this test method. If the specimen tab is not long enough to prevent the grip faces from cocking, use shims to provide more uniform clamping.

5.1.2 *Drive Mechanism*—~~The~~ Regulate the velocity of the drive mechanism ~~shall be regulated~~ as specified in Section 8.

5.1.3 ~~The~~ Construct the fixed and movable members, drive mechanism, and grips ~~shall be constructed~~ of such materials and in such proportions that, after grip slack is taken up, the total elastic longitudinal deformation of the system constituted by these parts does not exceed 1 % of the total longitudinal deformation between the grips at any time during the test. If this is not possible, appropriate corrections shall be made in the calculation of strain values.

5.1.4 *Extension Indicator*—~~The~~ Use an extension indicator ~~shall be~~ capable of determining the distance between grips at any time during the test. ~~The instrument shall be test,~~ essentially free of inertia lag at the specified speed of testing, and ~~shall be~~ accurate to ±1 % of extension or better.

NOTE 3—It is desirable that the load indicator and the extension indicator be combined into one instrument, which automatically records the load as a function of the extension or as a function of time. In the latter case, the conversion to a load-extension record can readily be made because extension is proportional to time after the take-up of the initial grip slack.

5.1.5 *Micrometers*—~~Apparatus~~ Use apparatus for measuring the width and thickness of the test specimen ~~shall comply that~~ complies with the requirements of Test Method [D5947](#) and shall read to 0.0025 mm (0.0001 in.) or less. Measure film thickness in accordance with Guide [D6988](#).

6. Test Specimens

6.1 ~~Microtensile~~ Use microtensile test specimens ~~shall that~~ conform to the dimensions shown in [Fig. 1](#). ~~This specimen shall be prepared~~ Prepare specimens by injection molding, compression molding, die-cutting or machining from sheet, plate, slab, or finished article. Dimensions of a die suitable for preparing die-cut specimens are also shown in [Fig. 1](#). ~~Specimens may also be prepared by injection molding or compression molding.~~

TABLE 1 Tensile StrengthStress at Break for Seven Laboratories and Two Materials, MPa

Material	Test Speed, mm/min	Average	S_r^A	S_R^B	r^C	R^D
Polyamide(imide)	1.3	193.6	1.60	5.48	4.48	15.3
Polybutylene	12.7	31.3	0.80	2.75	9.12	9.12

^A S_r is the within-laboratory standard deviation for the indicated material. It is obtained by pooling the within-laboratory standard deviations of the test results from all of the participating laboratories:

$$S_r = [((S_1)^2 + (S_2)^2 + \dots + (S_n)^2)/n]^{1/2} \tag{1}$$

^B S_R is the between-laboratories reproducibility, expressed as a standard deviation, for the indicated material.

^C r is the within-laboratory repeatability limit, $r = 2.8 \times S_r$.

^D R is the between-laboratory reproducibility limit, $R = 2.8 \times S_R$.

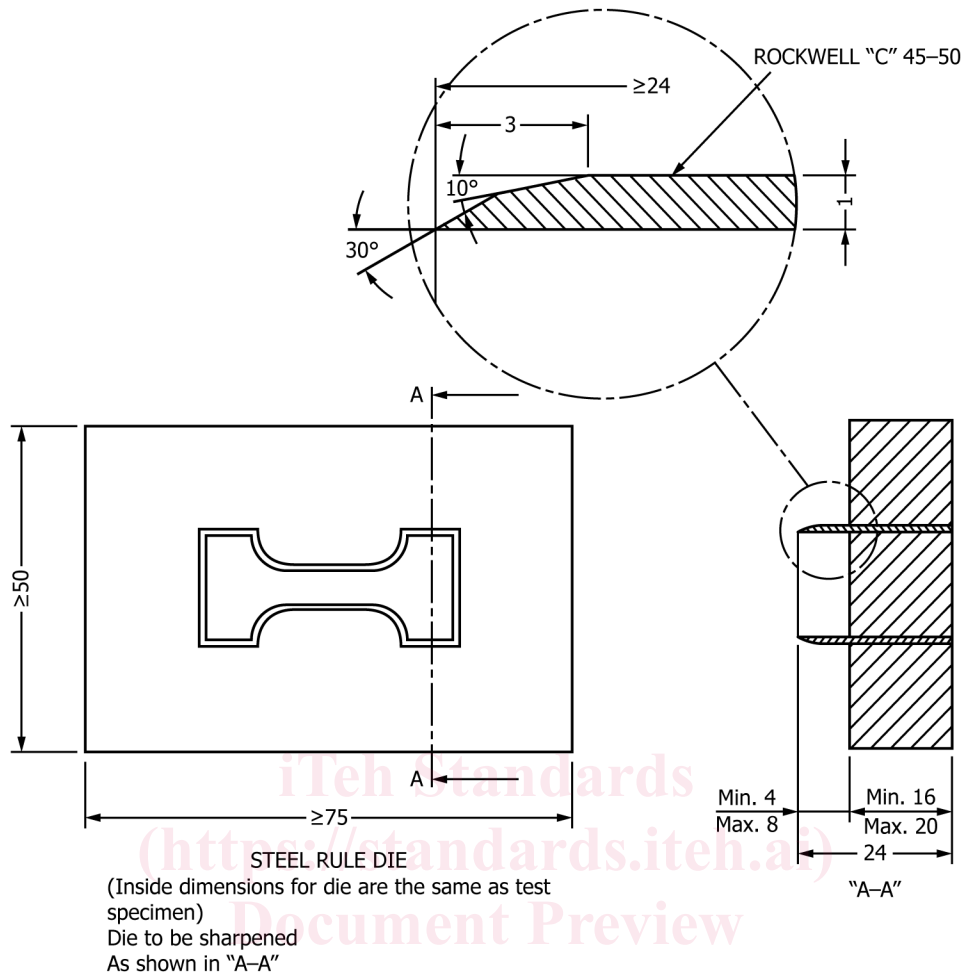

STEEL RULE DIE
 (Inside dimensions for die are the same as test specimen)
 Die to be sharpened
 As shown in "A-A"

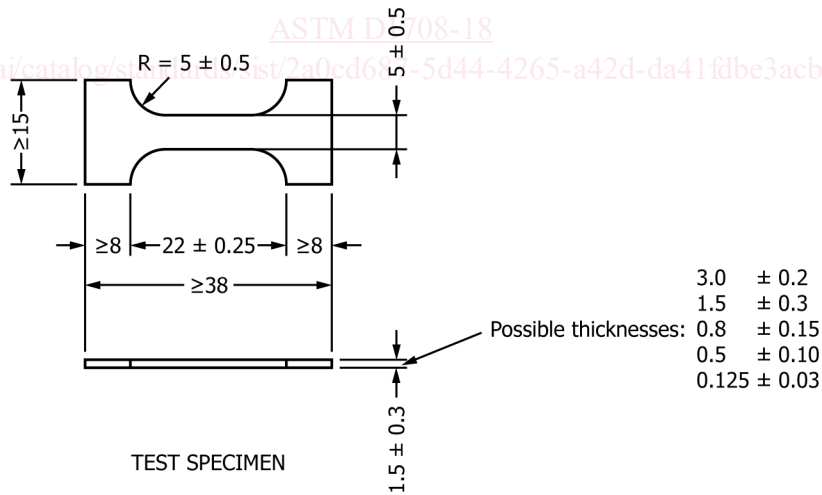

TEST SPECIMEN

NOTE 1—All dimensions are in millimetres.
FIG. 1 Microtensile Die and Test Specimen

6.2 All surfaces of the specimen shall be free of visible flaws, scratches, or imperfections. ~~Carefully remove marks left by coarse machining operations shall be carefully removed with a fine file or abrasive, and abrasive. Smooth the filed surfaces shall then be smoothed with abrasive paper (No. 00 or finer). The Make the finishing sanding strokes shall be made in the direction parallel to the long axis of the test specimen.~~

NOTE 4—Tabs shown in Fig. 1 are minimum size for adequate gripping. Shims may be required with thicker specimens to keep grips from cocking. Handling is facilitated and gripping improved by the use of larger tabs wherever possible.