



Designation: D4061 – 13 (Reapproved 2018)

Standard Test Method for Retroreflectance of Horizontal Coatings¹

This standard is issued under the fixed designation D4061; the number immediately following the designation indicates the year of original adoption or, in the case of revision, the year of last revision. A number in parentheses indicates the year of last reapproval. A superscript epsilon (ϵ) indicates an editorial change since the last revision or reapproval.

1. Scope

1.1 This test method describes the instrumental measurement of the retroreflective properties of horizontal surfacing materials, such as traffic stripe paint systems, traffic tapes, and traffic surface symbols.

1.2 Specimen preparation, size, and shape must be determined and specified by the user of this test method. Likewise, the user must specify the observation and entrance angles to be used (see Fig. 1).

1.3 The geometric requirements of this test method are based on materials for which the relative retroreflectance changes less than approximately 50 % over the observation angle range from 0.2 to 0.5°. This is illustrated in Fig. 2.

1.4 This test method is a laboratory test and requires a facility that can be darkened sufficiently so that stray light does not affect the test results. This facility must be capable of housing the required 15-m test distance.

1.5 The values stated in SI units are to be regarded as standard. No other units of measurement are included in this standard.

1.6 *This standard does not purport to address all of the safety concerns, if any, associated with its use. It is the responsibility of the user of this standard to establish appropriate safety, health, and environmental practices and determine the applicability of regulatory limitations prior to use.*

1.7 *This international standard was developed in accordance with internationally recognized principles on standardization established in the Decision on Principles for the Development of International Standards, Guides and Recommendations issued by the World Trade Organization Technical Barriers to Trade (TBT) Committee.*

¹ This test method is under the jurisdiction of ASTM Committee E12 on Color and Appearance and is the direct responsibility of Subcommittee E12.10 on Retroreflection.

Current edition approved Oct. 1, 2018. Published October 2018. Originally approved in 1989. Last previous edition approved in 2013 as D4061 – 13. DOI: 10.1520/D4061-13R18.

2. Referenced Documents

2.1 *ASTM Standards:*²

E284 Terminology of Appearance

E308 Practice for Computing the Colors of Objects by Using the CIE System

E691 Practice for Conducting an Interlaboratory Study to Determine the Precision of a Test Method

E808 Practice for Describing Retroreflection

E809 Practice for Measuring Photometric Characteristics of Retroreflectors

2.2 *CIE Publication:*³

No. 54 Retroreflection Definition and Measurement

3. Terminology

3.1 The terms and definitions in Terminology E284 apply to this test method.

3.2 *Definitions:*

3.2.1 *coefficient of retroreflected luminance, R_L , n* —ratio of the luminance, L , of a projected surface to the normal illuminance, E_{\perp} , at the surface on a plane normal to the incident light, expressed in candelas per square metre per lux ($\text{cd}\cdot\text{m}^{-2}\cdot\text{lx}^{-1}$).

$$R_L = (L/E_{\perp}) \quad (1)$$

3.2.2 *datum mark, n* —*in retroreflection*, an indication on the retroreflector that is used to define the orientation of the retroreflector with respect to rotation about the retroreflector axis.

3.2.2.1 *Discussion*—The datum mark must not lie on the retroreflector axis.

3.2.3 *entrance angle, β , n* —*in retroreflection*, angle between the illumination axis and the retroreflector axis.

3.2.3.1 *Discussion*—For plane retroreflective surfaces, the entrance angle is no larger than 90°.

² For referenced ASTM standards, visit the ASTM website, www.astm.org, or contact ASTM Customer Service at service@astm.org. For *Annual Book of ASTM Standards* volume information, refer to the standard's Document Summary page on the ASTM website.

³ Available from U.S. National Committee of the CIE (International Commission on Illumination), C/o Thomas M. Lemons, TLA-Lighting Consultants, Inc., 7 Pond St., Salem, MA 01970, http://www.cie-usnc.org.

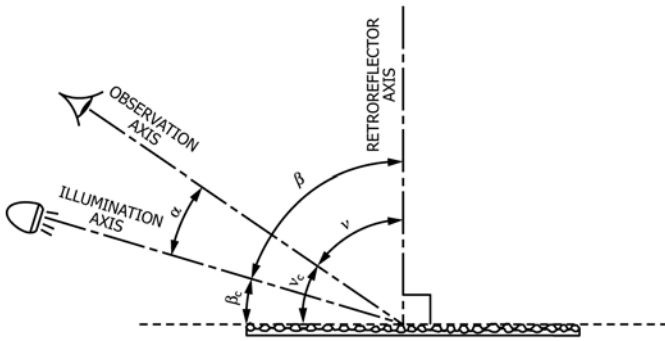

NOTE 1—Includes observation angle α , entrance angle β , viewing angle v_a , co-viewing angle v_c , and co-entrance angle β_c . The retroreflector axis, illumination axis, and observation axis all lie in the same plane.

FIG. 1 Diagram Illustrating Geometry for Measurement of Horizontal Coatings Specimens

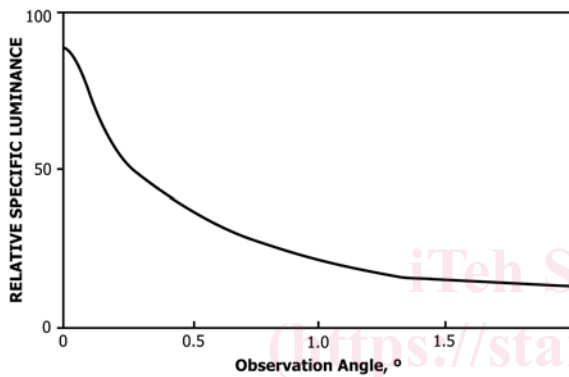

FIG. 2 Illustration of Typical Rate of Change of Retroreflectance Versus Observation Angle for Horizontal Retroreflective Material Measured at 86° Entrance Angle

3.2.3.2 Discussion—The entrance angle may be divided into components β_1 and β_2 . This is described in Practice E808. In this test method only the component β_1 is used. Therefore, where only the entrance angle β is specified the convention used is $\beta_2 = 0$ and $\beta_1 = \beta$.

3.2.4 illumination axis, *n*—in retroreflection, a line from the effective center of the source aperture to the retroreflector center.

3.2.5 normal illuminance, E_{\perp} —the illuminance on a retroreflective surface measured in the plane that passes through the retroreflector center and is perpendicular to the illumination axis; measured in lux ($\text{lumens}\cdot\text{m}^{-2}$).

3.2.6 observation angle, *n*—angle between the axes of the incident beam and the observed (reflected) beam, (in retroreflection, α , between the illumination axis and the observation axis).

3.2.6.1 Discussion—The observation angle is always positive and in the context of retroreflection is restricted to small acute angles.

3.2.7 observation axis, *n*—in retroreflection, a line from the effective center of the receiver aperture to the retroreflector center.

3.2.8 receiver, *n*—the portion of a photometric instrument that receives the viewing beam from the specimen, including a

collector such as an integrating sphere, if used, often the monochromator or spectral filters, the detector, and associated optics and electronics.

3.2.9 retroreflection, *n*—reflection in which the reflected rays are preferentially returned in directions close to the opposite of the direction of the incident rays, this property being maintained over wide variations of the direction of the incident rays. [CIE]^B

3.2.10 retroreflector axis, *n*—a designated line segment from the retroreflector center that is used to describe the angular position of the retroreflector.

3.2.10.1 Discussion—The direction of the retroreflector axis is usually chosen centrally among the intended directions of illumination; for example, the direction of the road on which or with respect to which the retroreflector is intended to be positioned. In testing horizontal road markings the retroreflector axis is usually the normal to the test surface.

3.2.11 rotation angle, ϵ , *n*—angle indicating the orientation of the specimen when it is rotated about a selected axis fixed in it (for plane specimens, usually the specimen normal); in retroreflection, the dihedral angle from the half-plane originating on the retroreflector axis and containing the positive part of the second axis to the half-plane originating on the retroreflector axis and containing the datum mark.

3.2.11.1 Discussion—The rotation angle shown in Fig. 3, with the datum mark oriented away from the source, is 0°.

3.2.12 source, *n*—an object that produces light or other radiant flux.

3.2.13 specific luminance—see coefficient of retroreflected luminance.

3.2.14 viewing angle, *v*—the angle between the observation axis and the retroreflector axis.

3.2.14.1 Discussion—In testing road markings specimens, the retroreflector axis is usually the normal to the test surface (see definition of retroreflector axis).

3.3 Definitions of Terms Specific to This Standard:

3.3.1 co-entrance angle, β_c , *n*—the complement of the entrance angle ($90^\circ - \beta$).

3.3.1.1 Discussion—On a typical test specimen, this is the angle from the plane surface of the material to the observation axis.

3.3.2 co-viewing angle, v_c , *n*—the complement of the viewing angle ($90^\circ - \eta$).

4. Summary of Test Method

4.1 This test method involves the use of a light-projector source, a photoreceptor, a specimen holder, and a receptor-source support, all arranged with approximately 15-m separation between the specimen holder and receptor-source support in a suitable darkened area. The observation angle is generally small (0.2 to 2.0°) and the entrance angle approaches 90° (the light is near the grazing angle).

4.2 The general procedure is to determine the ratio of the retroreflected light from the test surface to the incident light on the test surface. From these measurements, the photometric quantity, specific luminance is calculated.

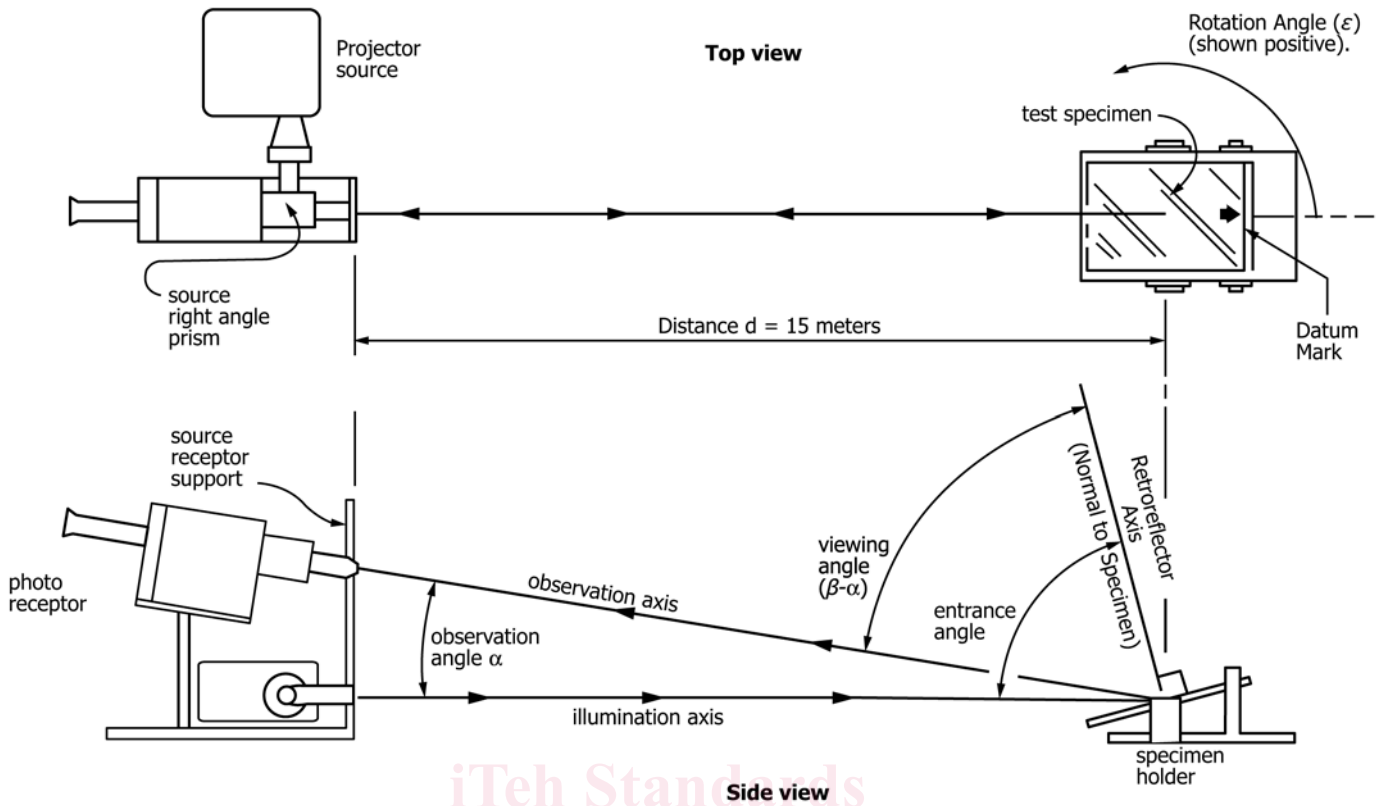

FIG. 3 Arrangement of Test Apparatus

5. Significance and Use

5.1 The quantity coefficient of retroreflected luminance is a measure of the reflected luminance in the direction of the observer. This is the light returned by the retroreflective surface to the observer from the source, which in practice is the vehicle headlamp.

5.2 This test method may be used as a measure of the nighttime performance of horizontally applied surfacing materials used on highway surfaces for lane markings and other traffic control purposes.

5.3 Since this test method is a laboratory procedure, test specimens must be prepared so that they can be mounted on the specimen holder. Specimens measured by this laboratory method may be used as transfer standards for the calibration of portable instrumentation.

5.4 Specimen selection and preparation may significantly influence the results of this test method.

6. Apparatus

6.1 *Light Source*, projector type, meeting the following requirements:⁴

6.1.1 *Color Temperature*—The projection lamp together with the projection optics shall be operated so that they illuminate the test specimen with the spectral energy distribu-

⁴ A commercial slide projector with 7-in. F-3.5 lens and with the heat absorbing filter removed has been found satisfactory as a light source. Such a projector must be run at reduced voltage to achieve the required color temperature and to provide adequate lamp stability.

tion of the 1931 CIE Standard Source A⁵ (a correlated color temperature of 2856 K). A method for determining correlated color temperature is contained in Annex A3 of Practice E809.

6.1.2 *Exit Aperture*—The source exit aperture shall be 43 mm maximum diameter. This corresponds to 10 min of arc angular aperture at 15 m test distance. In practice, it is convenient to provide the projection with a non-silvered right angle prism so that the external physical size of the exit aperture is small, allowing its close proximity to the entrance aperture of the photoreceptor.

6.1.3 *Illuminated Area*—The illumination at the specimen produced by the projector shall be such that only the test surface and a minimum of the background is illuminated. This is commonly accomplished by placing a restrictive aperture in the projector slide port.⁶

6.1.4 *Source Stability*—The source shall be regulated such that the illumination at the test surface does not change by more than $\pm 1\%$ for the duration of the test.

6.1.5 *Illumination Uniformity*—The illumination produced on the specimen surface shall be uniform within $\pm 5\%$ of the average illuminance normal to the source at the test distance.

6.2 *Photoreceptor*,⁷ meeting the following requirements:

6.2.1 *Sensitivity*—The photoreceptor shall have sufficient sensitivity and range so that readings of both the incident illuminance and the retroreflected light at the observation

⁵ See Practice E308, Table 3.

⁶ A slide with a 3- by 15-mm opening has been found satisfactory.

⁷ Commercially available instruments commonly referred to as telephotometers have been found satisfactory for this purpose.

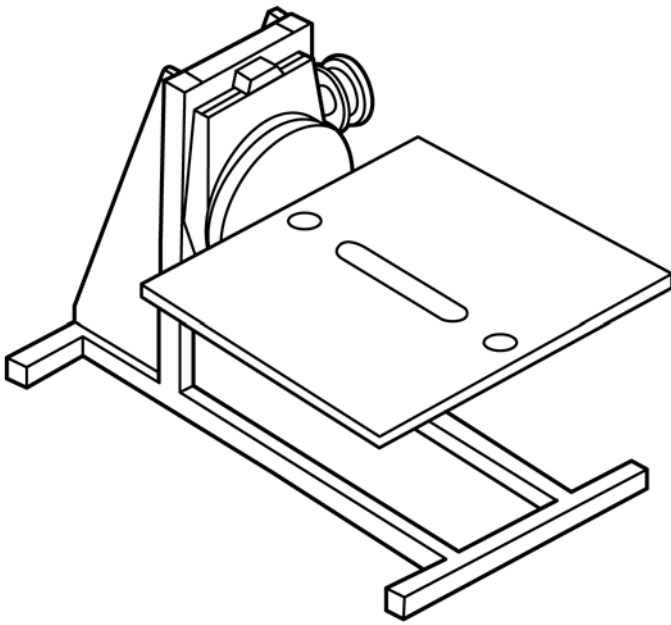

FIG. 4 Example of Specimen Holder Using Machinist's Rotary Table

position can be measured with a resolution of at least 1 part in 50 on the readout scale.

6.2.2 *Spectral Response*—The spectral response of the photoreceptor shall match that of the 1931 CIE Standard Photopic Observer.⁸ See Annex A1 of Practice E809.

6.2.3 *Stability*—The receptor response shall not vary more than $\pm 1\%$ for the duration of the test.

6.2.4 *Linearity*—The linearity of the photometric scale over the range of readings to be taken shall be within $\pm 1\%$. Correction factors may be used to ensure linear response. A method for determining linearity is contained in Practice E809, Annex A2.

6.2.5 *Field of View*—The field of view shall be limited by use of light baffles or a field aperture on the instrument so that the entire test specimen is fully within the field of view yet as much stray light is rejected as is practical. A background light level less than 5 % of smallest m_1 reading (see 8.6) is desirable. When background levels are greater than 5 %, careful attention must be given to noise levels.

6.2.5.1 In this test, the receptor's field of view must always be larger than the projected area of the test specimen.

6.2.6 *Entrance Aperture*—The photoreceptor shall be provided with an entrance aperture of 43 mm maximum diameter. This is equivalent to 10 min angular aperture at 15 m. The physical size of the entrance aperture must be small so that the photoreceptor may be positioned physically close to the source exit aperture.

6.3 *Specimen Holder*—The specimen holder, commonly custom built to fit the desired specimen size and shape, must meet the following requirements (see Fig. 4 and Fig. 5).

⁸ The 1931 CIE Standard Photopic Observer is identical to the y-bar function of the 1931 CIE Standard Colorimetric Observer, which is tabulated in Practice E308, Table 1.

6.3.1 *Angular Accuracy*—The test surface must be positionable so that the entrance angle is accurate to within 0.5 % of its complement (that is, for 86° entrance angle, the angle must be accurate to $0.005 \times 4^\circ = 0.02^\circ$). This accuracy may be obtained by providing an optical means to align the test surface to 90° entrance angle and then adjusting to the desired entrance angle. (See Figs. 6-9 for examples of angular setting devices.)

6.3.2 *Entrance Angle Axis*—A means must be provided to change the entrance angle such that the axis of rotation is contained in the plane of the test surface if several entrance angles are to be used.

6.3.3 *Leading Edge Reflections*—The specimen holder must be provided with a means of eliminating reflections from the leading edge of the specimen, and the holder itself must be non-reflective.

6.3.4 *Incident Light Measurement Provision*—It is desirable that the specimen holder be such that the photoreceptor can easily be substituted for the specimen, which is required when incident light measurements are taken.

6.4 *Receptor-Source Support*—A device that adequately supports and separates the photoreceptor from the source at the observation position. The required accuracy of separation of the source exit aperture from the photoreceptor entrance aperture is dependent on the properties of the test specimen. For most horizontal surfacing materials, the divergence patterns are gradual and a positioning accuracy of ± 1 mm (or $\pm 0.5\%$ of the resolution) at 15 m test distance is adequate. A common method of fixing this distance is to provide a bar with holes machined in it at separations corresponding to the desired observation angles. In this method, the minimum practical observation angle is about 0.2°.

6.5 *Photometric Site*—Sufficient space is required so that the projector source and test surface can be separated by about 15 m. This facility must be such that stray light does not appreciably affect the test results. Flat black paint, black curtains, black tape, and other means shall be used to eliminate unwanted light and stray reflections.

7. Test Specimens

7.1 The preparation of test specimens is not described in this test method. For example, the user of the test method must describe a method of application of glass beads to a painted surface.

7.2 To obtain a flat surface, the test material is usually adhered to an aluminum backing or other suitable substrate so that the material lies flat for testing.

7.3 Typically, the area of the test specimen may be 100 by 450 mm or about 0.05 m².

8. Procedure

8.1 Set up the specimen holder so that the center of the test specimen is separated by approximately 15 m (test distances between 14 and 16 m are satisfactory) from the exit aperture of the light source. Measure the test distance accurately to within ± 10 mm. Align the specimen holder by optical means (auto-collimation) to the zero position so that the test surface is at a grazing angle to the source (that is, 90° entrance angle) (see