



Designation: **F2602 – 13 F2602 – 18**

Standard Test Method for Determining the Molar Mass of Chitosan and Chitosan Salts by Size Exclusion Chromatography with Multi-angle Light Scattering Detection (SEC-MALS)¹

This standard is issued under the fixed designation F2602; the number immediately following the designation indicates the year of original adoption or, in the case of revision, the year of last revision. A number in parentheses indicates the year of last reappraisal. A superscript epsilon (ϵ) indicates an editorial change since the last revision or reappraisal.

1. Scope

1.1 This test method covers the determination of the molar mass of chitosan and chitosan salts intended for use in biomedical and pharmaceutical applications as well as in tissue engineered medical products (TEMPs) by size exclusion chromatography with multi-angle laser light scattering detection (SEC-MALS). A guide for the characterization of chitosan salts has been published as Guide [F2103](#).

1.2 Chitosan and chitosan salts used in TEMP s should be well characterized, including the molar mass and polydispersity (molar mass distribution) in order to ensure uniformity and correct functionality in the final product. This test method will assist end users in choosing the correct chitosan for their particular application. Chitosan may have utility as a scaffold or matrix material for TEMP s, in cell and tissue encapsulation applications, and in drug delivery formulations.

1.3 The values stated in SI units are to be regarded as standard. No other units of measurement are included in this standard.

1.4 *This standard does not purport to address all of the safety concerns, if any, associated with its use. It is the responsibility of the user of this standard to establish appropriate safety, health, and environmental practices and determine the applicability of regulatory limitations prior to use.*

1.5 *This international standard was developed in accordance with internationally recognized principles on standardization established in the Decision on Principles for the Development of International Standards, Guides and Recommendations issued by the World Trade Organization Technical Barriers to Trade (TBT) Committee.*

2. Referenced Documents

2.1 *ASTM Standards:*²

[F2103 Guide for Characterization and Testing of Chitosan Salts as Starting Materials Intended for Use in Biomedical and Tissue-Engineered Medical Product Applications](#)

2.2 *United States Pharmacopeia/National Formulary:*³
[Chromatography](#)

2.2 *National Institute of Standards and Technology:*³

[NIST SP811 Special Publication: Guide for the Use of the International System of Units \(SI\)](#)

2.3 *ISO Document:*⁴

[ISO 80000-9:2009 Quantities and units – Part 9: Physical chemistry and molecular physics](#)

3. Terminology

3.1 *Definitions:*

¹ This test method is under the jurisdiction of ASTM Committee [F04](#) on Medical and Surgical Materials and Devices and is the direct responsibility of Subcommittee [F04.42](#) on Biomaterials and Biomolecules for TEMP s.

Current edition approved ~~Aug. 1, 2013~~ ~~June 1, 2018~~. Published ~~September 2013~~ ~~August 2018~~. Originally approved in 2008. Last previous edition approved in ~~2008~~ ~~2013~~ as ~~F2602-08-13~~. DOI: ~~10.1520/F2602-13~~. [10.1520/F2602-18](#).

² For referenced ASTM standards, visit the ASTM website, [www.astm.org](#), or contact ASTM Customer Service at [service@astm.org](#). For *Annual Book of ASTM Standards* volume information, refer to the standard's Document Summary page on the ASTM website.

³ Available from *United States Pharmacopeia and National Formulary*, U.S. Pharmaceutical Convention, Inc. (USPC), Rockville, MD.

³ Available from National Institute of Standards and Technology (NIST), 100 Bureau Dr., Stop 1070, Gaithersburg, MD 20899-1070, [http://physics.nist.gov/cuu/Units/bibliography.html](#).

⁴ Available from International Organization for Standardization (ISO), ISO Central Secretariat, BIBC II, Chemin de Blandonnet 8, CP 401, 1214 Vernier, Geneva, Switzerland, [http://www.iso.org](#).

3.1.1 *chitosan, n*—a linear polysaccharide consisting of $\beta(1\rightarrow4)$ linked 2-acetamido-2-deoxy-D-glucopyranose (GlcNAc) and 2-amino-2-deoxy-D-glucopyranose (GlcN). Chitosan is a polysaccharide derived by *N*-deacetylation of chitin.

3.1.1.1 *chitin, n*—a linear polysaccharide consisting of $\beta(1\rightarrow4)$ linked 2-acetamido-2-deoxy-D-glucopyranose.

3.1.2 *degree of deacetylation, n*—the fraction or percentage of glucosamine units (GlcN: deacetylated monomers) in a chitosan polymer molecule.

3.1.3 *molar mass average, n*—the given molar mass (*M*) of a chitosan will always represent an average of all of the molecules in the population. The most common ways to express the molar mass are as the *number average* (M_n^-) and the *mass average* (M_w^-). The two averages are defined by the following equations:

$$\bar{M}_n = \frac{\sum_i N_i M_i}{\sum_i N_i} \quad \text{and} \quad \bar{M}_w = \frac{\sum_i w_i M_i}{\sum_i w_i} = \frac{\sum_i N_i M_i^2}{\sum_i N_i M_i} \quad (1)$$

where:

N_i = number of molecules having a specific molar mass M_i , and

w_i = mass of molecules having a specific molar mass M_i .

3.1.3.1 Discussion—

In a polydisperse molecular population the relation $M_w^- > M_n^-$ is always valid. The coefficient ratio M_w^- / M_n^- is referred to as the polydispersity index, *dispersity*, and will typically be in the range 1.5 to 3.0 for commercial chitosans.

NOTE 1—The term molecular weight (abbreviated MW) is obsolete and should be replaced by the SI (Système Internationale) equivalent of either relative molecular mass (M_r), which reflects the dimensionless ratio of the mass of a single molecule to an atomic mass unit (see ISO 31-8; 80000-9:2009), or molar mass (M), which refers to the mass of a mole of a substance and is typically expressed as grams/mole. For polymers and other macromolecules, use of the symbols M_w , M_n , and M_z continue, referring to mass-average molar mass, number-average molar mass, and z-average molar mass, respectively. For more information regarding proper utilization of SI units, see NIST SP811.

4. Significance and Use

4.1 The degree of deacetylation of chitosan, as well as the molar mass and molar mass distribution, determines the functionality of chitosan in an application. For instance, functional and biological effects are highly dependent upon the composition and molar mass of the polymer.

4.2 This test method describes procedures for measurement of molar mass of chitosan chlorides and glutamates, and chitosan base, although it in principle applies to any chitosan salt. The measured molar mass is that for chitosan acetate, since the mobile phase contains acetate as counter ion. This value can further be converted into the corresponding molar mass for the chitosan as a base, or the parent salt form (chloride or glutamate).

4.3 Light scattering is one of very few methods available for the determination of absolute molar mass and structure, and it is applicable over the broadest range of molar masses of any method. Combining light scattering detection with size exclusion chromatography (SEC), which sorts molecules according to size, gives the ability to analyze polydisperse samples, as well as obtaining information on branching and molecular conformation. This means that both the number-average and mass-average values for molar mass and size may be obtained for most samples. Furthermore, one has the ability to calculate the distributions of the molar masses and sizes.

4.4 Multi-angle laser light scattering (MALS) is a technique where measurements of scattered light are made simultaneously over a range of different angles. MALS detection can be used to obtain information on molecular size, since this parameter is determined by the angular variation of the scattered light. Molar mass may in principle be determined by detecting scattered light at a single low angle (LALLS). However, advantages with MALS as compared to LALLS are: (1) less noise at larger angles, (2) the precision of measurements are greatly improved by detecting at several angles, and (3) the ability to detect angular variation allows determination of size, branching, aggregation, and molecular conformation.

4.5 Size exclusion chromatography uses columns, which are typically packed with polymer particles containing a network of uniform pores into which solute and solvent molecules can diffuse. While in the pores, molecules are effectively trapped and removed from the flow of the mobile phase. The average residence time in the pores depends upon the size of the solute molecules. Molecules that are larger than the average pore size of the packing are excluded and experience virtually no retention; these are eluted first, in the void volume of the column. Molecules, which may penetrate the pores will have a larger volume available for diffusion, they will suffer retention depending on be retained in the column for a time dependent upon their molecular size, with the smaller molecules eluting last after larger molecules.

4.6 For polyelectrolytes, dialysis against the elution buffer has been suggested, in order to eliminate Donnan-type artifacts in the molar mass determination by light scattering (1, 2).⁵ However, in the present method, the size exclusion chromatography step preceding the light scatter detection is an efficient substitute for a dialysis step. The sample is separated on SEC columns with large excess of elution buffer for 30 to 40 min, and it is therefore in full equilibrium with the elution buffer when it reaches the MALS detector.

5. Materials

5.1 Chemicals:

- 5.1.1 Chitosan or chitosan salt sample.
- 5.1.2 Deionized water (Milli-Q Plus or equivalent; conductivity < 10 μS/cm).
- 5.1.3 CH₃COONH₄ (ammonium acetate).
- 5.1.4 Pullulan standards. (See Note 2.)

NOTE 2—A series of linear homopolysaccharides with sufficiently narrow dispersity to be suitable for utilization as molar mass calibration standards in aqueous eluent.

5.2 Mobile Phase:

- 5.2.1 For SEC-MALS of chitosan and chitosan salts, a mobile phase stock solution of 0.40 mol/L CH₃COONH₄ in deionized water is prepared. Adjust the pH to 4.5 using acetic acid.
- 5.2.2 The mobile phase stock solution can be stored cool (3 to 8°C) for 6 months. Before use as a mobile phase, the stock solution is diluted 1:1 (v/v) with deionized water and passed through a 0.22 μm filter.

5.3 Instruments:

- 5.3.1 Analytical balance (0.1 mg).
- 5.3.2 Shaking device.
- 5.3.3 pH meter.
- 5.3.4 HPLC—High performance liquid chromatography (HPLC) system with injector, pump, degassing unit.
- 5.3.5 Size exclusion columns: TSK-Gel PW_{XL} columns from Tosoh Biosep., for example, PW_{XL}-guard column + G6000 PW_{XL} + G5000 PW_{XL} + G3000 PW_{XL} (last in the series), or equivalent.
- 5.3.6 Refractive Index (RI) detector, with a known calibration constant (dn/dV).
- 5.3.7 Multiple Angle Laser Light Scattering (MALS) detector, with known calibration constant.
- 5.3.8 Computer with suitable software.

6. Procedure

6.1 Preparation of Standards and Chitosan Salt Samples for SEC-MALS:

- 6.1.1 Samples are prepared at a concentration suitable for injection of 200 μL of sample (see Table 1 and Table 2).
- 6.1.2 Dissolve all samples in deionized water at twice the required concentration for molar mass determination by shaking at about 100 min⁻¹ overnight at cool temperature (3 to 8°C).
- 6.1.3 Dilute samples 1+1:1 with stock solution of mobile phase and shake gently for a few seconds.
- 6.1.4 Pass all samples through a 0.45 μm filter, and transfer to HPLC vials.
- 6.1.5 Final concentration of pullulan standards of known M_w^- values of approximately 11 800 to 47 300, 112 000, 212 000, and 404 000 g/mol should be approximately 4, 3, 2, and 1.5 mg/mL, respectively.
- 6.1.6 Guidelines for final concentration of chitosans for molar mass determination are given in Table 1. If SEC-MALS data display poor reproducibility is not reproducible with respect to replicates, this might be an indication of column overload. In this case, the sample should be injected diluted prior to injection.

6.2 Preparation of Chitosan Base Samples for SEC-MALS:

- 6.2.1 Samples are prepared at a concentration suitable for injection of 200 μL of sample (Table 3).

TABLE 1 Suggestions for Concentration and Injected Mass of Chitosan Chloride Samples for SEC-MALS

Apparent Viscosity as Chitosan Chloride (mPas)	Concentration for Injection (mg/mL)	Injected Mass ^A (mg)
<10	2	0.4
10–50	1	0.2
50–100	0.75	0.15
>100	0.5	0.1

^A Injected mass = Concentration*200 μL.

⁵ The boldface numbers in parentheses refer to a list of references at the end of this standard.

TABLE 2 Suggestions for Concentration and Injected Mass of Chitosan Glutamate Samples for SEC-MALS

Apparent Viscosity as Chitosan Glutamate (mPas)	Concentration for Injection (mg/mL)	Injected Mass ^A (mg)
<10	1.5	0.3
10–50	1	0.2
>50	0.75	0.15

^A Injected mass = Concentration*200 µL.

TABLE 3 Suggestions for Concentration and Injected Mass of Chitosan Base Samples for SEC-MALS

Apparent Viscosity as Chitosan Acetate (mPas)	Concentration for Injection (mg/mL)	Injected Mass ^A (mg)
<100	0.75	0.15
100–500	0.5	0.1
>500	0.375	0.075

^A Injected mass = Concentration*200 µL.

6.2.2 Dissolve the chitosan base in 1%–1 % (volume/volume) acetic acid to a 1%–1 % (weight/volume) solution by shaking at about 100 min⁻¹ overnight at cool temperature (3 to 8°C).

6.2.3 Dilute samples in mobile phase (Note 2) (2 mol/L ammonium acetate, not stock solution) to the required concentration (Table 3) and shake gently for a few seconds.

6.2.4 Filter all samples through a 0.45 µm filter, and transfer to HPLC vials.

6.3 *Chromatography and Data Collection:*

6.3.1 The complete experimental setup of the SEC-MALS system is shown in Fig. 1. The refractive index detector is placed at the end of the solvent/sample line as it is highly sensitive to pressure changes.

6.3.2 Pullulan standards should be injected and analyzed with 2 replicates before and after all chitosan samples (total of 4 replicates). Three (3) replicates should be injected for chitosans.

6.3.3 A procedure for setting up the chromatography run and collecting the data is given below:

6.3.3.1 Use a flow rate of 0.5 mL/min.

6.3.3.2 Purge the injector with mobile phase before the sample set is run.

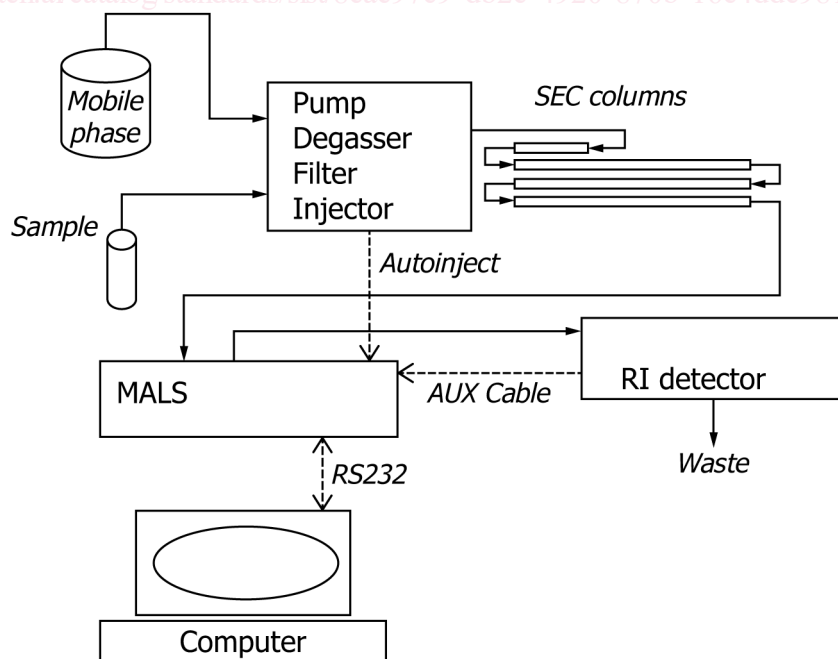

NOTE 1—Solid lines indicate solvent/sample flow, dashed lines indicate cabling for data transfer.

FIG. 1 Complete SEC-MALS Set-Up