



Designation: ~~C621 – 09 (Reapproved 2014)~~ C621 – 09 (Reapproved 2018)

Standard Test Method for Isothermal Corrosion Resistance of Refractories to Molten Glass¹

This standard is issued under the fixed designation C621; the number immediately following the designation indicates the year of original adoption or, in the case of revision, the year of last revision. A number in parentheses indicates the year of last reapproval. A superscript epsilon (ϵ) indicates an editorial change since the last revision or reapproval.

1. Scope

1.1 This test method covers the determination of the corrosion resistance of refractories in contact with molten glass under static, isothermal conditions.

1.2 The values stated in inch-pound units are to be regarded as standard. The values given in parentheses are mathematical conversions to SI units that are provided for information only and are not considered standard.

1.3 *This standard does not purport to address all of the safety concerns, if any, associated with its use. It is the responsibility of the user of this standard to establish appropriate safety, health, and environmental practices and determine the applicability of regulatory limitations prior to use.*

1.4 *This international standard was developed in accordance with internationally recognized principles on standardization established in the Decision on Principles for the Development of International Standards, Guides and Recommendations issued by the World Trade Organization Technical Barriers to Trade (TBT) Committee.*

2. Referenced Documents

2.1 *ASTM Standards:*²

E220 Test Method for Calibration of Thermocouples By Comparison Techniques

3. Significance and Use

3.1 This test method provides a rapid, inexpensive method for comparing the corrosion resistance of refractories. The isothermal conditions of this test method represent the most severe static corrosion environment possible at the specified test temperature. This test method is suitable for quality control, research and development applications, and for product value studies on similar materials. Tests run at a series of temperatures are often helpful in determining the use temperature limitations of a particular material. Melt-line corrosion results are also a useful indication of relative resistance to both upward and downward drilling corrosion mechanisms. Examination of test specimens also provides information about the tendency for a particular refractory to form stones or other glass defects.

3.2 Because this test method is both isothermal and static, and since most glass-contact refractories operate in a dynamic system with a thermal gradient, test results do not directly predict service in a furnace. The effects of differing thermal conductivities, refractory thickness, artificial cooling or insulation upon the refractory thermal gradient, and the erosive action of moving molten glass currents are not evaluated with this test.

4. Apparatus

4.1 *Glass-Melting Test Furnace*, heated with some type of electrical resistor (**Note 1**) and having a chamber large enough to receive four crucible assemblies of the type used in the test (**Fig. 1**) is required. The zone of the furnace in which the crucibles will rest should possess a maximum transverse thermal gradient of $\pm 1.8^\circ\text{F}$ ($\pm 1^\circ\text{C}$); $\pm 1.8^\circ\text{F}$ ($\pm 1^\circ\text{C}$). **Fig. A1.1** shows a schematic drawing of a furnace that is satisfactory for this test.

NOTE 1—It has been demonstrated that gas-fired furnaces show greater variability and higher average corrosion with this test method and are therefore generally unsuitable.

¹ This test method is under the jurisdiction of ASTM Committee C08 on Refractories and is the direct responsibility of Subcommittee C08.10 on Refractories for Glass. Current edition approved Sept. 1, 2014/Oct. 1, 2018. Published November 2014/October 2018. Originally approved in 1968. Last previous edition approved in 2009/2014 as C621 – 09/C621 – 09 (2014). DOI: 10.1520/C0621-09R14.10.1520/C0621-09R18.

² For referenced ASTM standards, visit the ASTM website, www.astm.org, or contact ASTM Customer Service at service@astm.org. For *Annual Book of ASTM Standards* volume information, refer to the standard's Document Summary page on the ASTM website.

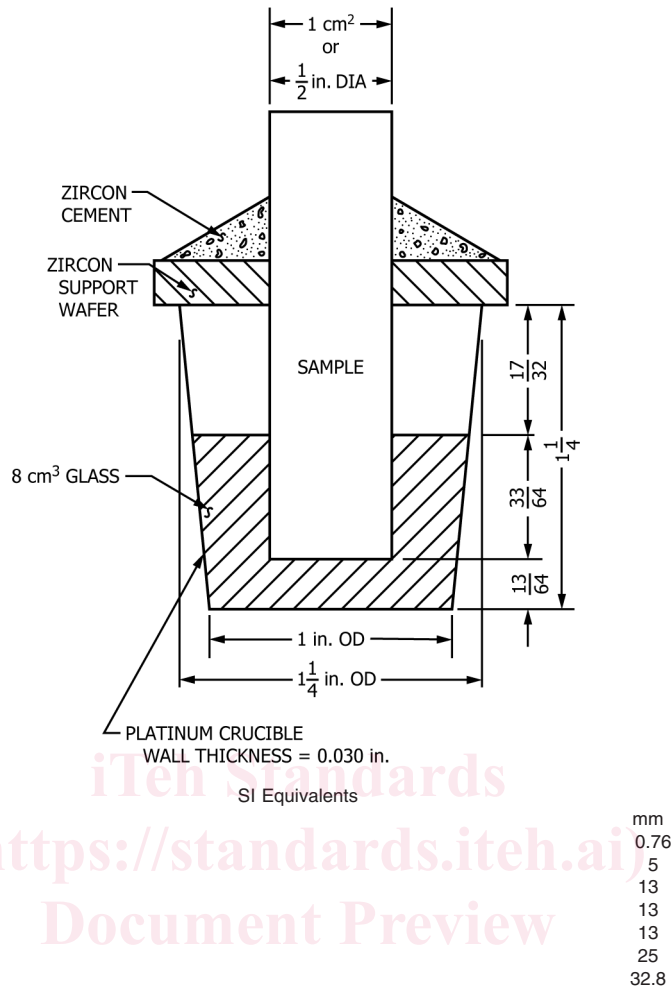

NOTE 1—All undesigned dimensions are in inches.

FIG. 1 Crucible – Assemblage

4.2 *Temperature-Control Instrumentation*, capable of maintaining the desired temperature to $\pm 1.8^\circ\text{F}$ ($\pm 1^\circ\text{C}$).

4.3 *Thermocouple*, for use as the temperature-measuring device. The type of thermocouple chosen will depend on the normal use temperature of the furnace. Since thermocouples age with a consequent drift in the signal fed to the control instrument, check the couple before each test run with a calibrated thermocouple. Test Method E220 specifies calibration procedures for thermocouples. If drift becomes severe, replace the thermocouple. Position the thermocouple hot junction in the furnace to coincide with the level of the glass line of the test samples.

4.4 *Platinum Crucibles* (Fig. 1).

4.5 *Sintered Zircon*, or other refractory wafers (Annex A2).

4.6 *Zircon Cement* (Annex A3).

4.7 *Measuring Microscope*.

4.8 *Tongs*, suitable for handling samples in the furnace (Fig. A1.6).

4.9 *Furnace*, for preheating test specimens to about 1832°F (1000°C).

4.10 *Diamond Saw*, and diamond hone, or diamond-core drill.

5. Test Specimens

5.1 *Sample Selection*—A sample shall be comprised of one or more specimens cut from the refractory unit being tested. Specimens should be as representative of the material being tested as possible. In the testing of slip-cast and pressed refractory products, take care to avoid cracks, checks, obvious contaminants, etc. In the testing of fusion-cast materials, it is recognized that

wide variations in both chemistry and crystal size occur within every casting. Therefore, a standard sampling location should be used and specified. For flat-cast blocks, take the specimen on the surface opposite the font scar (and perpendicular to this surface) and at least 3 in. (76 mm) from an end and a side of the casting. For voidless castings, take the specimen from any cast surface near the top, saw-cut surface of the block. Take this specimen at least 3 in. from any corner of the casting. Such specimens avoid edge and corner crystallization effects and have chemistries similar to those representing the bulk of the casting.

5.2 Specimen Size and Preparation:

5.2.1 The specimen shall be either 0.39 in. (9.9 mm) square by 2.0 in. (51 mm) long or cylinders 0.5 in. (13 mm) in diameter by 2.0 in. long. In either case, the specified dimensions shall be controlled within 0.002 in. (0.05 mm) along the entire length of the specimens.

5.2.2 Prepare cylindrical specimens with a diamond-core bit. Specimens should be perfectly smooth (free of small offsets, etc.) and free of metal marks from the drill along their entire length. Grind square specimens to size, after diamond sawing, on a diamond hone to provide clean parallel faces.

5.2.3 Do not grind the specimens with silicon carbide because of the potential contaminating effect.

5.2.4 After grinding or drilling, dry the specimens to constant weight at ~~230°F (110°C)~~ 230 °F (110 °C) prior to corrosion testing.

5.3 Pretest Specimen Measurements and Inspection:

5.3.1 Make a bulk density measurement on the specimen. Calculate the volume of the specimen either from the specimen dimensions or by water displacement.

5.3.2 Measure the specimen to the nearest 0.001 in. (~~0.03 mm~~) (0.03 mm) at two points, the anticipated glass line, and at a level halfway between the glass line and the bottom of the specimen. With square specimens, it is important that the orientation of these measurements be marked above the glass line so that corresponding measurements can be made after the test.

5.3.3 Make an inspection of the specimen prior to the test, noting color, evidence of porosity, and any irregularities or unusual features.

5.4 Other Specimen Notes:

5.4.1 Four or more specimens are usually tested concurrently. It has been found helpful to include a control (or standard) in each series of specimens. Ideally, the control specimens are taken from a single refractory block or shape retained semi-permanently for that purpose. By using a control specimen, the variability between tests can be continuously ~~scrutinized~~, scrutinized and the control specimen can serve as a comparison standard for the other specimen in the same test.

5.4.2 Either round or square test specimens may be used, but never both in the same series of experiments, since data from the two types of specimen geometry are not directly comparable.

5.4.3 Specimen orientation within a test or series of tests should be consistent. When applicable, cast or pressed surfaces should comprise the sample bottom.

6. Test Temperature and Duration

6.1 Test temperatures should simulate those in the intended service. ~~4807-b4b0-5a5ccc192f3/astm-c621-092018~~

6.2 For maximum reliability and reproducibility, the test time should be of sufficient duration to produce a ~~glass line~~ glass-line cut between 20 and 60 % of the original specimen thickness.

7. Procedure

7.1 *Mounting Specimens*—Mount specimens with the zircon wafers and zircon cement and center them in the crucible as shown in Fig. 1, so the bottom of the specimen will be $\frac{13}{64}$ in. (5 mm) from the bottom of the crucible.

7.1.1 Place a $\frac{13}{64}$ -in. (5-mm) ground wafer within and on the bottom of the crucible while the specimens are being cemented in place to obtain accurate spacing of the distance between the end of the specimen and the bottom of the crucible.

7.2 *Preheat*—Heat the mounted specimens, without the crucibles, in the preheat furnace to about ~~1830°F (1000°C)~~ 1830 °F (1000 °C). Simultaneously heat the crucibles charged with glass equivalent to 0.5 in.³ (8 cm³) to the selected testing temperature in the test furnace. Preheating minimizes specimen breakage from the thermal shock of immersion in hot glass.

7.3 Beginning the Test:

7.3.1 Transfer the test specimens from the preheat furnace with suitable tongs and insert them into the crucible filled with hot glass.

7.3.2 The time of the test begins when the furnace recovers to the preset test temperature.

7.3.3 At this time, make checks of the control thermocouple by probing the furnace with a calibrated thermocouple inserted through the hole provided in the center of the top and inner furnace plugs.

7.4 *Terminating the Test*—At the conclusion of the test, remove the crucibles from the furnace one at a time and quickly remove the specimen from the glass before the glass becomes too viscous.

7.5 Remove the support wafer and excess cement and cut the corroded specimens in half lengthwise (Fig. 2), using a thin diamond blade (Note 2). Care should be taken on square specimens so that the cut is made parallel to the measurements that were made before the test. Establish the glass line and a line ~~one-half~~ one-half the distance from glass line to the base of the specimen.

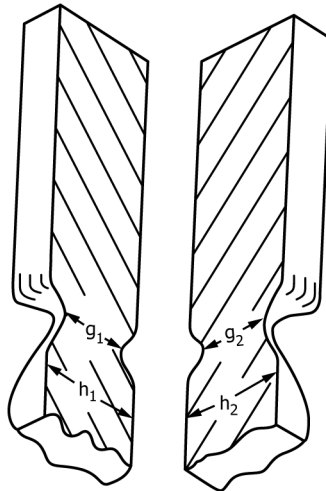

FIG. 2 View of Cut Specimen to Indicate Measurement After Test

Since the thickness of the saw blade can obviously influence the final test measurements, it is necessary that blade thickness be a constant at least within a specified tolerance. Therefore, the thickness of the diamond blade is arbitrarily specified at 0.056 ± 0.0005 in. (1.42 ± 0.013 mm), which coincides with the thickness of the most commonly used blade in small laboratory saws. Measure both halves of the specimen with a measuring microscope, with the specimen immersed in or coated with a liquid whose refractive index is the same as that of the test glass.

NOTE 2—It has been established that measurement of the specimens before splitting can result in large errors.

7.5.1 In the event of loose reaction interfaces on the test specimens, the measurement of remaining specimens thickness shall be made from the first material tightly adhering to the specimen. This is most important if corrosion values halfway down the specimen are to be reproducible. Therefore, a material might have a deep reaction interface, but as long as the interface remains an integral part of the specimen it is not reported as being corroded.

8. Calculation and Report

8.1 The calculations are not intended to show the reduction in cross-sectional area of the specimen, but the depth of corrosion.

8.1.1 Glass line corrosion is calculated as follows:

$$G_c = [G - \frac{1}{2}(g_1 + g_2)]/2$$

where:

- G_c = glass line corrosion,
- G = width or diameter of specimen at glass line, before test, mm, and
- g_1 and g_2 = width or diameter of the two halves of the cut specimen at the glass line, after test, measured on cut face, mm.

8.1.2 Half-down corrosion is calculated as follows:

$$H_c = [H - \frac{1}{2}(h_1 + h_2)]/2$$

where:

- H_c = half-down corrosion,
- H = width or diameter of specimen half way between glass line and bottom of sample, before test, mm, and
- h_1 and h_2 = width or diameter of the two halves of the cut specimen at the half-down level, after test, measured on cut face, mm.

8.2 An additional optional measurement on the unaltered portion of the sample above the support wafer made before and after the test will reveal any unusual shrinkage or growth phenomena that may have had some bearing on the result.

8.3 The test report should include the calculated results along with the glass used (and whether batch or cullet), the testing temperature, duration of the test, source, orientation and bulk density of each specimen, and a statement indicating either round or square cross-section. The corrosion may be reported in inches (millimetres) or as a percentage of the original sample width.

8.4 The use of commercially available platinum crucibles is common. These crucibles are typically larger in size and volume than those specified in 4.4 (Fig. 1). As a result, some laboratories also use larger glass volumes and/or specimens. A ruggedness test has shown that, with the standard specimen size and equal immersion depths, larger glass volumes