



Designation: **C99/C99M—15 C99/C99M – 18**

Standard Test Method for Modulus of Rupture of Dimension Stone¹

This standard is issued under the fixed designation C99/C99M; the number immediately following the designation indicates the year of original adoption or, in the case of revision, the year of last revision. A number in parentheses indicates the year of last reappraisal. A superscript epsilon (ϵ) indicates an editorial change since the last revision or reappraisal.

1. Scope

1.1 This test method covers the determination of the modulus of rupture of all types of dimension stone except slate.

1.2 The values stated in either SI units or inch-pound units are to be regarded separately as standard. The values stated in each system may not be exact equivalents; therefore, each system shall be used independently of the other. Combining values from the two systems may result in non-conformance with the standard.

1.3 *This standard does not purport to address all of the safety concerns, if any, associated with its use. It is the responsibility of the user of this standard to establish appropriate safety, health, and environmental practices and determine the applicability of regulatory limitations prior to use.*

1.4 *This international standard was developed in accordance with internationally recognized principles on standardization established in the Decision on Principles for the Development of International Standards, Guides and Recommendations issued by the World Trade Organization Technical Barriers to Trade (TBT) Committee.*

2. Referenced Documents

2.1 *ASTM Standards:*²

C119 Terminology Relating to Dimension Stone

C1799 Guide to Dimension Stone Test Specimen Sampling and Preparation

3. Terminology

3.1 *Definitions*—All definitions are in accordance with Terminology **C119**.

4. Significance and Use

4.1 This test method is useful in indicating the differences in modulus of rupture between the various dimension stones. This test method also provides one element in comparing stones of the same type.

5. Apparatus

5.1 *Testing Machine*—The accuracy of the testing machine shall be within 1 % for the range from 10 to 1000 lbf [50 to 5000 N].

5.2 *Load Application and Support Blocks*—The supports for the specimen shall be of the rocker type (**Fig. 1**) with edges at least as long as the width of the specimen. The load application block may be of either the rocker or rigid type. The portions of the load application and support blocks contacting the stone shall be rounded, with a nominal radius of ½ in. [13 mm].

6. Sampling

6.1 Select the sample to represent a true average of the type or grade of stone under consideration and of the quality supplied to the market under the type designation to be tested. The sample may be selected by the purchaser or his authorized representative from the quarried stone or taken from the natural ledge and shall be of adequate size to permit the preparation of the desired number of test specimens. When perceptible variations occur, the purchaser may select as many samples as are necessary for determining the variations in modulus of rupture.

NOTE 1—Refer to Guide **C1799** for additional information on selecting, preparing, and conditioning test specimens.

¹ This test method is under the jurisdiction of ASTM Committee **C18** on Dimension Stone and is the direct responsibility of Subcommittee **C18.01** on Test Methods. Current edition approved May 1, 2015/Oct. 1, 2018. Published July 2015/October 2018. Originally approved in 1931. Last previous edition approved in 2009/2015 as C99-09-15. DOI: 10.1520/C0099-C0099M-15-10.1520/C0099-C0099M-18.

² For referenced ASTM standards, visit the ASTM website, www.astm.org, or contact ASTM Customer Service at service@astm.org. For *Annual Book of ASTM Standards* volume information, refer to the standard's Document Summary page on the ASTM website.

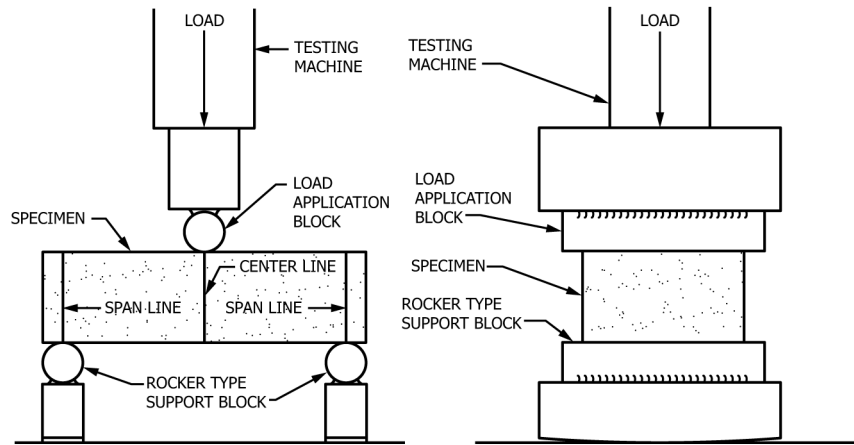

Specimen in Position for Testing

The test apparatus shown is one example of an acceptable configuration. Other configurations meeting the requirements of Section 5 are also acceptable.

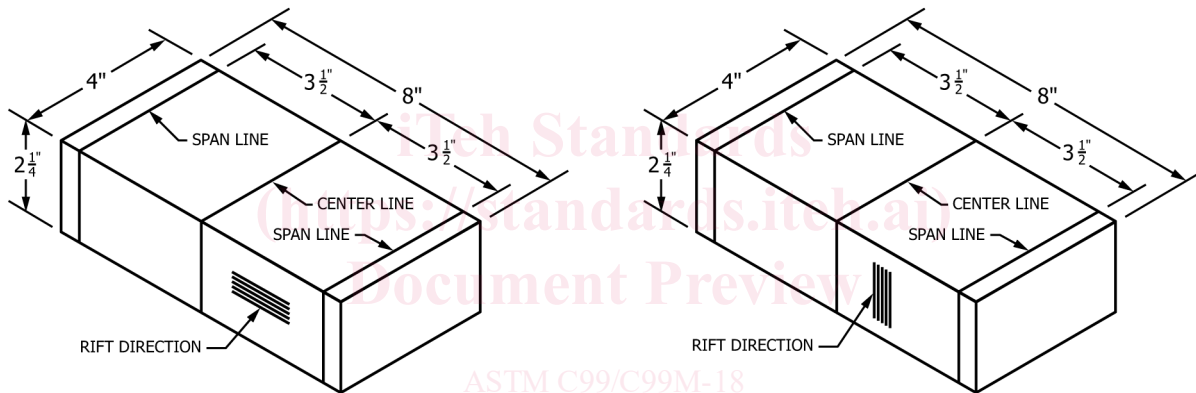

Specimen for Testing Perpendicular to Rift

Specimen for Testing Parallel to Rift

SI Unit Equivalents

2 1/4 in.	[60 mm]
3 1/2 in.	[90 mm]
4 in.	[100 mm]
8 in.	[200 mm]

FIG. 1 Specimens and Preferred Type of Load Application and Support Blocks for Determining the Modulus of Rupture of Building Stone

7. Test Specimens

7.1 The specimens shall be 4 by 8 by 2 1/4 in. [100 by 200 by 60 mm] in size and fabricated to tolerances of ± 1/16 in. [± 2 mm]. They shall be sawed from the sample and finished by grinding to smooth surfaces. The 4 by 8-in. [100 by 200-mm] faces shall be as nearly plane and parallel as practicable. For loading perpendicular to the rift (Note 2) five specimens shall be prepared with the 4 by 8-in. [100 by 200-mm] faces parallel to the rift planes (see Fig. 1), and for loading parallel to the rift, five specimens shall be prepared with the 4 by 2 1/4-in. [100 by 60-mm] faces parallel to the rift (Note 3). When tests are desired on the stone in both the wet and dry condition, ten specimens shall be prepared for each direction of loading; that is, five for tests dry, perpendicular to the rift, five for tests wet, perpendicular to the rift, etc.

NOTE 2—The term rift is used here to designate the direction in which the stone splits most easily. In stratified stones it is considered to coincide with the bedding or stratification. The rift direction should always be marked on the sample by the quarryman, since it often is not possible to determine it on a small block.

NOTE 3—Another condition of loading may occur in structures when the rift planes are vertical and parallel to the length of the beam. The strength of the stone may be obtained for such loading by cutting the specimens with the 2 1/4 by 8-in. [60 by 200-mm] face parallel to the rift. The meager data