



Designation: **C1202—17a C1202 – 18**

## Standard Test Method for Electrical Indication of Concrete's Ability to Resist Chloride Ion Penetration<sup>1</sup>

This standard is issued under the fixed designation C1202; the number immediately following the designation indicates the year of original adoption or, in the case of revision, the year of last revision. A number in parentheses indicates the year of last reapproval. A superscript epsilon ( $\epsilon$ ) indicates an editorial change since the last revision or reapproval.

### 1. Scope\*

1.1 This test method covers the determination of the electrical conductance of concrete to provide a rapid indication of its resistance to the penetration of chloride ions. This test method is applicable to types of concrete where correlations have been established between this test procedure and long-term chloride ponding procedures such as those described in AASHTO T 259. Examples of such correlations are discussed in Refs **1-5**.<sup>2</sup>

1.2 The values stated in SI units are to be regarded as standard. No other units of measurement are included in this standard.

1.3 The text of this standard references notes and footnotes which provide explanatory material. These notes and footnotes (excluding those in tables and figures) shall not be considered as requirements of the standard.

1.4 *This standard does not purport to address all of the safety concerns, if any, associated with its use. It is the responsibility of the user of this standard to establish appropriate ~~safety~~ safety, health, and ~~health~~ environmental practices and determine the applicability of regulatory limitations prior to use.*

1.5 *This international standard was developed in accordance with internationally recognized principles on standardization established in the Decision on Principles for the Development of International Standards, Guides and Recommendations issued by the World Trade Organization Technical Barriers to Trade (TBT) Committee.*

### 2. Referenced Documents

2.1 *ASTM Standards*:<sup>3</sup>

**C31/C31M** Practice for Making and Curing Concrete Test Specimens in the Field

**C42/C42M** Test Method for Obtaining and Testing Drilled Cores and Sawed Beams of Concrete

**C192/C192M** Practice for Making and Curing Concrete Test Specimens in the Laboratory

**C670** Practice for Preparing Precision and Bias Statements for Test Methods for Construction Materials

**C802** Practice for Conducting an Interlaboratory Test Program to Determine the Precision of Test Methods for Construction Materials

2.2 *AASHTO Standard*:

**T 259** Method of Test for Resistance of Concrete to Chloride Ion Penetration<sup>4</sup>

### 3. Summary of Test Method

3.1 This test method consists of monitoring the amount of electrical current passed through 50-mm thick slices of 100-mm nominal diameter cores or cylinders during a 6-h period. A potential difference of 60 V dc is maintained across the ends of the specimen, one of which is immersed in a sodium chloride solution, the other in a sodium hydroxide solution. The total charge passed, in coulombs, has been found to be related to the resistance of the specimen to chloride ion penetration.

<sup>1</sup> This test method is under the jurisdiction of ASTM Committee C09 on Concrete and Concrete Aggregates and is the direct responsibility of Subcommittee C09.66 on Concrete's Resistance to Fluid Penetration.

Current edition approved Dec. 1, 2017/July 1, 2018. Published December 2017/October 2018. Originally approved in 1991. Last previous edition approved in 2017 as C1202 – 17-17a. DOI: 10.1520/C1202-17A; 10.1520/C1202-18.

<sup>2</sup> The boldface numbers in parentheses refer to the list of references at the end of this standard.

<sup>3</sup> For referenced ASTM standards, visit the ASTM website, www.astm.org, or contact ASTM Customer Service at service@astm.org. For *Annual Book of ASTM Standards* volume information, refer to the standard's Document Summary page on the ASTM website.

<sup>4</sup> Methods of Sampling and Testing, 1986, American Association of State Highway and Transportation Officials, 444 N. Capitol St., NW, Washington, DC 20001.

\*A Summary of Changes section appears at the end of this standard

## 4. Significance and Use

4.1 This test method covers the laboratory evaluation of the electrical conductance of concrete samples to provide a rapid indication of their resistance to chloride ion penetration. In most cases the electrical conductance results have shown good correlation with chloride ponding tests, such as AASHTO T259, on companion slabs cast from the same concrete mixtures (Refs 1-5).

4.2 This test method is suitable for evaluation of materials and material proportions for design purposes and research and development.

4.3 Sample age has significant effects on the test results, depending on the type of concrete and the curing procedure. Most concretes, if properly cured, become progressively and significantly less permeable with time.

4.4 This test method was developed originally for evaluations of alternative materials, but in practice its use has evolved to applications such as quality control and acceptance testing. Factors such as ingredient materials used in concrete mixtures and the method and duration of curing test specimens affect the results of this test (See Note 1). When this method is used for mixture qualification and acceptance testing, it is imperative that the curing procedures and the age at time of testing be clearly specified.

NOTE 1—When using this test for determining acceptability of concrete mixtures, statistically-based criteria and test age for prequalification, or for acceptance based on jobsite samples, should be stated in project specifications. Acceptance criteria for this test should consider the sources of variability affecting the results and ensure balanced risk between supplier and purchaser. The anticipated exposure conditions and time before a structure will be put into service should be considered. One approach to establishing criteria is discussed in Ref 6.

4.5 Table X1.1 in Appendix X1 provides a qualitative relationship between the results of this test and the chloride ion penetrability of concrete.

4.6 Care should be taken in interpreting results of this test when it is used on surface-treated concretes, for example, concretes treated with penetrating sealers. The results from this test on some such concretes indicate low resistance to chloride ion penetration, while 90-day chloride ponding tests on companion slabs show a higher resistance.

4.7 The details of the test method apply to 100-mm nominal diameter specimens. This includes specimens with actual diameters ranging from 95 to 100 mm. Other specimen diameters may be tested with appropriate changes in the applied voltage cell design (see 7.5 and Fig. 1).

4.7.1 For specimen diameters other than 95 mm, the test result value for total charge passed must be adjusted following the procedure in 11.2. For specimens with diameters less than 95 mm, particular care must be taken in coating and mounting the specimens to ensure that the conductive solutions are able to contact the entire end areas during the test.

## 5. Interferences

5.1 This test method can produce misleading results when calcium nitrite has been admixed into a concrete. The results from this test on some such concretes indicate higher coulomb values, that is, lower resistance to chloride ion penetration, than from tests on identical concrete mixtures (controls) without calcium nitrite. However, long-term chloride ponding tests indicate the concretes with calcium nitrite were at least as resistant to chloride ion penetration as the control mixtures.

NOTE 2—Other admixtures might affect results of this test similarly. Long term ponding tests are recommended if an admixture effect is suspected.

5.2 Since the test results are a function of the electrical resistance of the specimen, the presence of reinforcing steel or other embedded electrically conductive materials may have a significant effect. The test is not valid for specimens containing reinforcing steel positioned longitudinally, that is, providing a continuous electrical path between the two ends of the specimen.

## 6. Apparatus

6.1 *Vacuum Saturation Apparatus* (see Fig. 2 for example):

6.1.1 *Separatory Funnel*, or other sealable, bottom-draining container with a minimum capacity of 500 mL.

6.1.2 *Beaker (1000 mL or larger) or other container*—Capable of holding concrete specimen(s) and water and of fitting into vacuum desiccator (see 6.1.3).

6.1.3 *Vacuum Desiccator*—The volume of desiccator shall be large enough to maintain sample immersion throughout the saturation process. Desiccator must allow two hose connections through a rubber stopper and sleeve or through a rubber stopper only. Each connection must be equipped with a stopcock.

6.1.4 *Vacuum Pump or Aspirator*—Capable of maintaining an absolute pressure of less than 50 mm Hg (6650 Pa) in desiccator (see Note 4).

NOTE 3—Because vacuum will be drawn over water, a vacuum pump should be protected with a water trap, or pump oil should be changed after each operation.

NOTE 4—Absolute pressure is zero-referenced against a perfect vacuum. At sea level, atmospheric pressure is an absolute pressure of 760 mm Hg. Gauge pressure is zero-referenced against atmospheric air pressure, so it is equal to the absolute pressure minus atmospheric pressure. An absolute pressure of 50 mm Hg will correspond to a gauge pressure of -710 mm at sea level. Some gauges may display this value as +710 mm.

6.1.5 *Vacuum Gauge or Manometer*—Accurate to the nearest  $\pm 5$  mm Hg ( $\pm 665$  Pa) over range 0–100 mm Hg (0–13300 Pa) the entire of measured pressure.

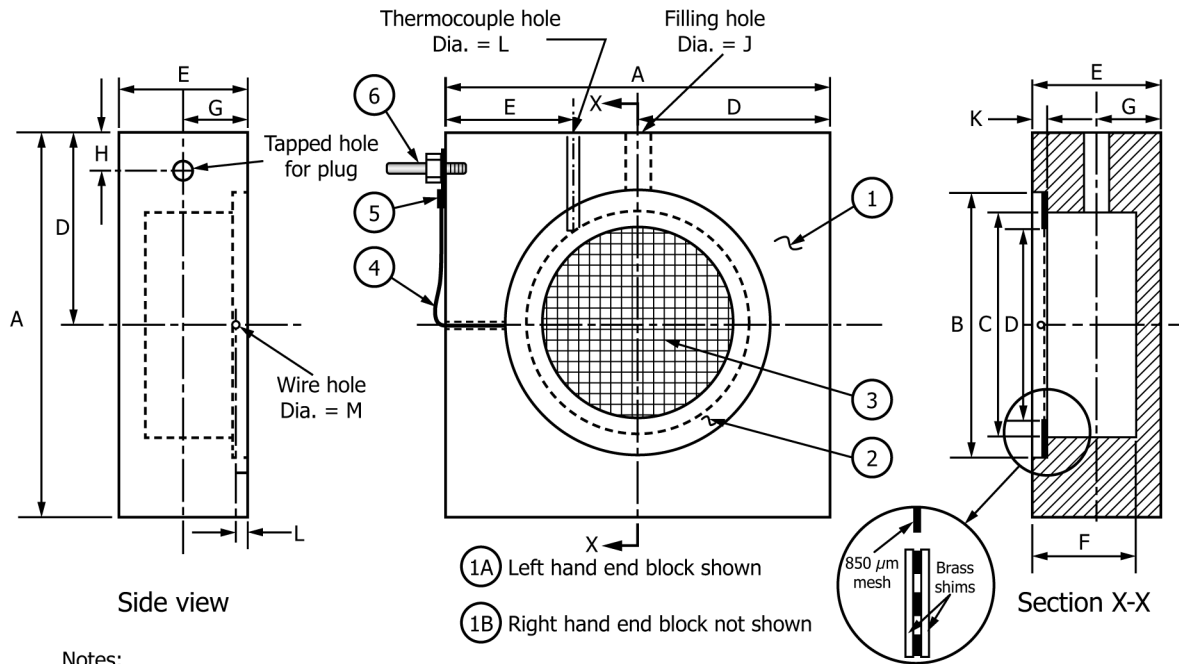

Notes:  
 Seal wire in hole with silicone rubber  
 Solder screen between shims  
 Solder wire to shim

Dimensions, mm

A	B	C	D	E	F	G	H	J	K	L	M
150	105	89	75	50	41	25	15	10	6	5	2.5

Parts List

Item No.	Quantity	Description	Specification
1A 1B	1 1	Cell block end	Poly (methyl methacrylate)
2	4	Brass shim	0.5 mm thick
3	2	Brass screen	850 μm (No. 20) mesh
4	2	Solid copper wire	2 mm (14 gauge) nylon cladding
5	2	Ring terminal	For 2 mm (14 gauge) wire
6	2	Banana plug	6.4 mm with threaded stud

FIG. 1 Applied Voltage Cell (Construction Drawing)

6.2 Coating Apparatus and Materials:

- 6.2.1 Coating—Rapid setting, electrically nonconductive, capable of sealing side surface of concrete cores.
- 6.2.2 Balance or Scale, Paper Cups, Wooden Spatulas, and Disposable Brushes—For mixing and applying coating.

6.3 Specimen Sizing Equipment (not required if samples are cast to final specimen size).

- 6.3.1 Movable Bed Water-Cooled Diamond Saw or Silicon Carbide Saw.

7. Reagents, Materials, and Test Cell

7.1 Specimen-Cell Sealant—Capable of sealing concrete to poly (methyl methacrylate), for example, Plexiglas, against water and dilute sodium hydroxide and sodium chloride solutions at temperatures up to 90°C; 90°C; examples include RTV silicone rubbers, silicone rubber caulking, other synthetic rubber sealants, silicone greases, and rubber gaskets.

7.2 Sodium Chloride Solution—3.0 % by mass (reagent grade) in distilled water.

7.3 Sodium Hydroxide Solution—0.3 N (reagent grade) in distilled water.

7.3.1 Bring the NaOH solution to room temperature prior to use (Note 45).

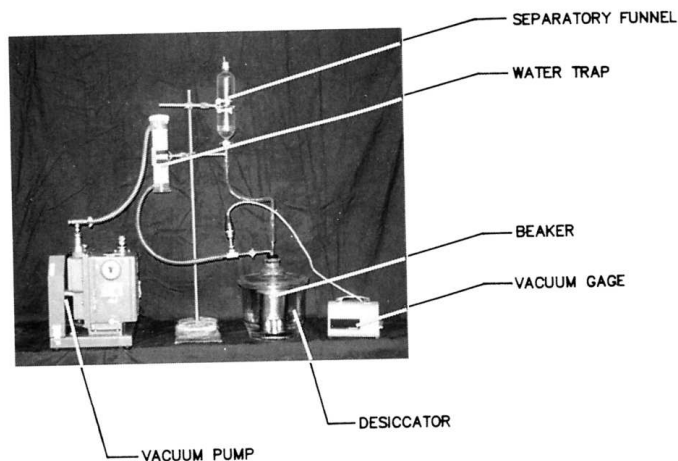

FIG. 2 Vacuum Saturation Apparatus

NOTE 5—Mixing 0.3 N NaOH solution generates heat, affecting the conductivity of the solution and the results of the test.

7.3.2 **Warning**—Before using NaOH, review: (1) the safety precautions for using NaOH; (2) first aid for burns; and (3) the emergency response to spills, as described in the manufacturer’s Material Safety Data Sheet or other reliable safety literature. NaOH can cause very severe burns and injury to unprotected skin and eyes. Suitable personal protective equipment should always be used. These should include full-face shields, rubber aprons, and gloves impervious to NaOH. Gloves should be checked periodically for pin holes.

7.4 *Filter Papers*—No. 2, 90-mm diameter (not required if rubber gasket is used for sealant (see 7.1) or if sealant can be applied without overflowing from shim onto mesh).

7.5 *Applied Voltage Cell* (see Fig. 1 and Fig. 3)—Two symmetric poly (methyl methacrylate) chambers, each containing electrically conductive mesh and external connectors. One design in common use is shown in Fig. 1 and Fig. 3. However, other designs are acceptable, provided that overall dimensions (including dimensions of the fluid reservoir) are the same as shown in Fig. 1 and width of the screen and shims are as shown.

7.6 *Temperature Measuring Device (optional)*—0 to 120°C range.

7.7 *Voltage Application and Data Readout Apparatus*—Capable of holding  $60 \pm 0.1$  V dc across applied voltage cell over entire range of currents and of displaying voltage accurate to  $\pm 0.1$  V and current to  $\pm 1$  mA. Apparatus listed in 7.7.1 – 7.7.5 is a possible system meeting this requirement.

7.7.1 *Voltmeter*—Digital (DVM), 3 digit, minimum 0–99.9 V range, rated accuracy  $\pm 0.1$  %.

7.7.2 *Voltmeter*—Digital (DVM), 4½ digit, 0–200 mV range, rated accuracy  $\pm 0.1$  %.

7.7.3 *Shunt Resistor*—100 mV, 10A rating, tolerance  $\pm 0.1$  %. Alternatively, a 0.01  $\Omega$  resistor, tolerance  $\pm 0.1$  %, may be used, but care must be taken to establish very low resistance connections.

7.7.4 *Constant Voltage Power Supply*—0–80 V dc, 0–2 A, capable of holding voltage constant at  $60 \pm 0.1$  V over entire range of currents.

7.7.5 *Cable*—Two conductor, AWG No. 14 (1.6 mm), insulated, 600 V.

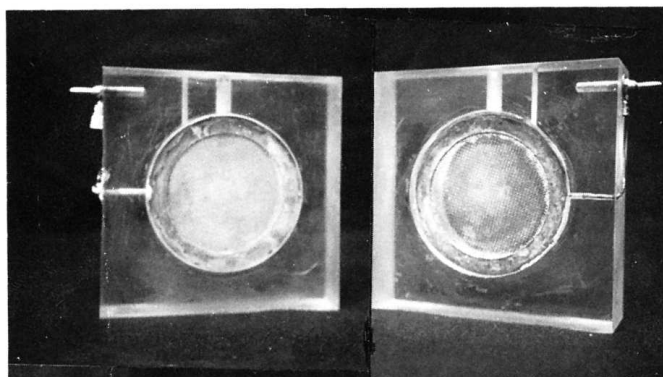

FIG. 3 Applied Voltage Cell-Face View