

INTERNATIONAL ELECTROTECHNICAL COMMISSION  
COMMISSION ÉLECTROTECHNIQUE INTERNATIONALE

---

**IEC 61215-2**  
Edition 1.0 2016-03

**TERRESTRIAL PHOTOVOLTAIC (PV) MODULES –  
DESIGN QUALIFICATION AND TYPE APPROVAL**

**Part 2: Test procedures**

**IEC 61215-2**  
Édition 1.0 2016-03

**MODULES PHOTOVOLTAIQUES (PV) POUR  
APPLICATIONS TERRESTRES – QUALIFICATION  
DE LA CONCEPTION ET HOMOLOGATION**

**Partie 2: Procédures d'essai**

**CORRIGENDUM 1**

Corrections to the French version appear after the English text.

Les corrections à la version française sont données après le texte anglais.

**4.9.4 Apparatus**

*Replace:*

a) "Radiant source: Natural sunlight, or a class BBB (or better) steady-state solar simulator conforming to IEC 60904-9 with an irradiance of  $(1\,000 \pm 100)$  W/m<sup>2</sup>."

*By:*

a) "Radiant source: Natural sunlight, or a class BBB (or better) steady-state solar simulator conforming to IEC 60904-9 with an irradiance of 800 W/m<sup>2</sup> to 1 100 W/m<sup>2</sup>."

**4.9.5.3.1 General**

*Replace:*

"The hot-spot test is performed with the module exposed to 800 W/m<sup>2</sup> to 1 000 W/m<sup>2</sup>."

*By:*

"The hot-spot test is performed with the module exposed to  $(1\,000 \pm 100)$  W/m<sup>2</sup>."

### 4.14.3 Test of cord anchorage (MQT 14.2)

Replace:

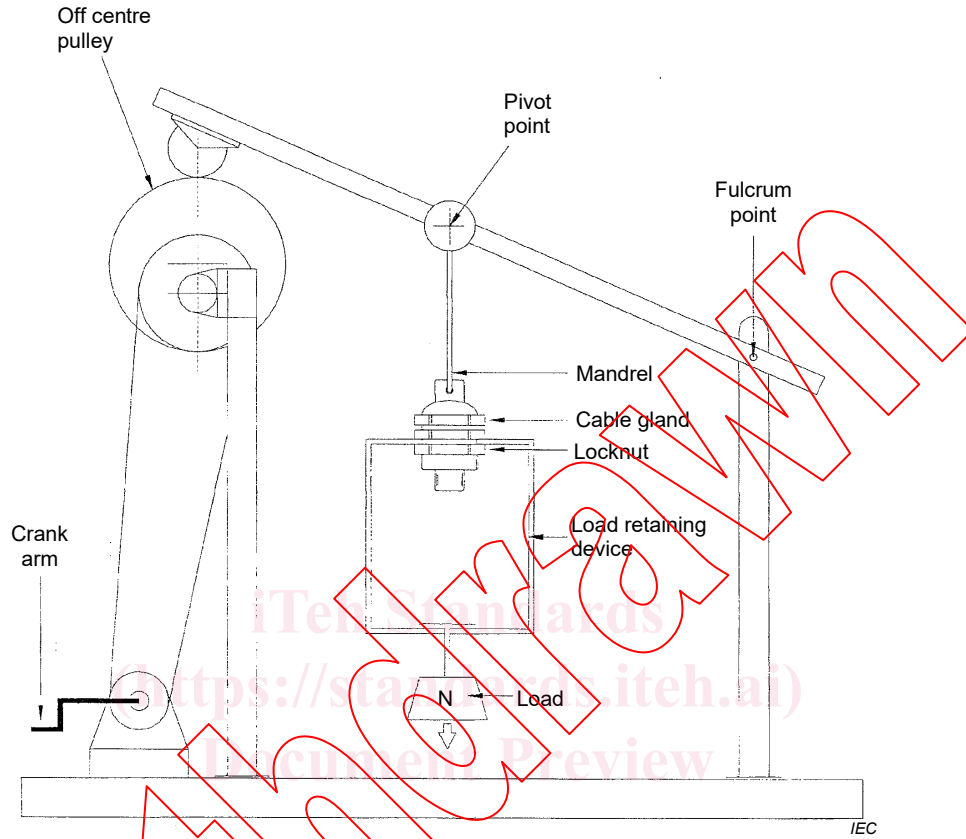

NOTE For module testing setup depends on the module construction.

**Figure 11 – Typical arrangement for the cord anchorage pull test for component testing**

By:

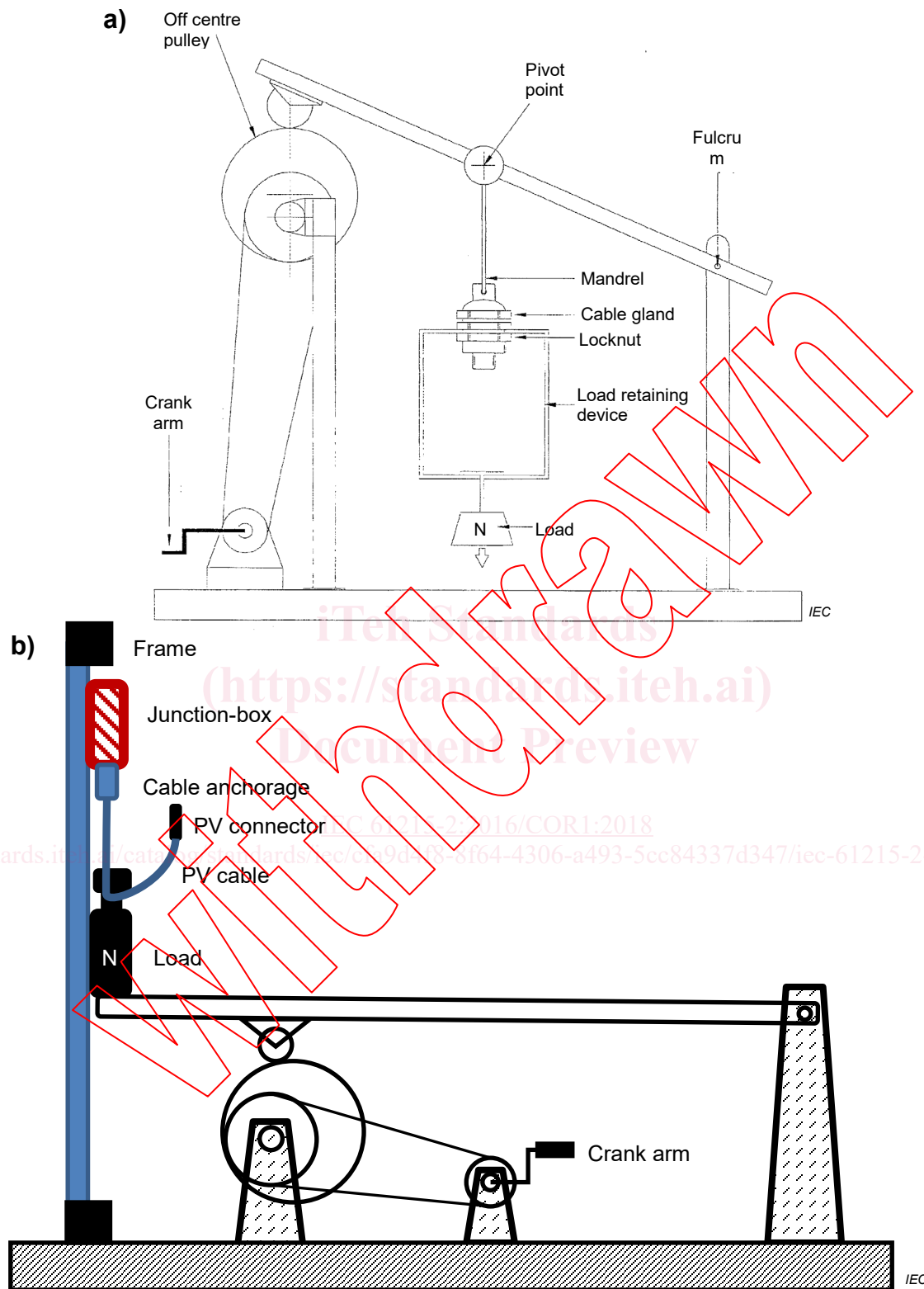

Figure 11 – a) Typical arrangement for the cord anchorage pull test for component testing from IEC 62790. b) Typical schematic arrangement for cord anchorage pull test on PV module mounted junction box

Replace:

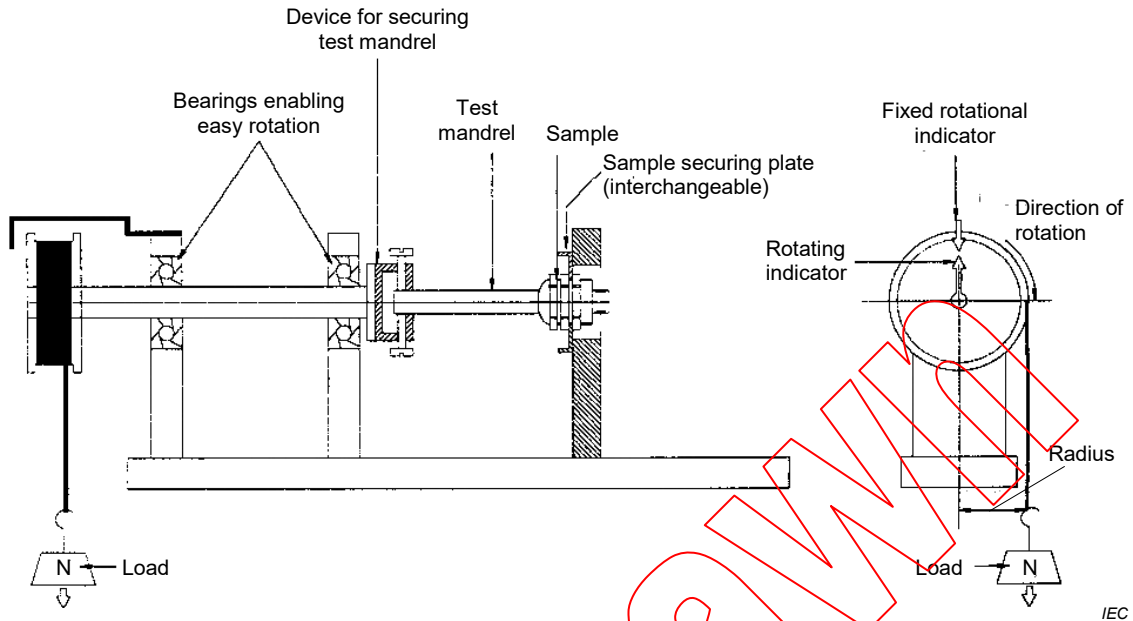
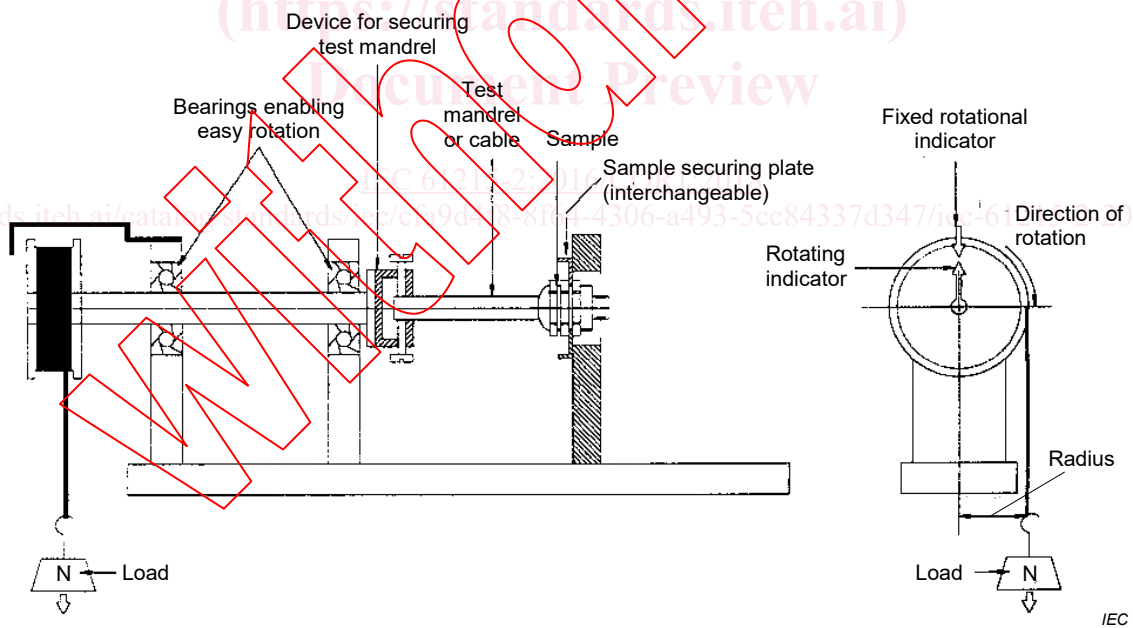

Figure 12 – Typical arrangement for torsion test

By:



If the test is performed with the manufacturer's cable, the fixture for securing the cable shall be as close as possible to the cable securing plate of the junction box.

Figure 12 – Typical arrangement for torsion test

#### 4.17.3 Procedure

**Table 4 – Impact locations**

*Replace:*

3, 4	Over edges of the circuit (e.g. individual cells).
5, 6	Over the circuit near interconnects (i.e. cell interconnects and bus ribbons).

*By:*

3, 4	Over the circuit near interconnects (i.e. cell interconnects and bus ribbons).
5, 6	Over edges of the circuit (e.g. individual cells).

WITHDRAWN

iTech Standards  
(<https://standards.iteh.ai>)  
Document Preview

Corrections à la version française:

#### 4.9.4 Appareillage

*Remplacer:*

a) "Source de rayonnement : Éclairement solaire naturel, ou simulateur solaire à éclairement continu de classe BBB minimum conforme à l'IEC 60904-9 produisant un éclairement de  $(1\ 000 \pm 100)$  W/m<sup>2</sup>."

*par:*

a) "Source de rayonnement : Éclairement solaire naturel, ou simulateur solaire à éclairement continu de classe BBB minimum conforme à l'IEC 60904-9 produisant un éclairement de 800 W/m<sup>2</sup> à 1 100 W/m<sup>2</sup>."

#### 4.9.5.3.1 Généralités

*Remplacer:*

"L'essai de tenue à l'échauffement localisé est réalisé avec le module exposé à un éclairement compris entre 800 W/m<sup>2</sup> et 1 000 W/m<sup>2</sup>."

*par:*

"L'essai de tenue à l'échauffement localisé est réalisé avec le module exposé à un éclairement compris entre  $(1\ 000 \pm 100)$  W/m<sup>2</sup>."