



Standard Specification for Manually Operated Fueling Hose Reels¹

This standard is issued under the fixed designation F1347; the number immediately following the designation indicates the year of original adoption or, in the case of revision, the year of last revision. A number in parentheses indicates the year of last reapproval. A superscript epsilon (ϵ) indicates an editorial change since the last revision or reapproval.

This standard has been approved for use by agencies of the U.S. Department of Defense.

1. Scope

1.1 This specification covers manually operated fueling hose reels for use with collapsible and noncollapsible hose.

1.2 The values stated in inch-pound units are to be regarded as standard. The values given in parentheses are mathematical conversions to SI units that are provided for information only and are not considered standard.

1.3 The following precautionary caveat pertains only to the test methods portion, Section 12 of this specification: *This standard does not purport to address all of the safety concerns, if any, associated with its use. It is the responsibility of the user of this standard to establish appropriate safety, health, and environmental practices and determine the applicability of regulatory limitations prior to use.*

1.4 *This international standard was developed in accordance with internationally recognized principles on standardization established in the Decision on Principles for the Development of International Standards, Guides and Recommendations issued by the World Trade Organization Technical Barriers to Trade (TBT) Committee.*

2. Referenced Documents

2.1 ASTM Standards:²

- B148 Specification for Aluminum-Bronze Sand Castings
- D3006 Specification for Polyethylene Plastic Pressure-Sensitive Electrical Insulating Tape
- D3951 Practice for Commercial Packaging

2.2 Military Specifications:³

- MIL-S-901 Shock Test, H.I. (High-Impact); Shipboard Machinery, Equipment and Systems, Requirements for

¹ This specification is under the jurisdiction of ASTM Committee F25 on Ships and Marine Technology and is the direct responsibility of Subcommittee F25.07 on General Requirements.

Current edition approved Oct. 1, 2018. Published October 2018. Originally approved in 1991. Last previous edition approved in 2012 as F1347 – 91 (2012). DOI: 10.1520/F1347-91R18.

² For referenced ASTM standards, visit the ASTM website, www.astm.org, or contact ASTM Customer Service at service@astm.org. For *Annual Book of ASTM Standards* volume information, refer to the standard's Document Summary page on the ASTM website.

³ Available from DLA Document Services, Building 4/D, 700 Robbins Ave., Philadelphia, PA 19111-5094, <http://quicksearch.dla.mil>.

- MIL-T-16366 Terminals, Electric Lug and Conductor Splices, Crimp Style
- MIL-H-17902 Hose, End Fittings and Hose Assemblies, Synthetic Rubber, Aircraft Fuels
- MIL-F-20042 Flanges, Pipe and Bulkhead, Bronze (Silver Brazing)
- MIL-P-24441 Epoxy-Polyamide Primer
- 2.3 *Military Standard:*³
- MIL-STD-130 Identification Marking of U.S. Military Property

3. Classification

3.1 Fueling hose reels shall be of one of the following types as specified:

3.1.1 *Type 1*—For 150 ft (46 m) of collapsible 2½-in. (65-mm) hose.

3.1.2 *Type 2*—For 150 ft (46 m) of noncollapsible 1½-in. (38-mm) hose or 100 ft (30 m) of noncollapsible 2-in. (50-mm) hose.

3.1.3 *Type 3*—For 150 ft (46 m) of noncollapsible 1½-in. (38-mm) hose or for 150 ft (46 m) of collapsible 2½-in. (65-mm) hose.

3.1.4 *Type 4*—Capacity as specified by purchaser.

4. Ordering Information

4.1 Orders for material under this specification shall include the following information:

- 4.1.1 Title, number, and year of issue of this specification,
- 4.1.2 Type of hose reel including hose size and type (see 3.1), (length of hose for Type 4),
- 4.1.3 Whether right- or left-hand reels are required (see 6.5),
- 4.1.4 Flange inlet thickness and bolt hole dimensions (see 6.7),
- 4.1.5 Drawings required (see 9.1),
- 4.1.6 The number of samples to be inspected and tested (see 11.2),
- 4.1.7 Certification, if required (see 15.1),
- 4.1.8 Test report, if required (see 15.1), and
- 4.1.9 Applicability of supplementary requirements.

5. Materials and Manufacture

5.1 Except as otherwise specified herein, the hose reels shall be constructed of aluminum, aluminum bronze, or other

suitable nonsparking materials. All fittings conveying aromatic fuels through the hose reel shall be made of aluminum bronze in accordance with Specification B148, copper alloy UNS No. C95300. To prevent deterioration in sea atmosphere, aluminum parts should not contact brass or bronze; however, where such aluminum parts come in contact with brass or bronze, they shall be protected by adhesive-backed insulating tape, Specification D3006. All aluminum parts shall be given a coat of epoxy-polyamide primer.

6. Construction

6.1 Reel and Drum Assembly—The hose reel shall be of a durable, rigid construction, as light in weight and compact as practicable. The drum assembly (drum, reel sides, and its reinforcements) shall withstand the hose pull without distortion or collapse and shall be capable of withstanding some sideways hose pull without undue distortions. The construction of the completed drum assembly shall be such that disassembly can be readily accomplished with standard tools. When bolted down to a true flat surface, the shaft and rotating seal centerlines shall be in true alignment and the drum assembly shall turn without binding under a rim pull not to exceed 7 lb (198 kg) with the reel unpressurized. Both ends of the drum shaft shall be supported on ball or roller bearings that shall have provision for easy lubrication. Reels shall be designed so that all bearings, and other corrodible parts, are adequately protected from the weather. Provision shall be made for lubrication of working parts such as bearings or other mating

surfaces, and all such parts shall be lubricated before delivery with a lubricant soluble in aromatic fuels. Bearing seals shall be such that the pressure caused by forced lubrication will not bind the shaft.

6.2 Reel Drum—The reel drum may have either smoothly formed flat sides or suitable spoke ribs, so formed as not to damage the hose. The rims of the drum shall provide a good grip for hand rewind.

6.3 Holding Brake—Reels shall be provided with a holding brake to lock the reel in any position.

6.4 Nozzle Clamp—The reel shall be fitted with a device for clamping the hose nozzle securely to the reel to prevent unwinding of the hose and damage to the nozzle.

6.5 Reel Hub Discharge—The reel hub discharge shall be angled to provide a smooth tangential contact of the hose with the reel drum as shown on Fig. 1 and Fig. 2, so that the hose will not kink at the discharge connection. The hub discharge fitting and adapter shall be in accordance with Fig. 2 and Fig. 3 for Types 1, 2, and 3, respectively. Reels shall be right- or left-hand operation and top or bottom wind, as specified. A right-hand, top-wind reel is defined as one that, when looking into the flanged adapter on the discharge fitting when it is at the top of the drum, has its inlet connection on the right-hand side. (Note that a top-wind, right-hand reel and a bottom-wind, left-hand reel are identical.) It shall be possible by turning the discharge fitting around, or by other simple means, to enable the hose to unreel from the bottom of the reel drum to either

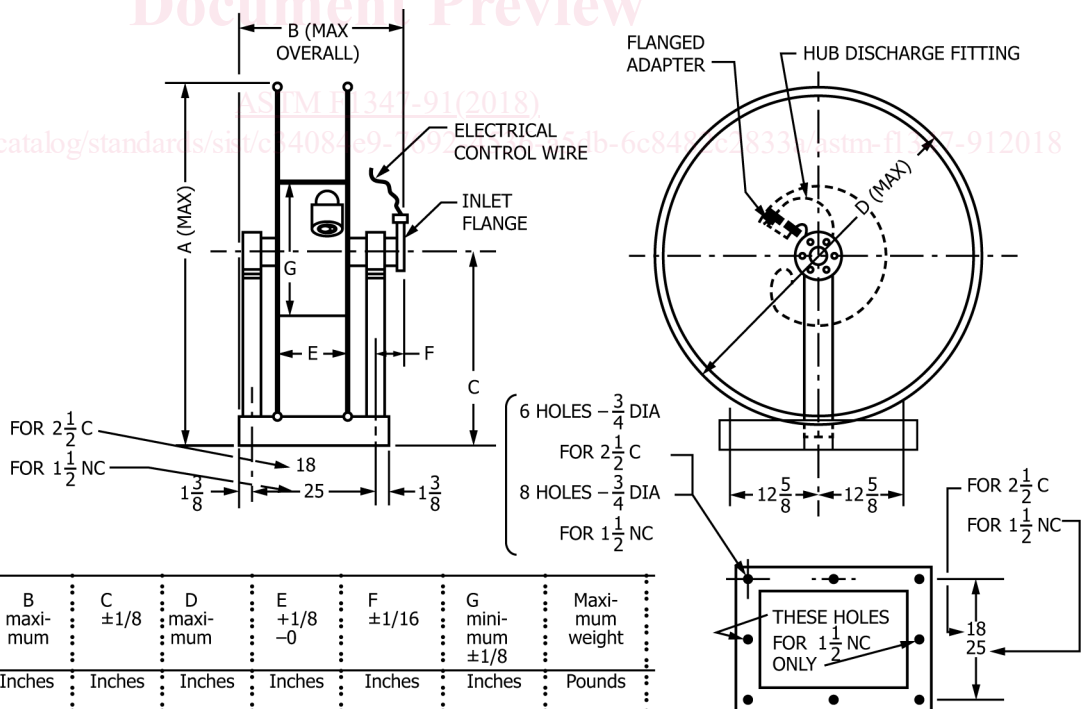

Hose reel type	A maximum	B maximum	C ±1/8	D maximum	E +1/8 -0	F ±1/16	G minimum ±1/8	Maximum weight
	Inches	Inches	Inches	Inches	Inches	Inches	Inches	Pounds
Type II and III-1-1/2 inches NC	55	31	30-1/2	48	18	3-3/4	30	185
Type II and III-2-1/2 inches C	55	23-1/8	30-1/2	48	11	3-3/4	20	175

FIG. 1 Hose Reel Dimensions

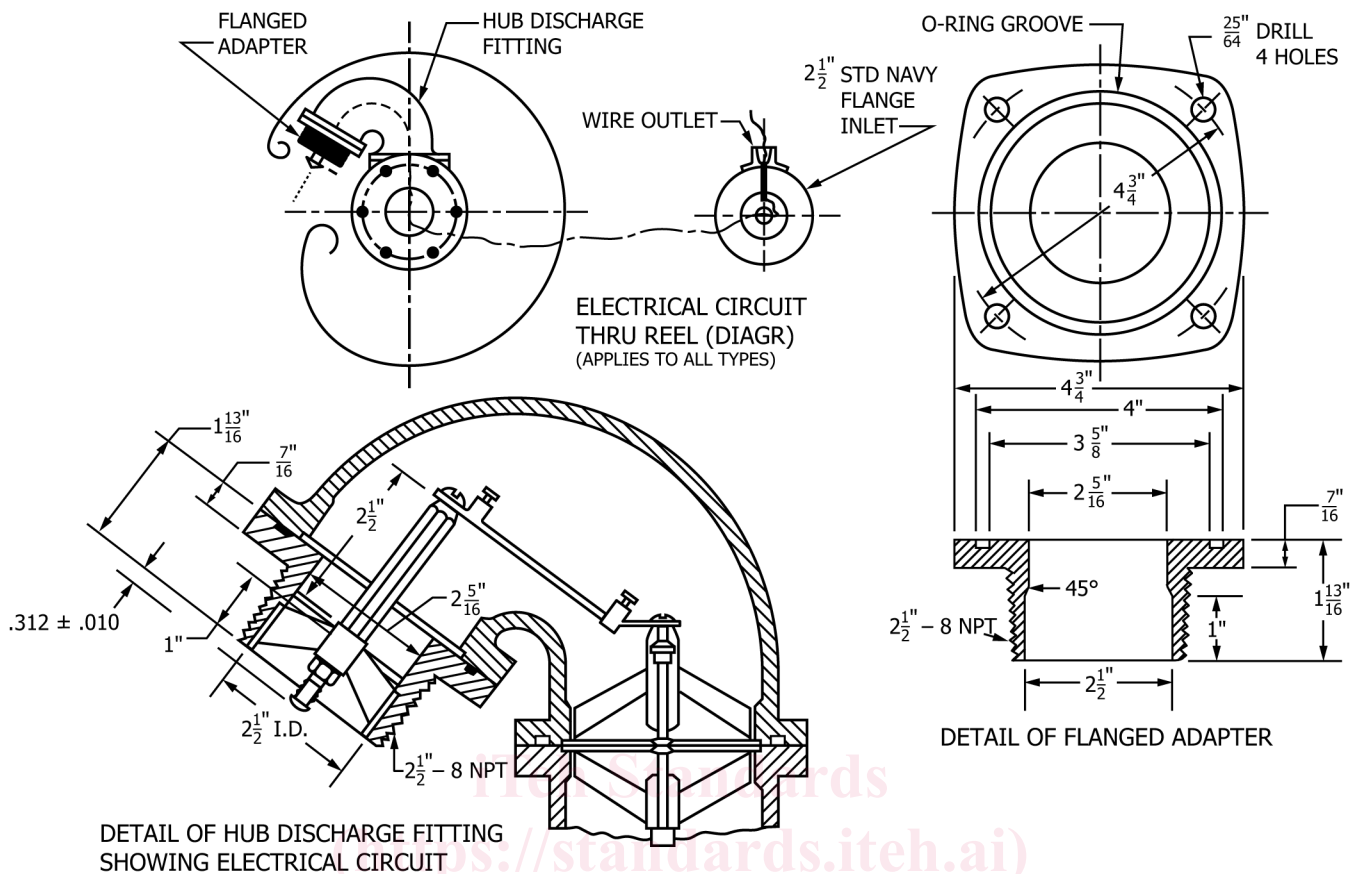

FIG. 2 Discharge Fitting and Adapter Details for Type 1 and 3, 2½-in. (65-mm) Collapsible Reels

side of the reel (that is, to make the reel either right hand or left hand) without rotating the reel drum.

6.6 *Aromatic Fuels Tight Rotating Joint*—The reel shall have an aromatic fuels tight rotating joint between reel inlet connection and the rotating hub on the reel drum. The rotating joint shall not bind under loading (shall be supported to prevent a bending load being applied), shall have provision for lubrication of moving parts, and shall be capable of easy disassembly for maintenance purposes. The rotating joint shall be tight under the pressure specified in 7.1.

6.7 *Inlet Connection*—The reel inlet connection shall be flanged, the flange being part of the rotating swivel joint. The flange thickness and bolt hole drilling shall be as specified in the contract or purchase order.

7. Performance Requirements

7.1 *Fluid Handling*—Reels shall be capable of passing 300 gal/min (0.0189 m³/s) of aviation fuel at a pressure of 150 psi (1.03 MPa) and shall withstand a static fuel pressure of 225 psi (1.55 MPa) without leakage or other signs of weakness. Restrictions and turbulence through the reel shall be kept to a minimum. For this purpose, the fluid path shall be of the 3½-in. (90-mm) size (including rotating swivel joint) and shall use long sweep elbows. The complete fluid-handling section of the reel (that is, from inlet flange to flanged adapter) shall be capable of being removed as a unit without disassembly of the drum or reel sides.

7.2 *Reel Hose Capacity*—Reels shall be capable of containing lengths of hose, as required, for Types 1, 2, 3, or 4. The hose used shall be either collapsible or noncollapsible as specified.

7.3 *Temperature*—The reels and the lubricant used shall be capable of satisfactory operation within the range of temperatures from -20 to +120°F (-29 to +49°C).

8. Dimensions, Mass, and Permissible Variations

8.1 The drum diameter shall not be less than the minimum bending diameter of the hose. The general outline and base mounting dimensions and mass shall be in accordance with Fig. 1.

9. Drawings

9.1 When specified in the contract or purchase order, detail assembly drawings shall be provided.

10. Workmanship, Finish, and Appearance

10.1 The reel and all parts shall be free of imperfections that may impair serviceability.

11. Sampling

11.1 *Lot*—For quality conformance, a lot shall consist of all reels of the same type, made at the same factory, of the same materials, of the same construction, and offered for delivery at the same time.