



## Standard Specification for Heat-Shrink Cable Entry Seals (Metric)<sup>1</sup>

This standard is issued under the fixed designation F1837M; the number immediately following the designation indicates the year of original adoption or, in the case of revision, the year of last revision. A number in parentheses indicates the year of last reapproval. A superscript epsilon ( $\epsilon$ ) indicates an editorial change since the last revision or reapproval.

### 1. Scope

1.1 This specification covers the general requirements for heat-shrink cable entry seals. Cable entry seals are intended for making electrical cable penetrations into connection boxes, bulkheads, or other enclosures. These devices are suitable for both thin wall enclosures up to 5 mm ( $\frac{3}{16}$  in.) thick and thick-wall enclosures of 5 mm to 19 mm ( $\frac{3}{16}$  in. to  $\frac{3}{4}$  in.) thick.

1.2 Cable entry seals shall have factory-applied adhesive that provides the seal to wire and cable jackets.

1.3 The values stated in SI units are to be regarded as standard. The values given in parentheses are mathematical conversions to inch-pound units that are provided for information only and are not considered standard.

1.4 *This standard does not purport to address all of the safety concerns, if any, associated with its use. It is the responsibility of the user of this standard to establish appropriate safety, health, and environmental practices and determine the applicability of regulatory limitations prior to use.*

1.5 *This international standard was developed in accordance with internationally recognized principles on standardization established in the Decision on Principles for the Development of International Standards, Guides and Recommendations issued by the World Trade Organization Technical Barriers to Trade (TBT) Committee.*

### 2. Referenced Documents

2.1 *ASTM Standards:*<sup>2</sup>

**D149** Test Method for Dielectric Breakdown Voltage and Dielectric Strength of Solid Electrical Insulating Materials at Commercial Power Frequencies

**D257** Test Methods for DC Resistance or Conductance of Insulating Materials

**D412** Test Methods for Vulcanized Rubber and Thermoplastic Elastomers—Tension

**D570** Test Method for Water Absorption of Plastics

**D635** Test Method for Rate of Burning and/or Extent and Time of Burning of Plastics in a Horizontal Position

**D747** Test Method for Apparent Bending Modulus of Plastics by Means of a Cantilever Beam

**D792** Test Methods for Density and Specific Gravity (Relative Density) of Plastics by Displacement

**D2240** Test Method for Rubber Property—Durometer Hardness

**D2671** Test Methods for Heat-Shrinkable Tubing for Electrical Use

**D2863** Test Method for Measuring the Minimum Oxygen Concentration to Support Candle-Like Combustion of Plastics (Oxygen Index)

**D3149** Specification for Crosslinked Polyolefin Heat-Shrinkable Tubing for Electrical Insulation

**D4066** Classification System for Nylon Injection and Extrusion Materials (PA)

**D4732** Specification for Cool-Application Filling Compounds for Telecommunications Wire and Cable

2.2 *ASME Standard:*<sup>3</sup>

**ASME B1.1** Unified Inch Screw Threads (UN and UNR Thread Form)

2.3 *NEMA Standard:*<sup>4</sup>

**NEMA 250** Enclosures for Electrical Equipment (1000 Volts Max)

2.4 *IEC Standard:*<sup>5</sup>

**IEC 68-2-6** Environmental Testing—Part 2: Tests—Test FC: Vibration (Sinusoidal), Sixth Edition

<sup>1</sup> This specification is under the jurisdiction of ASTM Committee F25 on Ships and Marine Technology and is the direct responsibility of Subcommittee F25.10 on Electrical.

Current edition approved Oct. 1, 2018. Published October 2018. Originally approved in 1997. Last previous edition approved in 2012 as F1837M – 97 (2012) <sup>$\epsilon$ 1</sup>. DOI: 10.1520/F1837M-97R18.

<sup>2</sup> For referenced ASTM standards, visit the ASTM website, www.astm.org, or contact ASTM Customer Service at service@astm.org. For *Annual Book of ASTM Standards* volume information, refer to the standard's Document Summary page on the ASTM website.

<sup>3</sup> Available from American Society of Mechanical Engineers (ASME), ASME International Headquarters, Two Park Ave., New York, NY 10016-5990, http://www.asme.org.

<sup>4</sup> Available from National Electrical Manufacturers Association (NEMA), 1300 N. 17th St., Suite 900, Arlington, VA 22209, http://www.nema.org.

<sup>5</sup> Available from International Electrotechnical Commission (IEC), 3, rue de Varembe, 1st floor, P.O. Box 131, CH-1211, Geneva 20, Switzerland, https://www.iec.ch.

3.1.2 *polyolefin, n*—a polymer made by the polymerization of hydrocarbon olefins or copolymerization olefins.

**4. Classification**

4.1 Heat-shrink cable entry seals shall be of the following types:

4.1.1 *Type I*, standard cable entry seals for thin-wall enclosures shall consist of the three part assembly; a rigid plastic nut, O-ring, and heat-shrinkable molded area.

4.1.1.1 *Type I-1*, molded area configured with one opening for a single wire or cable entry.

4.1.1.2 *Type I-2*, molded area configured with two equal size openings to seal two wires or cables.

4.1.1.3 *Type I-3*, molded area configured with three equal size openings to seal three wires or cables.

4.1.1.4 *Type I-4*, molded area configured with four equal size openings to seal four wires or cables.

4.1.1.5 *Type I-5*, molded area configured with six equal size openings to seal six wires or cables.

4.1.1.6 *Type I-6*, molded area configured with eight equal size openings to seal eight wires or cables.

4.1.2 *Type II*, cable entry seal for threaded hole applications shall consist of a one-part assembly that combines a tapered national pipe thread (NPT) in rigid plastic with heat-shrinkable molded area.

4.1.2.1 *Type II-1*, molded area configured with one opening for a single wire or cable entry.

4.1.2.2 *Type II-2*, molded area configured with two equal size openings to seal two wires or cables.

4.1.2.3 *Type II-3*, molded area configured with three equal size openings to seal three wires or cables.

4.1.2.4 *Type II-4*, molded area configured with four equal size openings to seal four wires or cables.

4.1.3 *Type III*, right angle cable entry seal for thin-wall enclosure shall consist of a three part assembly; a rigid plastic nut, O-ring, and heat-shrinkable molded area.

4.1.4 *Type IV*, right angle cable entry seal for threaded hole application shall consist of a one-part assembly that combines a tapered national pipe thread (NPT) in rigid plastic with a heat-shrinkable molded area.

**5. Ordering Information**

5.1 Orders for cable entry seals under this specification shall include the following:

5.1.1 Part Number (see Figs. 1-6).

5.1.2 Quantity (per each part).

**6. Materials and Manufacture**

6.1 The rigid plastic parts shall be made from polyamide (nylon), or polyester material, or both. The material shall be Group 1, Class 8, Grade 1 as specified in Specification D4066.

6.1.1 Threads shall be unified form UN 2A or 2B or taper pipe thread (NPT) as specified in ASME B1.1.

6.2 The heat-shrinkable tubing shall be of a crosslinked polyolefin in accordance with Type III of Specification D3149.

6.3 The adhesive shall be general purpose high-bond-strength adhesive sealant that provides stain relief and environmental sealing of heat-shrink tubing to cable jackets.

6.4 O-rings shall be made of a material conforming to Type II of Specification D4732.

6.5 The polyolefin heat-shrinkable tubing shall meet requirements of Test Methods D2671.

**7. Other Requirements**

7.1 *Dimensional Requirements*—Cable-entry seals shall conform to the dimensional requirements of Tables 1-6. Type I cable-entry seals are presented in Fig. 1 and Fig. 2. Type II cable-entry seals are presented in Fig. 3 and Fig. 4. Right-angle cable-entry seals (Types III and IV) are presented in Fig. 5 and Fig. 6.

7.2 *Performance Requirements:*

7.2.1 *Vibration Resistance*—When cable-entry seals are tested as specified in 9.1, there shall be no evidence of cracking or loosening of parts.

7.2.2 *Ruggedness*—When cable-entry seals are subjected to a mechanical abuse test as specified in 9.2, there shall be no cracking, breaking, distortion, or damage to the sample.

7.2.3 *Effectiveness of Seal*—When cable-entry seals are tested as specified in 9.3, there shall be no evidence of leakage through or around the cable entry seals.

**8. Workmanship, Finish, and Appearance**

8.1 Cable-entry seals shall be free from warp, cracks, chipped edges, or surfaces, blisters, uneven surfaces, scratches, dents, and flow lines. They shall be free from fins, burrs, and unsightly finish caused by chipping, filling, or grinding without subsequent buffing or polishing. All molded parts shall be cleaned thoroughly of annealing mediums.

**9. Test Methods**

9.1 Conformance testing of a random sample may be requested by the purchaser in order to verify that selected

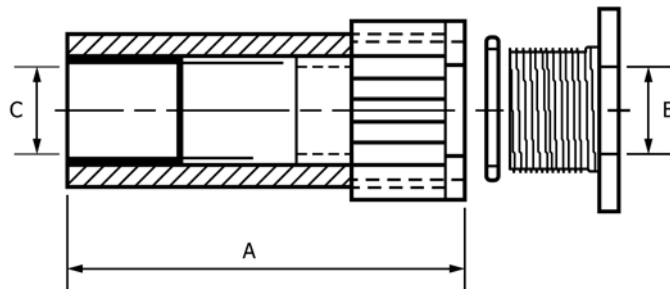

FIG. 1 Type I—Single-Legged Standard Cable Entry Seals

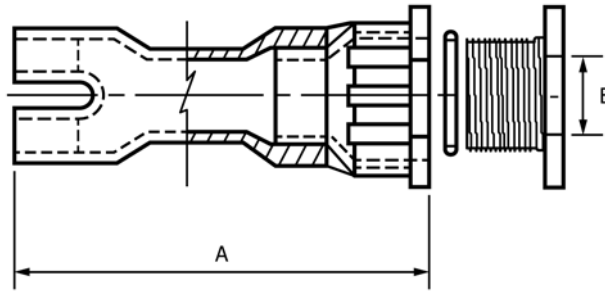

FIG. 2 Type I-Multi-Legged Standard Cable Entry Seals

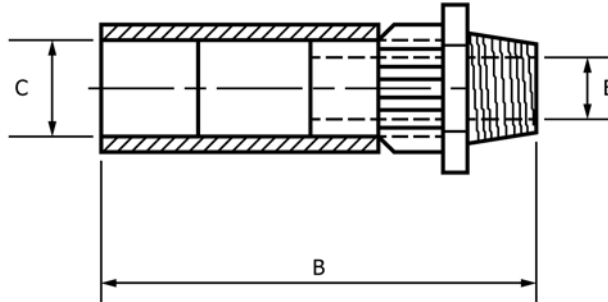

FIG. 3 Type II-Single-Legged Threaded Cable Entry Seals

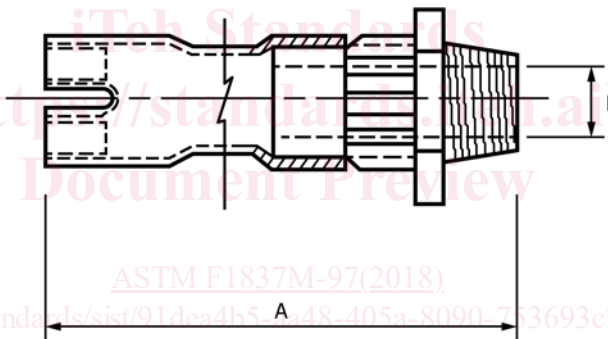

FIG. 4 Type II-Multi-Legged Threaded Cable Entry Seals

performance characteristics specified herein have been incorporated in the cable-entry seal design and maintained in production.

9.1.1 *Vibration*—The cable-entry seals shall be subjected to vibration testing as specified in IEC 68-2-6. The following details shall apply:

9.1.1.1 The cable-entry seals shall be complete with O-rings and 1 to 2-m (3 to 6-ft) lengths of cable of appropriate size.

9.1.1.2 The free end of the cables shall be secured to prevent excessive cable whipping action during test.

9.1.1.3 Tests are to be carried out in three perpendicular planes.

9.1.1.4 Duration of the test for no resonance condition shall be 90 min at 30 Hz. Duration at each resonance frequency at which  $Q > 2$  is recorded. It is recommended as guidance that  $Q$  does not exceed 5.

9.1.1.5 Test range shall be  $2 \pm 0.3$  Hz to 13.2 Hz—amplitude  $\pm 1$  mm; 13.2 Hz to 100 Hz—acceleration  $\pm 7$  g.

9.1.1.6 Nonconformance to the requirements of 7.2.1 shall be cause for rejection.

#### 9.2 Mechanical Abuse Test:

9.2.1 A mechanical abuse test shall be conducted on the sample cable-entry seal assembled on the end of a 2-m (6-ft) length of electrical cable of appropriate size.

9.2.2 The cable-entry seal shall be allowed to swing on a radius, while suspended by the electrical cable, from a vertical surface and strike against a vertical flat steel plate on that surface. The vertical distance through which the cable entry seal is allowed to fall shall be 1.5 m (5 ft), and the number of impacts shall be ten.

9.2.3 The cable-entry seal shall be disassembled and examined. Nonconformance to the requirements of 7.2.2 shall be cause for rejection.

9.3 *Level of Effectiveness*—A complete cable-entry seal with O-ring installed and assembled properly and shrunk to a cable

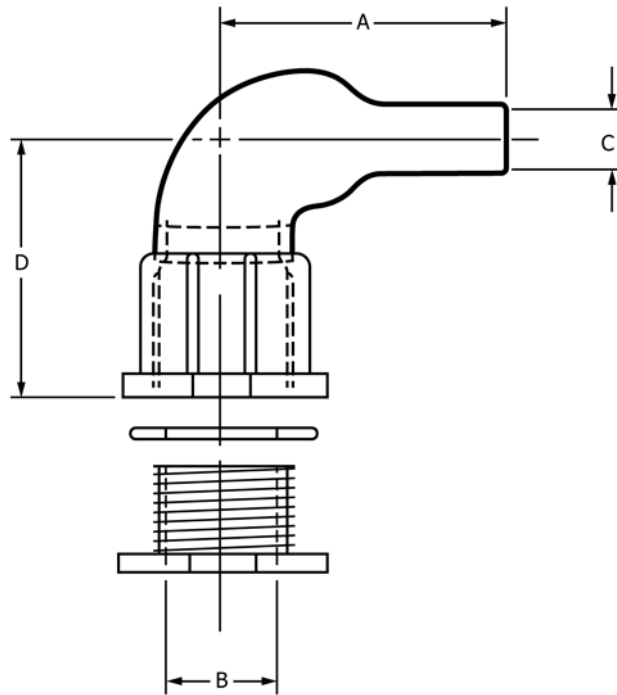

FIG. 5 Type III-Right-Angle Cable Entry Seals

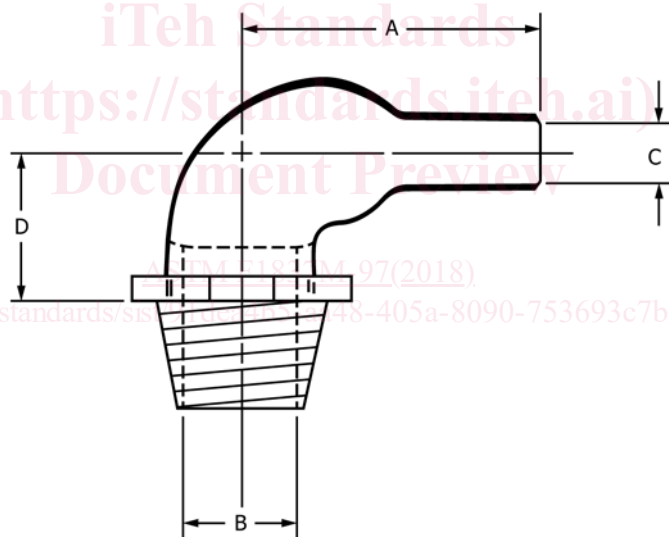

FIG. 6 Type IV-Right-Angle Cable Entry Seals

or with a plug installed shall conform to the performance requirements of NEMA 250. The NEMA enclosure type designation (4, 4X, 6, 6P) shall establish the appropriate environmental capability required of the installed cable-entry seal.

9.3.1 Nonconformance to the requirements of 7.2.3 shall be cause for rejection.

## 10. Inspection

10.1 *Visual and Dimensional Examination*—Samples shall be examined visually to verify that the materials, design, construction, physical dimensions, marking, and workmanship are as specified in the applicable requirements.

## 11. Certification

11.1 *Material Certification*—Material certification shall be required from the manufacturers of the plastic material and shirk-tubing to ensure the materials were manufactured, sampled, tested, and inspected in accordance with Specifications D4066 and D3149. Material identity traceable to this certification shall be maintained throughout the manufacturing process.

11.2 When specified in the purchase order or contract, the purchaser shall be furnished certification that samples representing each lot have been either tested or inspected as directed in this specification and the requirements have been met. When