



Designation: C687 – 18

Standard Practice for Determination of Thermal Resistance of Loose-Fill Building Insulation¹

This standard is issued under the fixed designation C687; the number immediately following the designation indicates the year of original adoption or, in the case of revision, the year of last revision. A number in parentheses indicates the year of last reapproval. A superscript epsilon (ϵ) indicates an editorial change since the last revision or reapproval.

1. Scope

1.1 This practice presents a laboratory guide to determine the thermal resistance of loose-fill building insulations at mean temperatures between -20 and 55°C (-4 to 131°F).

1.2 This practice applies to a wide variety of loose-fill thermal insulation products including but not limited to fibrous glass, rock/slag wool, or cellulosic fiber materials; granular types including vermiculite and perlite; pelletized products; and any other insulation material installed pneumatically or poured in place. It does not apply to products that change their character after installation either by chemical reaction or the application of binders or adhesives, nor does it consider the effects of structures, containments, facings, or air films.

1.3 Since this practice is designed for reproducible product comparison, it measures the thermal resistance of an insulation material which has been preconditioned to a relatively dry state. Consideration of changes of thermal performance of a hygroscopic insulation by sorption of water is beyond the scope of this practice.

1.4 The sample preparation techniques outlined in this practice do not cover the characterization of loose-fill materials intended for enclosed applications. For those applications, a separate sample preparation technique that simulates the installed condition will be required. However, even for those applications, some other aspects of this practice are applicable.

1.5 The values stated in SI units are to be regarded as the standard. The values given in parentheses are for information only.

1.6 *This standard does not purport to address all of the safety concerns, if any, associated with its use. It is the responsibility of the user of this standard to establish appropriate safety, health, and environmental practices and determine the applicability of regulatory limitations prior to use.*

1.7 *This international standard was developed in accordance with internationally recognized principles on standard-*

¹ This practice is under the jurisdiction of ASTM Committee C16 on Thermal Insulation and is the direct responsibility of Subcommittee C16.30 on Thermal Measurement.

Current edition approved Sept. 1, 2018. Published October 2018. Originally approved in 1971. Last previous edition approved in 2017 as C687 – 17. DOI: 10.1520/C0687-18.

ization established in the Decision on Principles for the Development of International Standards, Guides and Recommendations issued by the World Trade Organization Technical Barriers to Trade (TBT) Committee.

2. Referenced Documents

2.1 *ASTM Standards:*²

C167 Test Methods for Thickness and Density of Blanket or Batt Thermal Insulations

C168 Terminology Relating to Thermal Insulation

C177 Test Method for Steady-State Heat Flux Measurements and Thermal Transmission Properties by Means of the Guarded-Hot-Plate Apparatus

C518 Test Method for Steady-State Thermal Transmission Properties by Means of the Heat Flow Meter Apparatus

C653 Guide for Determination of the Thermal Resistance of Low-Density Blanket-Type Mineral Fiber Insulation

C739 Specification for Cellulosic Fiber Loose-Fill Thermal Insulation

C1045 Practice for Calculating Thermal Transmission Properties Under Steady-State Conditions

C1114 Test Method for Steady-State Thermal Transmission Properties by Means of the Thin-Heater Apparatus

C1363 Test Method for Thermal Performance of Building Materials and Envelope Assemblies by Means of a Hot Box Apparatus

C1373 Practice for Determination of Thermal Resistance of Attic Insulation Systems Under Simulated Winter Conditions

3. Terminology

3.1 Unless otherwise stated, the terms and definitions found in Terminology C168 are applicable herein.

4. Significance and Use

4.1 The thermal resistance, R , of an insulation is used to describe its thermal performance.

² For referenced ASTM standards, visit the ASTM website, www.astm.org, or contact ASTM Customer Service at service@astm.org. For *Annual Book of ASTM Standards* volume information, refer to the standard's Document Summary page on the ASTM website.

4.2 The thermal resistance of an insulation is related to the density and thickness of the insulation. It is desirable to obtain test data on thermal resistances at thicknesses and densities related to the end uses of the product.

4.3 In normal use, the thickness of these products range from less than 100 mm (4 in.) to greater than 500 mm (20 in.). Installed densities depend upon the product type, the installed thickness, the installation equipment used, the installation techniques, and the geometry of the insulated space.

4.4 Loose-fill insulations provide coverage information using densities selected by manufacturers to represent the product settled densities. Generally, it is necessary to know the product thermal performance at a representative density. Some coverage charts utilize multiple densities to show that greater thickness installations usually result in higher installed densities. The use of multiple densities can be detected from the coverage chart by calculating the density for several different thermal resistance levels. (The density for a given thermal resistance can be calculated from the coverage chart by dividing the minimum mass per unit area by the minimum thickness.) If the calculated densities are significantly different at different thermal resistances, the multiple density strategy has been used.

4.5 When applicable specifications or codes do not specify the nominal thermal resistance level to be used for comparison purposes, a recommended practice is to use the R_{si} (metric) = $3.3 \text{ m}^2\text{K/W}$ ($R_{IP} = 19 \text{ [h ft}^2\text{F/Btu]}$) label density and thickness for that measurement.

4.6 If the density for test purposes is not available from the coverage chart, a test density shall be established by use of applicable specifications and codes or, if none apply, agreement between the requesting body and the testing organization.

4.7 Generally, thin sections of these materials are not uniform. Thus, the test thickness must be greater than or equal to the product's representative thickness if the results are to be consistent and typical of use.

NOTE 1—The representative thickness is specific for each product and is determined by running a series of tests in which the density is held constant but the thickness is increased. The representative thickness is defined here as that thickness above which there is no more than a 2 % change in the resistivity of the product. The representative thickness is a function of product blown density. In general, as the density decreases, the representative thickness increases. Fortunately, most products are designed to be blown over a small range of densities. This limited range yields a range of representative thicknesses between 100 to 200 mm (4 to 8 in.) for most products. To simplify the process for this Practice, the representative thickness for the C687 tests shall be determined at the midpoint of the blown density range. Once this is accomplished, all thermal testing on this product is conducted at a thickness that is greater or equal to the representative thickness.

4.7.1 For this practice, the minimum test thickness shall be 100 mm (4 in.) or the representative thickness, whichever is larger. If the test is to represent an installation at a lesser thickness, the installed thickness shall be used.

4.8 Because of the high cost of construction and operation of large test equipment, it is impractical to test at the higher thicknesses at which products are used. For purposes of this practice, it is acceptable to estimate the thermal resistance at

any thickness from the thermal resistivity obtained from tests on the product at the minimum test thickness (see 4.7.1) and at the density expected for the proposed thickness.

4.9 In principle, any of the standard methods for the determination of thermal resistance are suitable for loose-fill products. These include Test Methods C177, C518, C1114, and C1363. Of these test methods, the heat flow meter apparatus, Test Method C518, is preferred.

4.10 The thermal resistance of low-density insulations depend upon the direction of heat flow. Unless otherwise specified, tests shall be performed for the maximum heat flow condition, that is, a horizontal specimen with heat flow-up.

4.11 Specimens shall be prepared in a manner consistent with the intended installation procedure. Products for pneumatic installation shall be pneumatically applied (blown), and products for pour-in-place installation shall be poured into specimen frames.

4.12 Loosefill insulation installed in attic applications will have heat flow up during the winter. At winter design conditions in many areas, the winter design temperature difference will cause convective heat transfer to occur within some loose-fill insulations. The procedure outlined in Practice C687 is not applicable to that measurement unless a Test Method C1363 test apparatus is used to reproduce the correct boundary conditions. To determine how seasonal differences can affect product performance, use Practice C1373. Practice C1373 measures the expected winter thermal performance of loose-fill insulation under simulated winter design temperature conditions and provides specimen requirements necessary for that determination.

5. Apparatus

5.1 Thermal test apparatus used for this practice shall meet these requirements.

5.1.1 *Conformance to Standards*—The apparatus shall conform to all requirements of the ASTM thermal test method used.

5.1.2 *Size and Error*—The apparatus shall be capable of testing specimens up to at least 150-mm (6-in.) thickness with an estimated error not greater than 1 % attributed to thickness/guard dimensions. (Parametric studies using a mathematical model of the proposed apparatus will give insight to this evaluation. For example see Table 1 in the 1976 revision of Test Method C518.³)

NOTE 2—Thermal test apparatus in use for this practice have overall plate dimensions of 457 to 1220 mm (18 to 48 in.) square with metering areas 152 to 457 mm (6 to 18 in.) square. Other sizes are acceptable if proper consideration of the size-thickness restrictions as outlined in the test method are observed in their design. (See Practice C1045 for additional discussion.)

5.1.3 *Temperature*—As a minimum, the apparatus shall be capable of testing at a mean temperature of 23.9°C (75°F) with a temperature difference of 20 to 28°C (36 to 50°F). The

³ See Table 1, "Maximum Spacing Between Warm and Cold Plates of Heat Flowmeter Apparatus," of Test Method C518 – 76 published in 1985 *Annual Book of ASTM Standards*, Vol 04.06.

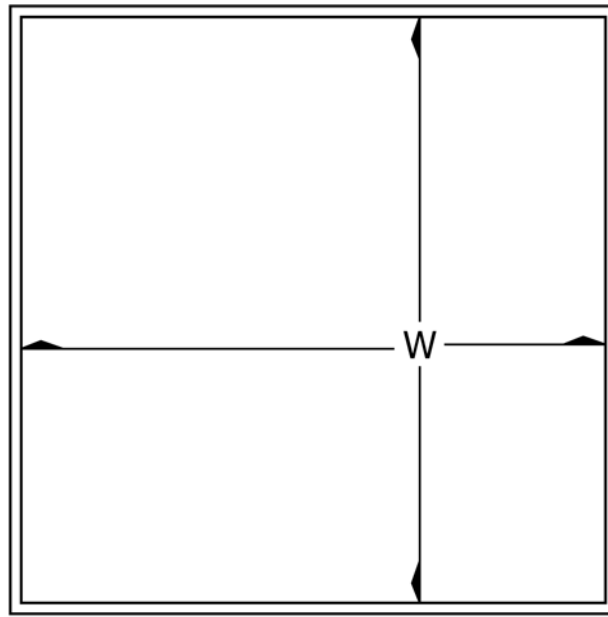

NOTE 1—Dimensions to match thermal test apparatus.

FIG. 1 Rigid Test Frame

ASTM C687-18

equipment shall be calibrated at the same temperatures as the test conditions. Some existing test apparatus have been designed to provide measurements over a range of mean temperatures from -20 to 55°C (-4 to 131°F) and for a wider range of temperature differences.

5.1.4 *Humidity*—The absolute humidity within the test apparatus shall be maintained low enough to prevent condensation within the specimen or on the cold plate(s). A maximum 9°C (48°F) dew point is consistent with the recommended material conditioning levels.

5.1.5 *Orientation and Direction of Heat Flow*—The thermal test apparatus shall be capable of testing horizontal specimens with heat flow-up. This orientation represents the most adverse heat flow condition for testing between two solid boundaries.

5.1.6 *Thermal Test Specimen Frame*—The test frame shall be sized to match the test apparatus and shall be made of materials having low thermal conductivity (<0.12 W/m K) and minimum thickness. A thin, thermally insignificant, screen or membrane is stretched across the bottom to support the material. Frames have fixed rigid sides or fold-down, collapsible, or compressible sides (see Fig. 1 and Fig. 2).

5.2 *Specimen Preparation Equipment:*

5.2.1 *Blowing Machine*—A blowing apparatus is required when pneumatically applied specimens are to be tested.

Choose the combination of hopper, blower, and hose size and length that is representative of common use for the application of the material to be tested. The following machine specifications have been developed for use with mineral wool and cellulosic materials.

5.2.1.1 *Mineral Fiber Insulations:*

(1) *Blowing Machine*—A commercial blowing machine with a design capacity for delivering the subject material at a rate between 4 and 15 kg (9 to 33 lb)/min.

(2) *Blowing Hose*—The machine shall utilize 46 m (150 ft) of typical 75 to 100 mm (3 to 4 in.) diameter flexible, internally corrugated blowing hose. At least 30 m (100 ft) of the hose shall be elevated between 3 and 6 m (10 and 20 ft) above the outlet of the blowing machine to simulate a typical installation configuration. The hose shall have no more than eight 90° bends and all bends shall be greater than 1.2-m (4-ft) radius. Before each sample preparation session, examine the hose for material remaining from previous blows. Dislodge any remaining material by mechanically agitating the hose when the machine is running. Repeat as necessary to maintain a clean hose for each specimen.

NOTE 3—In case of dispute, for mineral fiber insulations a 75 mm (3 in.) hose shall be used to prepare the specimens.

5.2.1.2 *Cellulosic Insulations:*

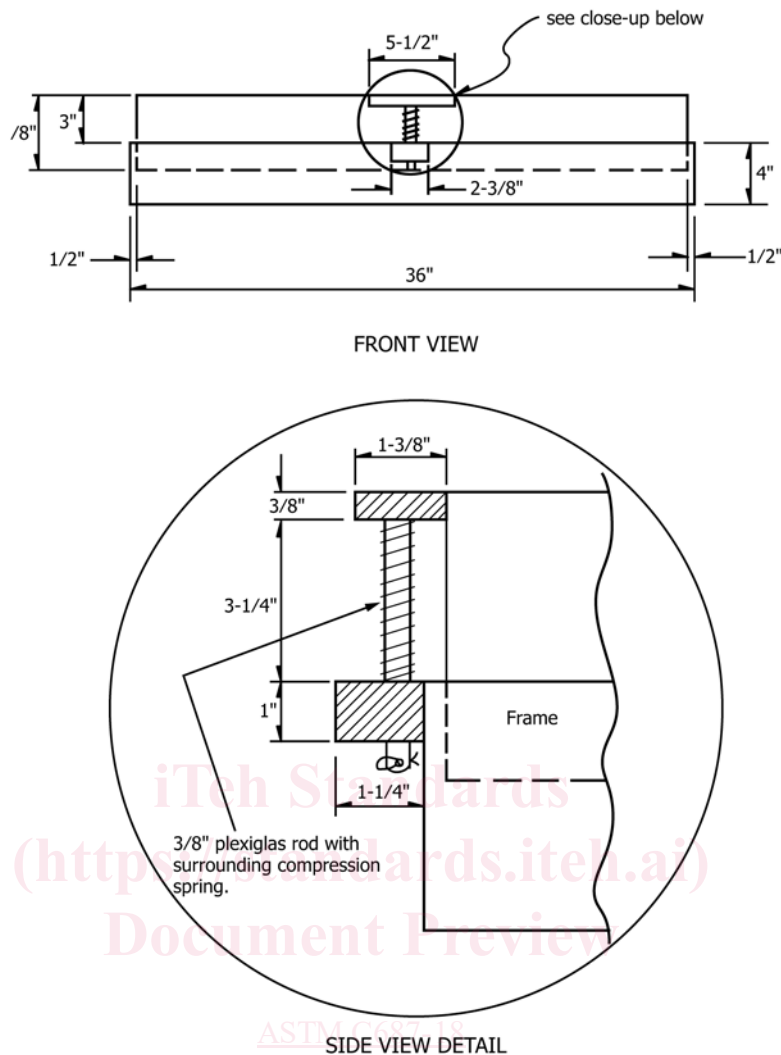

FIG. 2 Collapsible Test Frame (an Example)

(1) *Blowing Machine*—Use commercial blowing equipment designed for cellulosic material, that is, hopper, blower, and 30 m (100 ft) of typical 50 to 75 mm (2 to 3 in.) diameter hose.

(2) *Settled Density Catch Containers*—Containers shall be sized to match the test frames and shall be made of plywood or similar materials. A thin sheet of plywood attached across the bottom supports the insulation. Frames shall have fixed sides.

NOTE 4—In case of dispute, for cellulosic insulations a 51 mm (2 in.) hose shall be used to prepare the specimens

5.2.2 *Test Area Specimen Cutter*—A means for isolating the material within the metering area is required for the density determination. The isolated region shall have an area and shape identical to the metering area. Fig. 3 provides an example of a die cutter used for this purpose. The use of a compression plate to compress an area larger than the metering area, prior to metering area material removal is recommended. The compression plate shall extend at least 75 mm (3 in.) beyond the metering area boundary.

5.2.3 *Weighing Devices*—A device is required to weigh the test area material after the thermal test is complete. This device

shall determine the test area weight to within 0.5 %. A second device is required during sample preparation and conditioning to determine the sample plus frame weight. This device shall determine the combined weight to within 0.5 %.

5.2.4 *Conditioning Room*—An enclosure held at near constant temperature and humidity is required to stabilize the materials or products prior to testing. The conditions are generally given in product specifications or in other appropriate documents. In the absence of specific directions, conditioning shall be carried out in an atmosphere of $23 \pm 2^\circ\text{C}$ ($75 \pm 4^\circ\text{F}$) and a relative humidity not greater than 45 % (see 5.1.4).

5.2.5 *Specimen Support Sheet*—A stiff cardboard or equivalent sheet to be used to support the specimen during preparation, conditioning, and transport.

5.2.6 *Specimen Preparation Room*—A semi-enclosed area where the test material is blown into the specimen frame is required. This enclosure protects the blowing operation from wind or strong air currents. The room size shall not influence the blowing stream from the hose. Minimum room dimensions of 3 by 3 by 2.5 m (10 by 10 by 8 ft) are generally adequate for this purpose. Experience has shown that, to obtain uniform

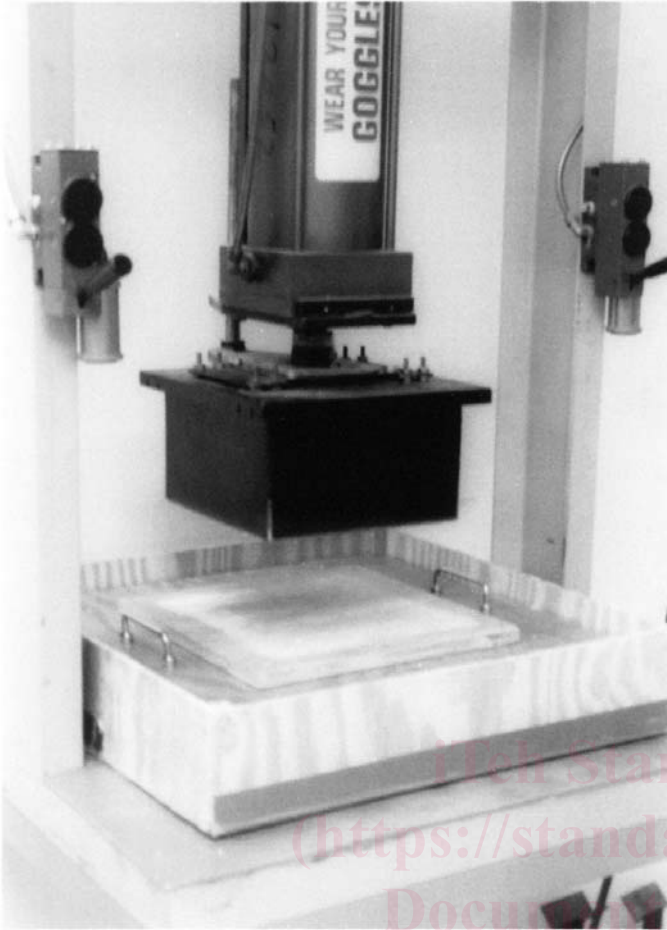

Note 1—Use of a pressure plate to compress a loose-fill specimen prior to cutting the metering area.

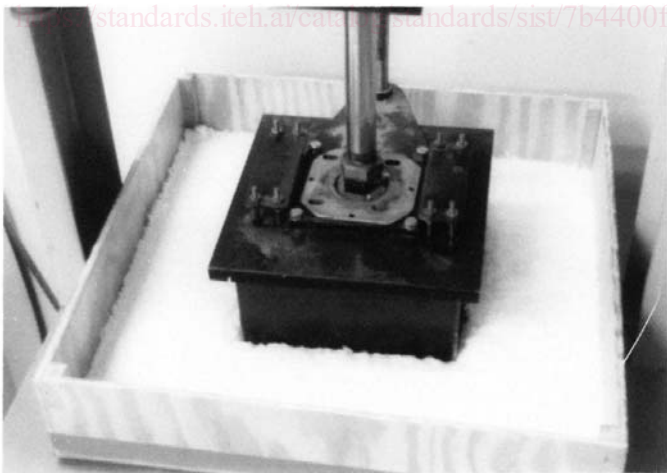

Note 2—Use of a hydraulic die cutter to cut the metering area. Note the compressed specimen after using the pressure plate.

FIG. 3 Test Area Cutter

specimens, it is necessary to blow an area greater than the dimensions of the specimen frame. The recommended area to be covered is at least 2.5 times the minimum test frame dimension.

6. Sampling

6.1 Sampling plans given in the material specifications, regulations, or other appropriate documents shall be followed when applicable. In the absence of such directions, material from at least two randomly chosen packages shall be combined in equal portions (weight) and placed in the blowing machine so as to combine materials as uniformly as practicable. Alternatively, multiple tests are performed where each specimen is made from a single package.

6.2 The insulation material shall be preconditioned at laboratory conditions (see 5.2.4) prior to the specimen blowing, if necessary, to remove excess moisture added during the manufacturing process. Preconditioning of materials not only ensures controlled blowing conditions but reduces the time required to condition the prepared specimen prior to thermal testing. For cellulosic materials, the preconditioning guideline is defined in Specification C739.

7. Specimen Preparation

7.1 Pneumatic Application—General Materials:

7.1.1 The procedure described in this section is intended for products which are normally installed pneumatically which do not exhibit settling under normal installed conditions. Use 7.2 for pneumatically installed products where the specimen preparation is modified to accommodate a correction for settling after installation.

NOTE 5—For commonly available loose-fill insulations, state and federal energy codes, ASTM material specifications, and the Federal Trade Commission have identified those materials that apply a correction for settling when determining thermal performance. It is beyond the scope of this practice to outline the procedures for this determination.

7.1.2 The specimen preparation room shall be clean and free of old insulation prior to the start of specimen preparation.

NOTE 6—Many factors influence the characteristics of the blown insulation. These include blowing rate, machine adjustments, the size and length of the hose, and the angle and dimensions of the hose outlet in relation to the test frame. Trained operators are required to duplicate field-installed conditioning. Some users of this method have constructed a support structure that holds the hose end at the proper orientation. This removes some of the operator dependency during the blowing operation.

NOTE 7—For ease of specimen preparation, the specimen shall be blown close to the desired test density. Operators have the option to establish a target weight of insulation required to fill the test frame as a control during the specimen preparation process. By placing the specimen frame and support sheet on a scale in the specimen preparation room while blowing occurs, it is possible to fill the container with the mass of the insulation targeted for the test. Another option is to eliminate these extra steps. The reported test density, however, is obtained from the metering area density measurement conducted after the thermal test.

7.1.3 If the specimen is to be blown to a predetermined density, calculate the target weight of insulation required to fill the test frame to the target thickness and density. If the intent is to test the material at whatever density is blown, then this calculation is not required.

7.1.4 Assemble the blowing machine, hose, and hose length combination as appropriate for the material being prepared (see recommendations in 5.2.1.1).

7.1.5 Set the blowing machine adjustments and select the feed rates in accordance with the insulation manufacturer's recommendations. If the insulation manufacturer does not

provide this information, consult the machine manufacturer for recommended settings. Record the machine settings used.

7.1.6 Place at least two packages (see 6.1) of the insulation material into the blowing machine hopper. If the hopper is too small to hold two packages of material, fill the hopper to capacity with equal portions of material from two packages.

7.1.7 Place the thermal specimen holder on the specimen support sheet in the center of the specimen preparation area (see Note 7).

7.1.8 Turn on the blowing machine with the hose outlet directed away from the test specimen frame. Do not blow the thermal test specimen until a steady flow of insulation material has been achieved.

7.1.9 Once steady flow is achieved, (approximately 30 to 45 s), direct the hose outlet toward the test specimen frame. The hose outlet shall be horizontal and at a height above the bottom of the test specimen frame of no less than 0.9 m and no greater than 1.2 m (3 to 4 ft). This height is measured from the centerline of the hose opening.

7.1.10 The end of the loose-fill trajectory falls beyond the test specimen frame at the start of the blow. The operator shall slowly step back, allowing the end of the trajectory to fall into the specimen frame. While continuing to back up, the operator slowly changes the direction of the hose approximately $\pm 45^\circ$ in a horizontal plane to uniformly fill the test specimen frame. The operator continues to make passes back and forth until the specimen frame is filled to approximately one half of the target thickness.

7.1.11 When the test specimen frame is approximately one half full, point the hose away from the test frame and stop the blowing machine. Remove all excess insulation from around the test frame, being careful not to disturb the insulation inside. Carefully rotate the test frame and support sheet 180° from their original position. Do not jar the frame or cause any unnecessary settling of the insulation. During handling of the blown specimen, keep the support sheet firmly against the bottom of the specimen frame.

NOTE 8—For some insulation materials, it is not necessary to rotate the specimen frame during blowing in order to prepare a uniform specimen. However, in case of dispute, the specimen preparation procedure listed, herein, shall be followed.

7.1.12 Restart the blowing machine, establish flow as in 7.1.8, and continue to fill the test specimen frame.

7.1.13 Continue blowing the material into the test frame until it is uniformly full and there is a slight excess above the target test thickness. Do not exceed 20 % excess thickness while blowing. For specimen preparation controlled by weight, the control must be a maximum of 110 % of the target weight in addition to the thickness limit stated in 7.1.13.

NOTE 9—If the intent is to test at a specific density and the specimen exceeds the upper mass limit without reaching the target thickness or exceeds the upper thickness limit without meeting the target mass, a new specimen must be prepared.

NOTE 10—Care shall be observed when handling or moving the filled specimen frame so as not to disturb the test specimen any more than is absolutely necessary. Any vibration or impact changes the pack structure of the blown sample and changes its thermal properties.

7.1.14 Remove the surrounding excess material from the area of the test frame. Move the specimen frame and support sheet to a flat level table.

7.1.15 Remove excess material to reach a level thickness that is no greater than 115 % of target test thickness. Do not disturb the remaining material, preserving it in the as-blown condition.

7.1.16 Move the specimen frame and its accompanying support sheet to the specimen conditioning room.

7.1.17 Condition the specimen and frame for sufficient time to reach constant weight (less than 1.0 % weight change in 24 h).

7.2 *Pneumatic Application—Settled Density Method:*

7.2.1 This method is intended for pneumatically installed products where the specimen preparation is modified to accommodate a correction for settling after installation.

NOTE 11—Although this section is specific to cellulosic insulations, the principles outlined are used for other insulations requiring correction for settled density, providing that the appropriate blowing equipment and settling simulation method (see 7.2.13) is used. Reference shall be made to the appropriate material specification to make this determination.

7.2.2 Assemble the blowing machine, hose, and hose length combination as appropriate for the insulation material being prepared. (See recommendations in 5.2.1.2.)

7.2.3 With the blower turned off, turn on the agitator in the hopper and load just enough insulation to cover the agitator.

7.2.4 Allow the agitator to run until the material appears to be thoroughly broken apart.

7.2.5 Hold the hose so the outlet is horizontal and at a height above the test specimen frame of no less than 0.9 m and no greater than 1.2 m (3 to 4 ft). This height is measured from the centerline of the hose opening. Turn on the blower and adjust the air slide on the inlet side of the blower until excessive dust begins to appear. Back off air slightly and record the setting. During this process, manually add insulation to the hopper to keep the agitator in the hopper covered.

7.2.6 Turn off the equipment and clean the specimen preparation room.

7.2.7 Place the thermal test frame on top of the support sheet in the center of the specimen preparation room and rotate the assembly 45° so that the diagonal of the specimen is in line with the blowing direction. Position four additional catch containers around the four sides on the test frame so as to create an “x” pattern.

7.2.8 Turn on the agitator and add insulation to the hopper until the agitator is covered.

7.2.9 Position the hose end as in 7.2.5 and, using the same air settings for the blower, turn on the blower. Once uniform flow is established, begin filling the test boxes at the rear of the specimen preparation room as follows. The end of the loose-fill trajectory falls beyond the test specimen frame at the start of the blow. The operator shall slowly step back, allowing the end of the trajectory to fall into the specimen frame and catch containers. While continuing to back up, the operator slowly changes the direction of the hose approximately $\pm 45^\circ$ in a horizontal plane to uniformly fill the test specimen frame. The operator continues to make passes back and forth until the