



Designation: F38 – 18

Standard Test Methods for Creep Relaxation of a Gasket Material¹

This standard is issued under the fixed designation F38; the number immediately following the designation indicates the year of original adoption or, in the case of revision, the year of last revision. A number in parentheses indicates the year of last reapproval. A superscript epsilon (ϵ) indicates an editorial change since the last revision or reapproval.

This standard has been approved for use by agencies of the U.S. Department of Defense.

1. Scope

1.1 These test methods provide a means of measuring the amount of creep relaxation of a gasket material at a predetermined time after a compressive stress has been applied.

1.1.1 *Test Method A*—Creep relaxation measured by means of a calibrated strain gauge on a bolt.

1.1.2 *Test Method B*—Creep relaxation measured by means of a calibrated bolt with dial indicator.

1.2 The values stated in SI units are to be regarded as standard. The values given in parentheses are for information only.

1.3 *This standard does not purport to address all of the safety concerns, if any, associated with its use. It is the responsibility of the user of this standard to establish appropriate safety, health, and environmental practices and determine the applicability of regulatory limitations prior to use.*

1.4 *This international standard was developed in accordance with internationally recognized principles on standardization established in the Decision on Principles for the Development of International Standards, Guides and Recommendations issued by the World Trade Organization Technical Barriers to Trade (TBT) Committee.*

2. Referenced Documents

2.1 *ASTM Standards:*²

[A193/A193M Specification for Alloy-Steel and Stainless Steel Bolting for High Temperature or High Pressure Service and Other Special Purpose Applications](#)

[B637 Specification for Precipitation-Hardening and Cold Worked Nickel Alloy Bars, Forgings, and Forging Stock for Moderate or High Temperature Service](#)

[D3040 Practice for Preparing Precision Statements for Stan-](#)

[dards Related to Rubber and Rubber Testing \(Withdrawn 1987\)](#)³

[F104 Classification System for Nonmetallic Gasket Materials](#)

[F436/F436M Specification for Hardened Steel Washers Inch and Metric Dimensions](#)

2.2 *ASTM Adjuncts:*

Relaxometer, Method A (F38)⁴

Relaxometer, Method B (F38)⁵

3. Summary of Test Methods

3.1 In both test methods the specimen is subjected to a compressive stress between two platens, with the stress applied by a nut and bolt.

3.2 In Test Method A, normally run at room temperature, the stress is measured by a calibrated strain gauge on the bolt. In running the test, strain indicator readings are taken at intervals of time, beginning at the loading time, to the end of the test. The strain indicator readings are converted to percentages of the initial stress which are then plotted against the log of time in hours. The percentage of initial stress loss or relaxation can be read off the curve at any given time, within the limits of the total test time.

3.3 In Test Method B, run at room or elevated temperatures, the stress is determined by measuring the change in length of the calibrated bolt with a dial indicator. The bolt length is measured at the beginning of the test and at the end of the test; from this the percentage of relaxation is calculated.

4. Significance and Use

4.1 These test methods are designed to compare related materials under controlled conditions and their ability to maintain a given compressive stress as a function of time. A portion of the torque loss on the bolted flange is a result of

¹ These test methods are under the jurisdiction of ASTM Committee F03 on Gaskets and are the direct responsibility of Subcommittee F03.20 on Mechanical Test Methods.

Current edition approved Aug. 1, 2018. Published November 2018. Originally approved in 1962. Last previous edition approved in 2014 as F38 – 00 (2014). DOI: 10.1520/F0038-18.

² For referenced ASTM standards, visit the ASTM website, www.astm.org, or contact ASTM Customer Service at service@astm.org. For *Annual Book of ASTM Standards* volume information, refer to the standard's Document Summary page on the ASTM website.

³ The last approved version of this historical standard is referenced on www.astm.org.

⁴ A print of this apparatus is available at a nominal cost from ASTM International Headquarters. Order Adjunct No. [ADJF003801](#). Original adjunct produced in 1965.

⁵ Detailed working drawings of this apparatus are available from ASTM International Headquarters. Order Adjunct No. [ADJF003802](#). Original adjunct produced in 1965.

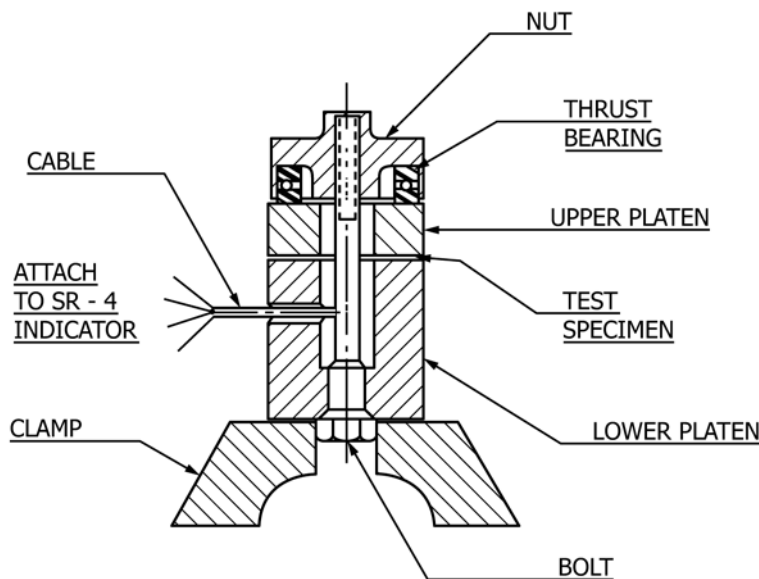

FIG. 1 Relaxometer, Test Method A

creep relaxation. Torque loss can also be caused by elongation of the bolts, distortion of the flanges, and vibration; therefore, the results obtained should be correlated with field results. These test methods may be used as a routine test when agreed upon between the consumer and the producer.

NOTE 1—Test Method B was developed using asbestos gasket materials and at issuance substantiating data were not available for other gasket materials.

5. Apparatus

5.1 Test Method A:

5.1.1 Strain Indicator:

5.1.2 Timer:

5.1.3 Relaxometer,⁴ composed of two platens, upper and lower; a bolt, with mounted strain gauge; and a thrust bearing as shown in Fig. 1.

5.1.4 Strain Gauges,⁶ 120 Ω resistance with a gauge factor of 2.0 ± 0.10 %. The gauges shall be mounted to indicate tensile strain and positioned to compensate for torque, temperature, and bending. The gauges shall be mounted on the small diameter of the bolt about 50.8 mm (2 in.) from the head. The bolt with mounted strain gauges must be calibrated.

5.2 Test Method B:

5.2.1 Relaxometer, Platen Assembly⁵ composed of two platens, specially drilled and calibrated bolt, washer and nut composed of Specification A193/A193M Grade B7 or Specification B637 Grade UNS N07718 or other alloys of construction that would satisfy the calibration procedure (see Annex) for the test temperature specified, as shown in Fig. 2.

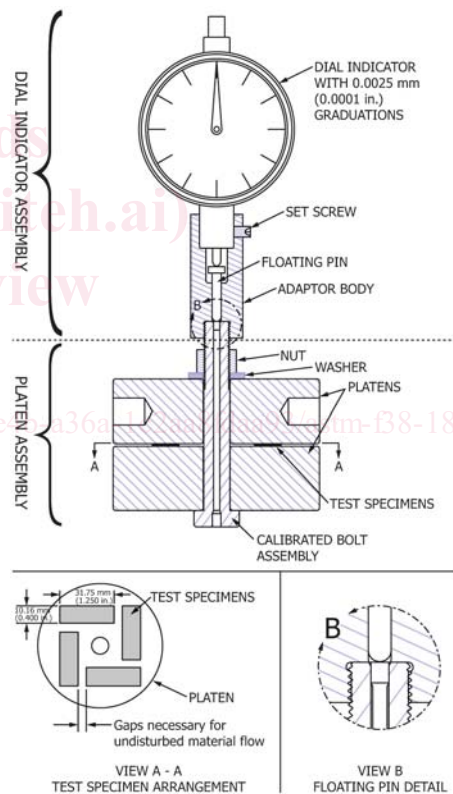

FIG. 2 Relaxometer, Platen Assembly and Dial Indicator Assembly, Test Method B

5.2.2 Dial Indicator Assembly, composed of an adaptor body, floating pin, set screw, and dial indicator, as shown in Fig. 2. Dial indicator should have graduations of 0.0025 mm (0.0001 in.) or smaller.

5.2.3 Box End Wrench—⁹/₁₆ in., Qty. 2.

⁶ The sole source of supply of strain gauges (Type AB-7) known to the committee at this time is Baldwin-Lima-Hamilton. If you are aware of alternative suppliers, please provide this information to ASTM International Headquarters. Your comments will receive careful consideration at a meeting of the responsible technical committee,¹ which you may attend.

6. Test Specimen

6.1 *Test Method A*—The sample size shall be 33.02 ± 0.05 mm (1.300 ± 0.002 in.) in inside diameter and 52.32 ± 0.05 mm (2.060 ± 0.002 in.) in outside diameter.

6.2 *Test Method B*:

6.2.1 Specimen size shall be 10.16 ± 0.381 mm (0.400 ± 0.015 in.) wide by 31.75 ± 0.381 mm (1.250 ± 0.015 in.) long. Four specimens are required per test.

6.2.2 An annular specimen with 1290-mm^2 (2.0-in.^2) surface area may also be used. A size of 15.62-mm (0.615-in.) inside diameter by 43.56-mm (1.715-in.) outside diameter is recommended.

6.2.3 For Type 4 Class 2 materials, specimen size shall be one continuous length of 152.4 mm (6.0 in.).

6.3 A minimum of three tests shall be conducted.

6.4 Nominal thickness of specimen shall be 0.8 mm (0.03 in.) unless otherwise agreed upon between the consumer and the producer. For Type 4 materials the nominal thickness of the specimen shall be no greater than 1.78 mm (0.07 in.).

7. Conditioning

7.1 Condition cut specimens in accordance with their classification as required in Classification **F104**.

8. Procedure

8.1 *Test Method A*:

8.1.1 Clean all surfaces, platens, and specimen free of wax, mold release, and oils. (Remove with *isooctane* or other suitable solvent.) Lubricate bolt threads.

8.1.2 Use an initial stress of 13.8 ± 0.3 MPa (2000 ± 50 psi) unless otherwise specified.

8.1.3 Conduct the test at 20 to 30°C (70 to 85°F) unless otherwise specified.

8.1.4 Disassemble the relaxometer and place the specimen between platens. The inside diameter of the specimen should be nearly concentric with the inside diameter of the platens. Screw on the nut and thrust bearing and tighten *very slightly*, by hand, or just enough to hold the specimen in place during subsequent handling. Mount the head of the bolt in a clamp.

8.1.5 Hook up and balance the strain indicator. Record the reading. Then set the reading on the strain indicator for the specified initial stress. (The micrometers that are added to the above reading will vary the stress and the strain gauge bolt calibration.)

8.1.6 Apply stress to the gasket by tightening the nut with a solid wrench until the strain indicator reaches a balance. A torque of approximately 30 N·m (22 lbf·ft) is required for a compressive force of 17.8 kN (4000 lbf). The stress should be applied at uniform rate such that at the end of 10 ± 2 s the specified stress is reached. This is called the “initial stress.”

8.1.7 Beginning at the time of “initial stress,” take strain indicator readings at intervals of 10 s, 1 min, 6 min, 30 min, 1 h, 5 h, 24 h, etc., or until the end of the test. (Check the zero of the strain indicator after the test.)

8.1.8 Convert the strain indicator readings of **8.1.7** to a percentage of “initial stress.” Then plot this percentage on semilog paper against the log of time in hours.

8.2 *Test Method B*:

8.2.1 Clean all surfaces and lightly lubricate the washer and bolt threads; graphite and molybdenum disulfide have been found to be acceptable lubricants.

8.2.2 Place rectangular specimens between the platens in accordance with **Fig. 2** and making sure they are no closer than 2 mm (0.078 in.) to the other pieces and the edge of the platens. If an annular specimen is used, center the specimen around the bolt hole between the platens. If a Type 4 Class 2 specimen is used, center the specimen around the bolt hole between the platens, being certain that the two ends overlap by a minimum of 6.35 mm (0.25 in.).

8.2.3 Place the washer in position and screw on the nut, finger tight.

8.2.4 Screw on the dial indicator assembly, finger tight, and set the dial indicator at the zero reading.

8.2.5 Apply stress to the specimens by tightening the nut with a wrench until the desired dial indicator reading is reached. Record the reading (D_0). Apply the stress in one continuous motion with a maximum loading time of 3 s. A bolt elongation of 0.1222 to 0.1270 mm (0.00481 to 0.00500 in.) is typical for a compressive force of 26.7 kN (6000 lbf). Remove the dial indicator assembly. (The calibration procedure is outlined in **Annex A1**.)

NOTE 2—When testing materials thicker than 0.8 mm (0.03 in.), the time to tighten the nut may be extended to 5 s maximum to allow for the longer arc required to apply the test load.

8.2.6 Place the specimen unit in a hot air-circulating oven for 22 h at $100 \pm 2^\circ\text{C}$ ($212 \pm 3.6^\circ\text{F}$), unless otherwise specified. The maximum test temperature for Specification **A193/A193M** Grade B7 shall not exceed 204.4°C (400°F) and the maximum test temperature for Specification **B637** Grade UNS N07718 shall not exceed 482.2°C (900°F).⁷

8.2.7 Remove from the oven and cool to room temperature.

8.2.8 Replace the dial indicator assembly, finger tight, and set the dial indicator at the zero reading. Loosen the nut, without disturbing the dial indicator assembly, and record the dial reading (D_p).

8.2.9 Calculate the percentage relaxation as follows:

$$\text{Relaxation, \%} = [(D_0 - D_p) / D_0] \times 100 \quad (1)$$

9. Report

9.1 Report the following information:

9.1.1 Identification and designation number of the material tested,

9.1.2 Test temperature,

9.1.3 Length of the test, in hours,

9.1.4 “Initial stress” used, and the specimen thickness,

9.1.5 Percentage stress loss for each specimen, and

9.1.6 Average of all the results recorded in **9.1.5**.

⁷ Some laboratories have found Alloy A-286 meets the calibration standard at temperatures up to 482.2°C (900°F). The user may specify any alloy of construction as long as the alloy meets the calibration standard for the desired test temperature.

TABLE 1 Precision of Creep Relaxation Test of Gasket Materials, Using Coefficient of Variation Method of Presenting Results

NOTE 1—

 S = standard deviation.

 $CV = \% \text{ coefficient of variation} = (S \times 100) / (\text{average})$.

 $LSD = \% \text{ least significant difference between two individual test results based on a 95 \% confidence level, } = 2 \sqrt{2} (CV)$.

NOTE 2—An annular specimen can be used in place of rectangular specimens for Type 1, Class 2; Type 5, Class 1; Type 7, Class 1; and Type 7, Class 2. An annular specimen cannot be used in place of rectangular specimens for Type 1, Class 1 because of the statistically significant difference in results.

Material Type and Class, Classification F104	Relaxation Values, %		Repeatability			Reproducibility		
	Range	Average	S	CV, %	LSD, %	S	CV, %	LSD, %
Type 1, Class 1	11.5–15.4	13.3	1.22	9.4	26.5	1.58	11.9	33.7
Type 1, Class 2	27.2–33.7	30.9	1.87	6.2	17.6	2.52	8.2	23.1
Type 5, Class 1	4.0–8.9	6.3	1.27	18.1	51.2	2.01	31.9	90.1
Type 7, Class 1	14.2–24.5	18.1	1.33	8.0	22.7	3.93	21.8	61.5
Type 7, Class 2	20.7–28.5	26.0	0.97	4.2	11.8	3.10	11.9	33.7

10. Precision and Bias⁸

10.1 These precision and bias statements have been prepared in accordance with Practice **D3040**. Please refer to this practice for terminology and other testing and statistical concept explanations.

10.2 Seven laboratories tested the following five gasket materials (Classification **F104** material designations) for creep relaxation: Type 1, Class 1; Type 1, Class 2; Type 5, Class 1; Type 7, Class 1; Type 7, Class 2. Test Method B, Type 1 conditioning was used by all laboratories. Rectangular test specimens were prepared from gasket sheets by cutting them with the long dimension in the machine direction. Tests were

conducted in accordance with Test Methods F38, Test Method B, with an initial stress of 20.68 MPa (3000 psi) applied on a 1290-mm² (2-in.²) sample area, total of 26.7-kN (6000-lb) compressive force. The tests were conducted for 22 h at 100°C (212°F). The tests were conducted in triplicate on each material using the A193 Grade B7 Fixture.

10.3 The precision results for the Specification **A193/A193M** Grade B7 Fixture are given in **Table 1**.

10.4 Additional F38 Round Robin test data regarding the evaluation of Specification **B637** UNS N07718 is provided in **Appendix X1**.

11. Keywords

11.1 creep relaxation; deflection; gasket material; platens; relaxometer; strain; stress; temperature; torque bolt; torque loss

⁸ Supporting data have been filed at ASTM International Headquarters and may be obtained by requesting Research Report RR:F03-1009.

ASTM F38-18

<https://standards.iteh.ai/catalog/standards/sist/57c7f661-6c4-4e4b-a36a-1c2aa8fdaa93/astm-f38-18>

ANNEX

(Mandatory Information)

A1. TEST METHOD B CREEP RELAXATION APPARATUS: BOLT CALIBRATION PROCEDURE

A1.1 Purpose

A1.1.1 To precondition (strain relieve) the bolts at elevated temperature prior to calibration.

A1.1.2 To calibrate the bolts after preconditioning, and on a periodic basis after use. Bolts used at temperatures greater than 205°C (401°F) should be recalibrated more often than bolts used at lower test temperatures.

A1.1.3 To ensure that the bolt is functioning properly.

A1.2 Apparatus

A1.2.1 *Relaxometer*, in accordance with **5.2.1**, modified so that each platen can accept a pair of steel dowel pins.

A1.2.2 *Dial Indicator Assembly*, in accordance with **5.2.2**.

A1.2.3 *Flat Washer*, Size $\frac{7}{16}$ in. as defined in Specification **F436/F436M**. Material should be Type I, 38-45 HRC (hardness), only to be used during calibration for spacing purposes.

A1.2.4 *Tensile Testing Machine*, capable of obtaining and recording a load of 26.7 kN (6000 lbf). The maximum allowable system error equals 0.5 % of the applied load.

A1.2.5 *Bolt Calibration Apparatus*, to connect the relaxometer to the tensile machine. See **Fig. A1.1**.

A1.3 Procedure

A1.3.1 If the bolts to be calibrated are new, they must be preconditioned using the following procedure. Assemble the relaxometer without gaskets, and install the dial indicator