



## Standard Test Method for Measuring Maximum Function Volume of the Primary Dirt Receptacle in a Vacuum Cleaner<sup>1</sup>

This standard is issued under the fixed designation F888; the number immediately following the designation indicates the year of original adoption or, in the case of revision, the year of last revision. A number in parentheses indicates the year of last reapproval. A superscript epsilon ( $\epsilon$ ) indicates an editorial change since the last revision or reapproval.

### 1. Scope

1.1 This test method covers household types of upright, canister, and combination vacuum cleaners.

1.2 This test method provides a measurement in dry quarts or litres of the maximum functional volume of the primary dirt receptacle when installed in the vacuum cleaner.

1.3 *This standard does not purport to address all of the safety concerns, if any, associated with its use. It is the responsibility of the user of this standard to establish appropriate safety, health, and environmental practices and determine the applicability of regulatory limitations prior to use.* For specific hazards statements see 7.2 and 8.5.

1.4 *This international standard was developed in accordance with internationally recognized principles on standardization established in the Decision on Principles for the Development of International Standards, Guides and Recommendations issued by the World Trade Organization Technical Barriers to Trade (TBT) Committee.*

### 2. Referenced Documents

2.1 SAE Standard:<sup>2</sup>

SAE J726b Air Cleaner Test Code

### 3. Significance and Use

3.1 This test method covers a procedure to determine the maximum functional volume of the primary dirt receptacle when installed in the vacuum cleaner.

3.2 This test method provides the maximum amount of test media that the primary dirt receptacle will hold and may be more than the volume obtained when filled to the manufacturer's recommended fill line.

### 4. Apparatus

4.1 *Voltmeter*, to measure input voltage to the cleaner, to provide measurements accurate to within  $\pm 1\%$ .

4.2 *Voltage Regulator System*, to control the input voltage to the vacuum cleaner. The regulator system shall be capable of maintaining the vacuum cleaners rated voltage of  $\pm 1\%$  and rated frequency  $\pm 1$  Hz having a wave form that is essentially sinusoidal with 3 % maximum harmonic distortion for the duration of the test.

4.3 *Temperature Measuring Equipment*, to provide measurements accurate to within  $\pm 1^\circ\text{F}$  ( $0.5^\circ\text{C}$ ).

4.4 *Humidity Measuring Equipment*, to provide measurements accurate to within  $\pm 2\%$  relative humidity.

4.5 *Adapter*, to be attached to the cleaning nozzle of upright cleaners for use in directing granulated cork into the nozzle. See Fig. 1.

4.6 *Volume Measuring Container*, to measure volume of granulated cork. This shall have a capacity of one dry quart. See Fig. 2. The container shall be made of transparent material to ensure no voids when filled with granulated cork. As an option, a 1-L container can be used.

4.7 *Weighing Scale*—The scale shall be accurate to 0.035 oz (1 g) and have a weighing capacity of at least 15 lb (6.82 kg).

<sup>1</sup> This test method is under the jurisdiction of ASTM Committee F11 on Vacuum Cleaners and is the direct responsibility of Subcommittee F11.23 on Filtration. Current edition approved Nov. 1, 2011/Oct. 1, 2018. Published March 2012/November 2018. Originally approved in 2004. Last previous edition approved in 2006/2011 as F888–06/F888–06 (2011). DOI: 10.1520/F0888-06R11-10.1520/F0888-06R18.

<sup>2</sup> Available from Society of Automotive Engineers (SAE), 400 Commonwealth Dr., Warrendale, PA 15096-0001.

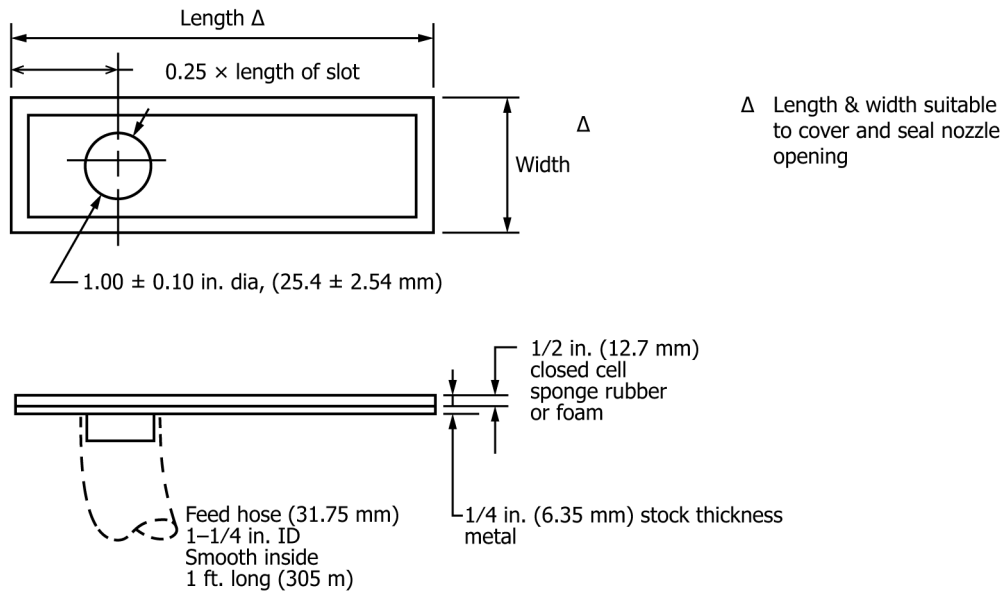

FIG. 1 Adapter Plate for Uprights

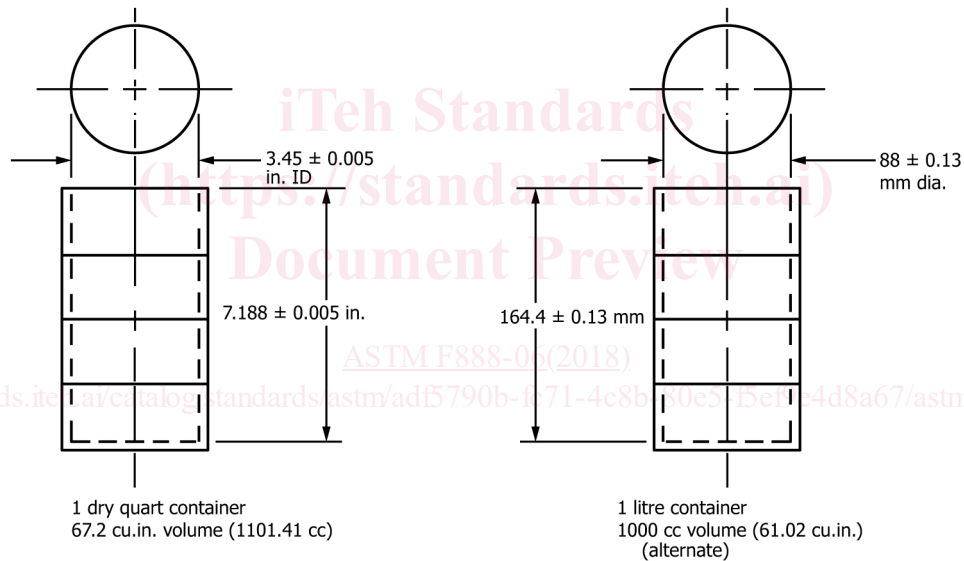

FIG. 2 Volume Measuring Container

## 5. Materials

5.1 *New Granulated Cork*—Premium Grade 2 mm to 4 mm size.<sup>3</sup>

5.2 *Coarse-Grade Air Cleaner Test Dust*, see Table 1. As an option, talc may be used. See Table 2.

## 6. Sampling

6.1 *Determination of Sample Size*—A sample of sufficient size of each model shall be tested until a 90 % confidence level is established within  $\pm 5$  % of the mean value. A minimum of three samples shall be tested. All samples shall be selected at random in accordance with good statistical practices.

6.2 *Determination of Maximum Functional Volume for Each Unit*—The maximum functional volume for each unit shall be an average of three runs with a spread meeting the repeatability statement in 9.2. (See Appendix X1 for example.)

<sup>3</sup> The sole source of supply of the test material known to the committee at this time is Jelinek Cork Corp., 4500 Witmer Industrial Estates, PMB 167, Niagara Falls, NY 14305-1386. If you are aware of alternative suppliers, please provide this information to ASTM International Headquarters. Your comments will receive careful consideration at a meeting of the responsible technical committee,<sup>1</sup> which you may attend.

**TABLE 1 Analysis of Coarse Grade Air Cleaner F11 Test Dust<sup>A</sup>**

Particle Size Distribution by Volume	
Size, $\mu\text{m}$	Coarse Grade (% less than)
5.5	13 $\pm$ 3
11	24 $\pm$ 3
22	37 $\pm$ 3
44	56 $\pm$ 3
88	84 $\pm$ 3
176	100

<sup>A</sup> The information in Table 1 is contained in "Air Cleaner Test Code," *SAE Technical Report J726b*.

**TABLE 2 Analysis of Unscented Commercial Grade Talcum**

Particle Size Distribution by Weight, %	
0.5 %	44 $\mu$
12.5 %	20–43.9 $\mu$
27.0 %	10–19.9 $\mu$
23.0 %	5–9.9 $\mu$
20.0 %	2–4.9 $\mu$
8.0 %	1–1.9 $\mu$
9.0 %	0.9 $\mu$

## 7. Conditioning

7.1 Maintain the test room at  $70 \pm 5^\circ\text{F}$  ( $21 \pm 3^\circ\text{C}$ ) and 45 to 55 % relative humidity.

7.2 Expose all components involved in the test to the controlled environment for at least 16 h prior to the start of the test. (**Warning**—Store sufficient 100 qt or 100-L increments of granulated cork in such a manner that when used they are in a state of constant mass/unit volume.)

## 8. Procedure

8.1 Establish density of granulated cork in grams per dry quarts or grams per litres as follows:

8.1.1 Weigh the empty container.

8.1.2 Withdraw 100 qt or 100 L from the bulk quantity.

8.1.3 From the quantity withdrawn in 8.1.2, fill the container with granulated cork by gently pouring the granulated cork through the funnel shown in Fig. 3.<sup>4</sup> Move the funnel around in a horizontal plane to ensure even filling of the container. Do not shake or disturb the container during this operation. Introduce the granulated cork at a uniform rate of 1 qt/min or 1 L/min  $\pm$  10 s.

8.1.4 Weigh the filled container.

8.1.5 Subtract the results of 8.1.1 from the results of 8.1.4 for the weight of 1 qt or 1 L of granulated cork.

8.1.6 Set the measured quantity of granulated cork aside.

8.1.7 Repeat 8.1.3 – 8.1.6 ten times. Calculate the mean weight.

8.1.8 Return the 10-qt or 10-L samples to the withdrawn quantity of 8.1.2.

8.1.9 If testing is completed in the same day by the same technician, use the mean result of 8.1.7 in subsequent calculations until the quantity withdrawn is depleted. Otherwise, recalculate the 10-qt mean.

8.1.10 When quantity withdrawn is depleted, select another 100-qt or 100-L sample in accordance with 8.1.2 – 8.1.9.

8.2 Prepare the test cleaner as follows:

8.2.1 Install new or clean primary and secondary filters.

8.2.2 Prepare the primary dirt receptacle prior to conducting the measurement test run.

8.2.2.1 For cleaners using disposable primary filters, use a new manufacturer's recommended bag, weigh the filter bag to the nearest 0.035 oz (1.0 g) and install in accordance with the manufacturer's recommended procedure. Repeat this process for each test. Perform the filter bag prior to installation to ensure full installation.

8.2.2.2 For cleaners using cloth filter bags or other types of nondisposable dirt receptacles, empty them in accordance with the manufacturer's instructions after each test run, and clean the receptacle until its weight is within 0.14 oz (4 g) of the previous weight.

8.3 Energize the vacuum cleaner for 5 min at its rated voltage  $\pm$  1 % and rated frequency  $\pm$  1 Hz. For vacuum cleaners with dual nameplate voltage ratings, conduct the testing at the highest voltage.

<sup>4</sup> A 10 1/2-in. diameter utility funnel, Stock No. 78026, has been found suitable for this purpose. The sole source of supply of the apparatus known to the committee at this time is U.S. Plastic Corp., 1390 Newbrecht Rd., Lima, OH 45801. If you are aware of alternative suppliers, please provide this information to ASTM International Headquarters. Your comments will receive careful consideration at a meeting of the responsible technical committee,<sup>1</sup> which you may attend.

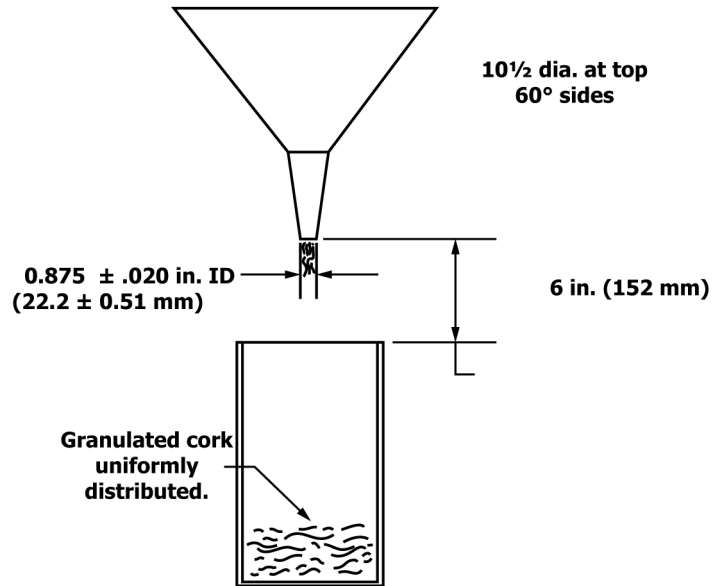

FIG. 3 Filling Container for Average Weight

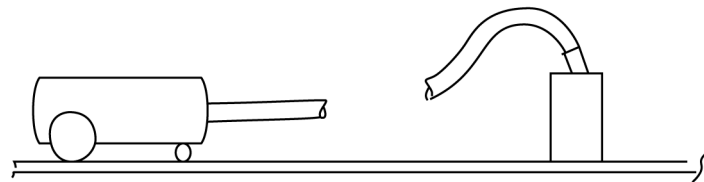
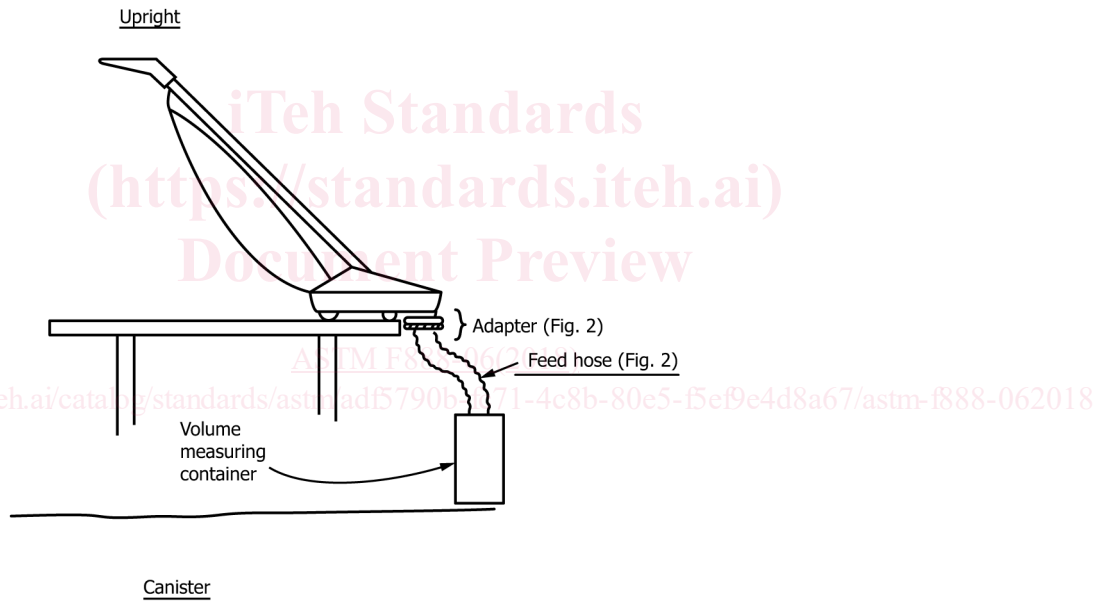

FIG. 4 Test Set-up

8.3.1 Place an upright cleaner so that the moving bristles clear the supporting surface and no loose dirt is picked up.

8.3.2 For a straight air canister or combination cleaner, operate with hose only, unrestricted and positioned such that no loose dirt is picked up.

8.4 If the test vacuum cleaner contains a disposable or reusable primary inflatable filter bag, precondition the primary filter bag as follows:

8.4.1 Measure and calculate the total primary filtering area excluding seams, joints, treated seal area, mounting means, and multiple thickness of media. Measure multiple thicknesses that are intended for a specific filtering purpose as a single ply. Open, measure, and take a mean measurement from three bags from the same sample as the bags to be tested.

8.4.2 Prepare 0.0023 oz of test dust per square inch of primary filter area (0.010 g/cm<sup>2</sup>) (see [Table 1](#) and [Table 2](#)). Feed the test dust at the rate of 0.7 ± 0.07 oz/min (20 ± 2 g/min) into the intake port to inflate the bag.

8.4.3 If the test vacuum cleaner does not contain a disposable or reusable primary inflatable filter bag, the primary filter does not need to be preconditioned as in [8.4.1](#) and [8.4.2](#).

8.5 Testing has shown that the test media, granulated cork, can be reused a maximum of ten times without affecting the maximum functional volume measurement. (**Warning**—If granulated cork is reused, the density in grams per dry quarts or grams per litres must be reestablished (see [8.1](#) – [8.1.10](#)).

8.6 Introduce the granulated cork at a uniform rate of 1 qt/min or 1 L/min ± 10 s into the vacuum cleaner in accordance with [8.6.1](#), [8.6.2](#), or [8.6.3](#).

8.6.1 For an upright cleaner, without attached hose or attachment port, feed the granulated cork through the adapter on the nozzle. Use only adapter shown in [Fig. 1](#) or equivalent. The handle of the upright cleaner should be placed in the position specified in the instruction book for above-the-floor cleaning.

8.6.2 For an upright cleaner with attached hose or attachment port, feed the granulated cork through hose attached or the hose provided for the attachment port. The handle of the upright cleaner should be placed in the position specified in the instruction book for above-the-floor cleaning.

8.6.3 For canister and combination cleaners, feed the granulated cork through the hose accompanying the model being tested. The hose and cleaner must be placed in such a manner that their position will allow a uniform pickup from the container (see [Fig. 4](#)).

8.7 De-energize the cleaner after it will accept no more granulated cork.

8.7.1 For bagless or hard dirt receptacle cleaners, de-energize the cleaner after the granulated cork reaches the receptacle “full line.” If the receptacle has no “full line,” continue the test until the cleaner will accept no more granulated cork. Do not include any granulated cork remaining outside the dirt receptacle in the maximum functional volume measurement.

8.8 Carefully remove the primary dirt receptacle containing the collected granulated cork. Do not include any granulated cork remaining outside the primary dirt receptacle system, including the delivery tube, in the maximum functional volume measurement.

8.9 Weigh the primary dirt receptacle and collected granulated cork.

8.10 Calculate the weight of granulated cork collected in the primary dirt receptacle by subtracting the dirt receptacle and test dust weight (if added) as described in [8.2.2](#) and [8.4.2](#) from the full dirt receptacle weight (see [8.9](#)). Calculate the maximum functional volume by dividing the total weight of collected granulated cork by the average weight of granulated cork per quart or litre in accordance with [8.1](#).

8.11 Record the maximum functional volume in dry quarts or litres to the nearest tenth.

8.12 The maximum functional volume for a single test is the number of quarts or litres of granulated cork collected by the primary dirt receptacle. The maximum functional volume of a given vacuum cleaner is the mean value of three tests meeting the repeatability statements specified in [9.2](#). (See [Appendix X1](#) for example.)

## 9. Precision and Bias

9.1 *Precision*—For bagged vacuums, these statements are based on an interlaboratory test involving twelve laboratories and four units. The range of maximum functional volume of the units was from 0.90 to 9.4 dry quarts.<sup>5</sup> For bagless upright vacuums only, these statements are based on an interlaboratory test involving twelve laboratories and four units. The range of maximum functional volume of the units was from 1.12 to 2.23 dry quarts.<sup>5,6</sup> No data is currently available to make statements concerning the precision of other types of bagless vacuums.

9.2 *Repeatability (single-operator-laboratory)*—The expected standard deviation of repeatability of the measured results within a laboratory,  $S_r$ , has been found to be the respective values listed in [Table 3](#).

9.2.1 The 95 % repeatability limit within a laboratory,  $r$ , has been found to be the respective values listed in [Table 1](#), where  $r = 2.8(S_r)$ .

9.2.2 With 95 % confidence, it can be stated that within a laboratory, a set of measured results derived from testing a unit should be considered suspect if the difference between any two of the three values is greater than the respective values of the repeatability limit,  $r$ , listed in [Table 3](#).

<sup>5</sup> Supporting data have been filed at ASTM International Headquarters and may be obtained by requesting Research Report RR:F11-1004.

<sup>6</sup> Supporting data have been filed at ASTM International Headquarters and may be obtained by requesting Research Report RR:F11-1016.

**TABLE 3 Repeatability and Reproducibility**

Type Cleaner	Standard Deviation of Repeatability, $S_r$	Repeatability, $r$	Standard Deviation of Reproducibility, $S_R$	Reproducibility Limit, $R$
Bagless Upright Vacuum	0.07	0.21	0.19	0.52
Bagged Vacuum	0.10	0.28	0.47	1.32

9.3 *Reproducibility (multi-laboratory)*—The expected standard deviation of reproducibility of the average of a set of measured results between multiple laboratories,  $S_R$ , has been found to be the respective values listed in **Table 3**.

9.3.1 The 95 % reproducibility limit within a laboratory,  $R$ , has been found to be the respective values listed in **Table 3**, where  $R = 2.8(S_R)$ .

9.3.2 With 95 % confidence, it can be stated that the average of the measured results from a set of three test runs performed in one laboratory, as compared to a second laboratory, should be considered suspect if the difference between those two values is greater than the respective values of the reproducibility limit,  $R$ , listed in **Table 3**.

9.3.3 If the absolute value of the difference between the average of the measured results from the two laboratories is not equal to or less than the respective reproducibility limit listed in **Table 3**, the set of results from both laboratories shall be considered suspect.

9.4 *Bias*—No justifiable statement can be made on the bias of this test method. The true values of the properties cannot be established by acceptable referee methods.

## 10. Keywords

10.1 filtration; maximum functional volume; vacuum cleaner

## APPENDIX

### (Nonmandatory Information)

#### X1. DETERMINATION OF 90% CONFIDENCE INTERVAL

X1.1 The most common and ordinarily the best single estimate of the population mean  $\mu$  is simply the arithmetic mean of the measurements. When a sample is taken from a population, the sample average will seldom be exactly the same as the population average; however, it is hoped to be fairly close so that the statement of confidence interval will bracket the true mean.

<https://standards.iteh.ai/catalog/standards/astm/adf5790b-fc71-4c8b-80e5-f5ef9e4d8a67/astm-f888-062018>

X1.2 The following procedure gives an interval which is expected to bracket  $\mu$ , the true mean, 100(1 -  $\alpha$ ) % of the time. This provides a 100(1 -  $\alpha$ ) % confidence level.  $\alpha$  is the chance of being wrong, therefore, 1 -  $\alpha$  is the probability of being correct.

X1.2.1 Choose the desired confidence level, 1 -  $\alpha$ .

X1.2.2 Compute Mean ( $\bar{X}$ ):

$$\bar{X} = \frac{1}{n} \sum_{i=1}^n X_i \quad (\text{X1.1})$$

$$\text{Standard Deviation, } s = \sqrt{\frac{n \sum X_i^2 - (\sum X_i)^2}{n(n-1)}}$$

where:

$n$  = number of units.

X1.2.3 Compute the upper limit ( $X_U$ ) and the lower limit ( $X_L$ ):

$$X_U = \bar{X} + ts/\sqrt{n} \quad (\text{X1.2})$$

$$X_L = \bar{X} - ts/\sqrt{n}$$