



Designation: C 633 – 01

## Standard Test Method for Adhesion or Cohesion Strength of Thermal Spray Coatings<sup>1</sup>

This standard is issued under the fixed designation C 633; the number immediately following the designation indicates the year of original adoption or, in the case of revision, the year of last revision. A number in parentheses indicates the year of last approval. A superscript epsilon ( $\epsilon$ ) indicates an editorial change since the last revision or reapproval.

*This standard has been approved for use by agencies of the Department of Defense.*

### 1. Scope

1.1 This test method covers the determination of the degree of adhesion (bonding strength) of a coating to a substrate or the cohesion strength of the coating in a tension normal to the surface. The test consists of coating one face of a substrate fixture, bonding this coating to the face of a loading fixture, and subjecting this assembly of coating and fixtures to a tensile load normal to the plane of the coating. It is adapted particularly for testing coatings applied by thermal spray, which is defined to include the combustion flame, plasma arc, two-wire arc, high-velocity oxygen fuel, and detonation processes for spraying feedstock, which may be in the form of, wire, rod, or powder.

NOTE 1—Thermal spray coating materials include ceramics, such as metal oxides or carbides, and metals. In some cases, a coating is formed of different spray materials, such as an oxide layer sprayed onto a sprayed metal-bonding layer. The substrate generally is a metal, but may be a ceramic, such as an oxide or graphite.

1.2 Usually this test method is performed at ambient temperature. Higher temperature testing is restricted by the need for a suitable adhesive bonding agent. For certain fundamental investigations, it is suggested that very low (cryogenic) temperature be used.

1.3 This test method is limited to testing thermal spray coatings that can be applied in thickness greater than 0.015 in. (0.38 mm). The limitation is imposed because an adhesive bonding agent is used in the test. Those bonding agents established so far for this method tend to penetrate thermal spray coatings and may invalidate results unless the coatings are thick enough to prevent penetration through the coating. Further development may establish that thin layers of certain types of especially dense coatings may be tested satisfactorily. Alternatively, new adhesive bonding agents that would allow reduction of the minimum thickness limitation may become available.

1.4 *This standard does not purport to address all of the safety concerns, if any, associated with its use. It is the*

*responsibility of the user of this standard to establish appropriate safety and health limitations prior to use.*

### 2. Referenced Documents

2.1 *ASTM Standards:*

E 4 Practices for Force Verification of Testing Machines<sup>2</sup>

### 3. Significance and Use

3.1 This test method is recommended for quality control, acceptance testing; or it may help to develop or qualify a thermal spray operator's equipment and procedure or to aid in developing thermal spray coatings with improved adhesion and integrity.

3.2 This test method is useful for comparing adhesion or cohesion strengths of coatings of similar types of thermal spray materials. The test should not be considered to provide an intrinsic value for direct use in making calculations, such as to determine if a coating will withstand specific environmental stresses. Because of residual stresses in thermal spray coatings, actual strength depends upon the shape of the particular coated part. Also, in use, a coating may be stressed in a more complex manner than is practical for a standard test.

### 4. Apparatus

4.1 A tension testing machine shall conform to the requirements of Practices E 4. The loads used in determining the adhesion or tensile strength shall be within the loading range of the testing machine, as defined in Practices E 4. Permissible variation shall be less than 1.0 %. It shall be possible to apply increasing tensile load at a constant rate of cross-head travel between 0.030 in./min (0.013 mm/s) and 0.050 in./min (0.021 mm/s). The machine shall include a load-indicating device that registers the maximum load applied before rupture occurs.

4.2 Self-aligning devices, for applying the tensile load to the assembly of the coating and fixtures, shall not permit eccentric load or bending moment to the specimen. Self-alignment is often provided by the manufacturer as an integral part of the testing machine. An alternative, satisfactory apparatus is shown in Fig. 1, which also shows methods of connecting the self-aligning apparatus to an assembled test specimen.

<sup>1</sup> This test method is under the jurisdiction of ASTM Committee B08 on Metallic and Inorganic Coatings and is the direct responsibility of Subcommittee B08.12 on Materials for Porcelain Enamel and Ceramic-Metal Systems.

Current edition approved March 10, 2001. Published July 2001. Originally published as C 633 – 69. Last previous edition C 633 – 79 (1999).

<sup>2</sup> *Annual Book of ASTM Standards*, Vol 03.01.

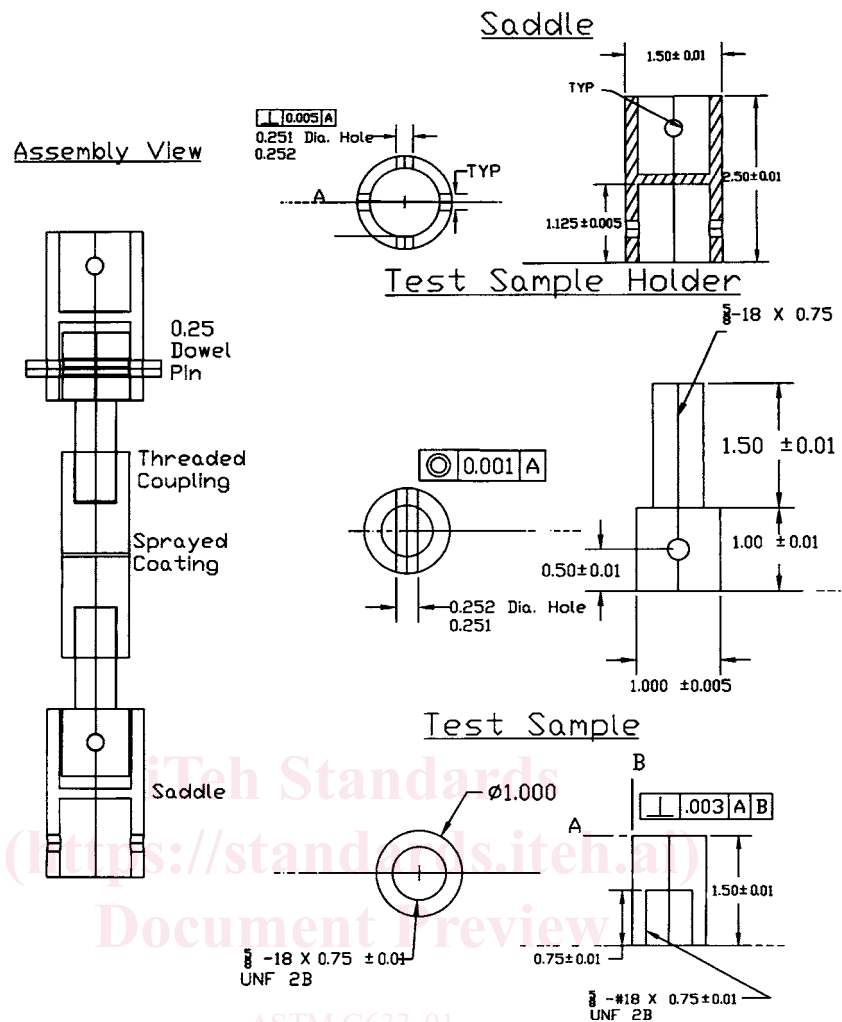

FIG. 1 Self-Aligning Device

## 5. Material

5.1 *Adhesive Bonding Agent*—A suitable adhesive bonding agent shall be agreed between the purchaser and manufacturer of the coating and shall meet the following requirements.<sup>3</sup>

5.1.1 The bonding agent shall be capable of bonding the coating to the loading fixture with a tensile strength that is at least as great as the minimum required adhesion and cohesion strength of the coating.

5.1.2 The bonding agent shall be sufficiently viscous not to penetrate through a 0.015-in. (0.38-mm) thickness of the coating. Certain commercial resins that cure or harden at room temperature by means of a curing agent have been proven satisfactory. If any other bonding agent is to be used, it shall first be compared with a proven bonding agent using this test method with the desired thermal spray coating.

NOTE 2—Thermal spray coatings may have an inherent porosity. Excessive penetration of the adhesive bonding agent into this porosity may affect the results determined by this test method. Unless proved satisfactory by comparison testing, any agent requiring elevated temperature for curing should be avoided because viscosity may decrease at high temperature, allowing penetration.

NOTE 3—When liquid epoxy bonding agents are used, there should be a procedure in place to ensure relatively consistent thickness on every sample.

5.1.3 The adhesion strength of the bonding agent shall be determined each time this test method is performed. This shall be done by using the bonding agent to attach a loading fixture to a second loading fixture, in accordance with 6.5, except that the coated substrate fixture of 6.5 is replaced with the second loading fixture.

NOTE 4—One reason for testing the bonding agent each time is to detect improper preparation of the agent if it is a two-part mix. Another reason is that adhesion strength generally decreases with age of the unused agent. If strength is lower than required, more adhesive bonding agent shall be prepared and tested, or the agent shall be discarded and replaced.

<sup>3</sup> A list of satisfactory bonding agents is provided in the annex which follows this standard.

6. Test Specimens

6.1 *Substrate and Loading Fixtures*—Each test specimen is an assembly comprising a substrate fixture, to which the coating is applied, and a loading fixture. The substrate and loading fixtures shall each be circular, solid cylinders of no less than 1.5 in. in length, or as agreed upon by the manufacturer and customer. A suggested detail for either fixture is shown in Fig. 2. One end of each fixture shall be adapted for attachment to the self-aligning loading devices of the tension testing machine. Both ends of each fixture shall have faces parallel to each other and normal to the loading axis. The facing diameters shall be not less than 0.9 in. (23 mm), nor more than 1.0 in. (25 mm). The diameters of the two fixtures shall be the same and shall be measured so that the error is no greater than 0.5 %.

NOTE 5—In Appendix X1, an alternative substrate and fixture arrangement is provided that has proved cost effective and simple.

6.1.1 *Material for Substrate Fixture*—The substrate fixture shall be constructed of metal, preferably metal intended for use as the substrate for the coating. If no such substrate material is specified, the substrate fixture shall be SAE 1018 or 1020 steel.

NOTE 6—If desired because of cost or ease of fabrication, it may be

suitable to attach or bond a layer of the specified substrate material to a fixture formed of any convenient metal. Such a layer of substrate material need not be metal. The layer must be substantially thicker than the possible depth of effects on the substrate, such as recrystallization or diffusion zones, that may result from applying the coating. A layer greater than 0.1 in. (2.5 mm) thick should be sufficient.

6.1.2 *Material for Loading Fixture*—The loading fixture shall be constructed of metal, but material is otherwise optional. It is usually convenient to make the loading fixture of the same material as the substrate fixture; thus, the fixtures may be interchangeable until a coating is applied to one.

6.2 *Coating Application*—The front facing of the substrate fixture shall be prepared in the manner required by the specification for the coating. (Roughening by grit blasting or surface grinding may be typical preparations.) The coating shall be thermal sprayed onto this prepared surface.

6.3 *Coating Thickness*—The coating thickness shall be measured with a micrometer by measuring the total length of the coating fixture before and after the coating is applied. (Care must be taken to avoid contaminating the prepared surface before coating.) The final coating thickness shall be more than 0.015 in. (0.38 mm). If the coating is to be ground or machined,

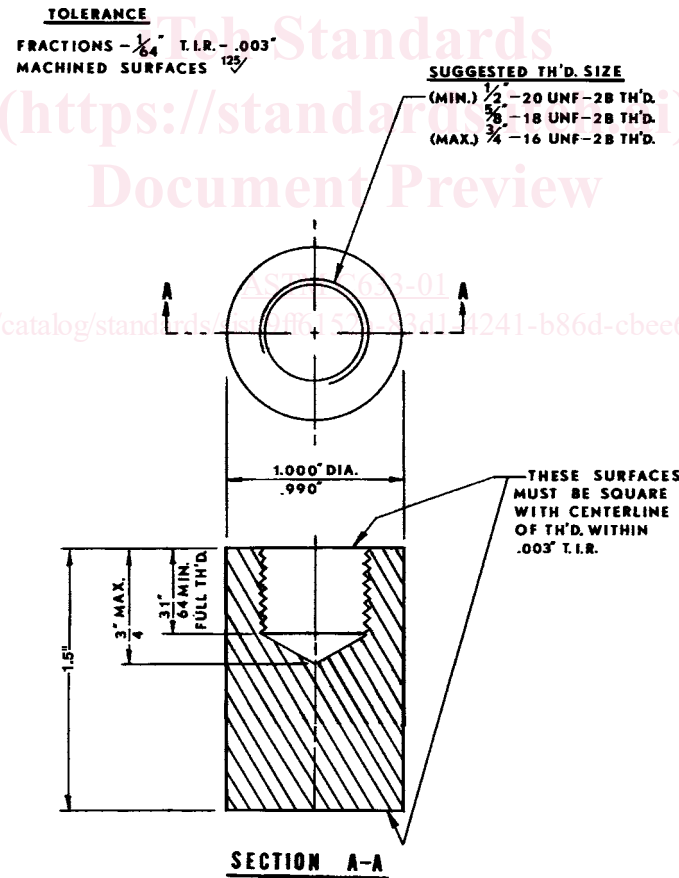

U.S.	0.003 in.	1/64 in.	3/16 in.	1/2 in.	5/8 in.	
Metric	(0.08 mm)	(0.39 mm)	(12.3 mm)	(12.7 mm)	(15.9 mm)	
U.S.	3/4 in.	0.990 in.	1 in.	1.000 in.	1 ft.	24 in.
Metric	(19 mm)	(25.15 mm)	(25.4 mm)	(25.4 mm)	(0.3 m)	(610 mm)

FIG. 2 Substrate and Loading Fixture