



Designation: E2349 – 18

Standard Practice for Safety Requirements in Metal Casting Operations: Sand Preparation, Molding, and Core Making; Melting and Pouring; and Cleaning and Finishing¹

This standard is issued under the fixed designation E2349; the number immediately following the designation indicates the year of original adoption or, in the case of revision, the year of last revision. A number in parentheses indicates the year of last reapproval. A superscript epsilon (ϵ) indicates an editorial change since the last revision or reapproval.

INTRODUCTION

This practice is part of a project started in 1972 under the sponsorship of the American Foundry Society, Inc. Standard for Safety Requirements in Metal Casting Operations—Sand Preparation, Molding, and Core Making; Melting and Pouring; and Cleaning and Finishing.

The metal casting industry shares safety considerations with many other industries requiring the movement of heavy objects, the use of large ovens and melt furnaces, and processing of hot materials. In addition, there are safety considerations common to all industries. The present trend is towards the development of industry-wide standards wherever the need for safety considerations exists. This practice, therefore, is limited to safety considerations of special importance in the metal casting industry operations in which general standards do not exist or are not considered adequate. This practice is not intended to supersede or replace any applicable federal, state, or local governmental safety regulations or requirements, but rather, it is intended to augment and support any such requirements. Operating rules are not included in this practice unless they are vital to safety.

Compliance with this practice should provide a relatively safe environment, which is a fundamental requirement in preventing occupational injuries.

Contents

Introduction

- 1 Scope
- 2 Referenced Documents
- 3 Terminology
- 4 Materials and Manufacture
 - 4.1 Responsibility
 - 4.2 Inherent Hazards
 - 4.3 Installation
 - 4.4 Power Requirements
 - 4.5 Electrical Ground Faults
 - 4.6 Fluid Power Off
 - 4.7 Electrical Equipment Grounding
 - 4.8 Fluid Exhaust (Gas or Liquid)
- 5 Care of Equipment – General Provisions
 - 5.1 Instructions
 - 5.2 Installation
 - 5.3 Inspection and Preventive Maintenance
 - 5.4 Maintenance Personnel Training and Experience
 - 5.5 Startup Procedure
 - 5.6 Shutdown Procedure
 - 5.7 Troubleshooting, Maintenance and Repair
- 6 Safeguards – General Requirements
 - 6.2 Responsibility for Safeguarding
 - 6.3 Guarding
 - 6.4 Hazard Zone Guarding
 - 6.5 Hazard Zone Protective Devices
 - 7 Operation of Equipment – General Requirements
 - 7.1 Employer's Responsibility
 - 7.2 Employee's Responsibility
- 8 Sand Preparation, Molding, and Coremaking
 - 8.1 Sand Handling and Preparation

- 8.2 Core Making
- 8.3 Molding Equipment
- 8.4 Fuel-Fired Equipment
- 8.5 Operation Procedures for Sand Preparation, Molding, and Coremaking
- 9 Melting and Pouring
 - 9.1 Cupola
 - 9.2 Electric Furnaces – Induction Melting and Induction Holding
 - 9.3 Electric Furnaces – Direct Arc Furnaces
 - 9.4 Ladles
 - 9.5 Molten Metal Handling and Pouring Equipment
 - 9.6 Maintenance and Inspection
 - 9.7 Molten Metal Treatment
 - 9.8 Specific Material Handling Equipment
 - 9.9 Molten Metal Handling and Pouring
 - 9.10 Overhead Handling of Molten Material
- 10 Cleaning and Finishing
 - 10.1 Care of Cleaning and Finishing Equipment
 - 10.2 Specific Equipment Safeguards – Cleaning and Finishing
 - 10.3 Abrasive Blasting
 - 10.4 Chipping
 - 10.5 Abrasive Wheels
 - 10.6 Operating Procedures for Abrasive Wheels
 - 10.7 Portable Abrasive Wheels
 - 10.8 Grinding Magnesium
 - 10.9 Molten Salts Cleaning
 - 10.10 Hooks Designed for Handling Castings
 - 10.11 Slings
 - 10.12 Lighting
- 11 Keywords

1. Scope

1.1 This practice covers the requirements of applying the design, construction, and operation of the machinery and equipment used in metal casting operations—sand preparation, molding and core making, melting and pouring, and cleaning and finishing. This practice does not apply to die casting operations.

1.2 *Purpose*—The requirements of this practice, including the training of supervisors and employees, are intended to minimize the possibility of injury to operating and maintenance personnel while working on, or in the vicinity of, the specified equipment. Compliance with this practice, in conjunction with OSHA regulations, provides a relatively safe environment, which is a fundamental requisite in helping to prevent occupational injuries.

1.3 Application:

1.3.1 *New Installations*—After the date of publication, all new installations within the scope of this specification shall be in conformance with its requirements. Any existing machine installation moved to a new plant or another location in the same plant is deemed a new installation when it is installed in the new location. However, an existing installed machine (former installation) that is moved for a short distance, for example, to provide additional aisle space, is not deemed to be a new installation.

1.3.2 *Existing Installations*—After the approval date of this practice, installations existing on, or before, this date, shall be modified as necessary to be in conformance with all requirements of this practice. Where it is not practical to modify an existing facility in conformance with this practice, deficiencies shall be noted and plans for compliance shall be included in any future facility or equipment changes. Those facilities and equipment on order or in the process of construction on the date of publication of this practice shall be considered as an existing installation. This practice applies to existing equipment if it lacks the necessary employee protection (personal protective equipment or administrative controls).

1.4 The values stated in inch/pound units are to be regarded as the standard. The values in brackets are for information only.

1.5 The text of this practice references notes and footnotes which provide explanatory material. These notes and footnotes (excluding those in tables and figures) shall not be considered as requirements of the standard.

1.6 *This standard does not purport to address all of the safety concerns, if any, associated with its use. It is the responsibility of the user of this standard to establish appropriate safety, health, and environmental practices and determine the applicability of regulatory limitations prior to use.*

1.7 *This international standard was developed in accordance with internationally recognized principles on standard-*

ization established in the Decision on Principles for the Development of International Standards, Guides and Recommendations issued by the World Trade Organization Technical Barriers to Trade (TBT) Committee.

2. Referenced Documents

2.1 ASTM Standards:²

E1542 Terminology Relating to Occupational Health and Safety

F1002 Performance Specification for Protective Clothing and Materials for Use by Workers Exposed to Specific Molten Substances and Related Thermal Hazards

F1449 Guide for Industrial Laundering of Flame, Thermal, and Arc Resistant Clothing

2.2 ANSI Standards:³

ANSI A12.64.1 Safety Requirements for Workplace, Floor and Wall Openings, Stairs and Railing Systems

ANSI A58.1 Minimum Design Load in Buildings and Other Structures

ANSI B5.35 Machine Mounting for Abrasive Discs and Plate Mounted Wheels

ANSI B 11.6 Safety Requirements for Manual Turning Machines with or without Automatic Control

ANSI B7.1 Safety Requirements for the Use, Care and Protection of Abrasive Wheels.

ANSI B11.9 Grinding Machines, Safety Requirements for the Construction, Care and Use of

ANSI B11 TR3 Risk Assessment and Risk Reduction—A Guide to Estimate, Evaluate and Reduce Risks Associated with Machine Tools

ANSI B15.1 Mechanical Power Transmission Apparatus

ANSI B20.1 Safety Standard for Conveyors and Related Equipment (ASME B20.1)

ANSI/ASME B30.2 Overhead and Gantry Cranes (Top Running, Bridge, Single or Multiple Girder Top Running Trolley Hoist)

ANSI/ASME B30.9 Slings

ANSI/ASME B30.10 Hooks

ANSI/ASME B30.11 Monorails and Underhung Cranes

ANSI/ASME B30.20 Below-the-hook Lifting Devices

ANSI B107.4 Driving & Spindle Ends for Portable Hand, Air and Electric Tools (Percussion Tools Excluded)

ANSI B186.1 Portable Air tools

ANSI Z9.2 Fundamentals Governing the Design and Operation of Local Exhaust Ventilation Systems

ANSI Z9.4 Ventilation and Safe Practices of Abrasive Blasting Operations

ANSI Z33.1 Standard for the Installation of Blower and Exhaust Systems (NFPA 91)

ANSI Z43.1 Ventilation Control of Grinding, Polishing/ Buffing

¹ This practice is under the jurisdiction of ASTM Committee E34 on Occupational Health and Safety and is the direct responsibility of Subcommittee E34.10 on Industrial Safety.

Current edition approved Oct. 1, 2018. Published November 2018. Originally approved in 2005. Last previous edition approved in 2012 as E2349 – 12. DOI: 10.1520/E2349-18.

² For referenced ASTM standards, visit the ASTM website, www.astm.org, or contact ASTM Customer Service at service@astm.org. For *Annual Book of ASTM Standards* volume information, refer to the standard's Document Summary page on the ASTM website.

³ Available from American National Standards Institute (ANSI), 25 W. 43rd St., 4th Floor, New York, NY 10036, <http://www.ansi.org>.

- ANSI Z244.1 Personnel Protection—Lockout/Tagout of Energy Sources—Minimum Safety Requirements
 ANSI Z490.1 Accepted Practices in Safety, Health and Environmental Training
 ANSI Z535.1 Safety Color Code
 ANSI Z535.2 Environmental and Facility Safety Signs
 ANSI Z535.3 Criteria for Safety Symbols
 ANSI Z535.4 Product Safety Signs and Labels
 ANSI Z535.5 Accident Prevention Tags
 2.3 NFPA Standards:⁴
 NFPA 49 Fire Protection Guide to Hazardous Materials
 NFPA 68 Guide for Venting of Deflagrations
 NFPA 70 National Electrical Code
 NFPA 86 Standard for Ovens and Furnaces
 NFPA 480 Standard for Storage and Handling of Magnesium
 NFPA 484 Standard for Combustible Metals
 2.4 Occupational Safety and Health Administration:⁵
 29 CFR 1910 Code of Federal Regulations, Part 1910 General Industry
 29 CFR 1910.23 Guarding Floor and Wall Openings and Holes
 29 CFR 1910.94(a) Ventilation—Abrasive Blasting
 29 CFR 1910.145 Specification for Accident Prevention Signs and Tags
 29 CFR 1910.146 Permit required Confined Spaces
 29 CFR 1910.147 Control of Hazardous Energy (LOCKOUT/TAGOUT)
 29 CFR 1910.184 Slings
 29 CFR 1910.215 Abrasive Wheel Machinery
 29 CFR 1910.217 Mechanical Power Presses

NOTE 1—State plan states may have their own regulations.

- 2.5 American Foundry Society (AFS):⁶
 Guide for Selection and Use of Personal Protective Equipment and Special Clothing for Foundry Operations Managing the Foundry Indoor Air Environment

3. Terminology

3.1 For definitions of terms used in this standard, see Terminology E1542.

3.2 Definitions:

3.2.1 *abrasive blasting, n*—operation in which an abrasive is forcibly applied to a surface by pneumatic or hydraulic pressure or centrifugal force.

3.2.2 *adjustable barrier guard, n*—physical barrier with adjustable sections that prevents entry of any part of the body into the hazard zone by reaching through, over, under, or around the barrier. The adjustable sections allow different jobs to be run on the equipment.

3.2.2.1 *Discussion*—This type of guard requires close supervision of use and adjustment or inadequate protection could result. It shall be the responsibility of the employer to establish

and follow a program of periodic and regular inspection of power press and auxiliary equipment. Refer to 29 CFR 1910.217(e).

3.2.3 *arc furnace, n*—see *direct arc furnace and indirect arc furnace*

3.2.4 *automatic, adv*—each function in the machine cycle is initiated by the previous cycle and is automatically performed and sequenced, including load, unload, and repeat cycle.

3.2.5 *bail/spreader, n*—hoop or arched connection between the crane hook and ladle or between crane hook and ladle trunnions.

3.2.6 *barrier guard*—see *adjustable barrier guard, fixed barrier guard, and interlocked barrier guard*.

3.2.7 *blast, n*—air or oxygen-enriched air that is blown, under pressure into a cupola for supporting combustion.

3.2.8 *blast compartment, n*—that portion of the blasting enclosure that contains the blasting media propulsion device.

3.2.9 *blow plate, n*—plate affixed to the magazine or blow head of a core- or mold-blowing machine having holes or slots through which sand or other media in the magazine or blow head passes into the core or mold cavity or around the pattern when air or other gas pressure is applied to the machine.

3.2.10 *bottom discharge (pour, tap) ladle, n*—ladle that has its molten metal contents discharged through an opening in the bottom.

3.2.11 *channel furnace, n*—electric induction furnace in which heat is electrically induced in the metal in a refractory channel.

3.2.12 *charge, n*—material introduced into a melting furnace for the production of molten metal.

3.2.13 *charging, v*—process of adding a charge to a furnace.

3.2.14 *control circuit (electrical), n*—circuit of a control apparatus or system that carries the electric signals directing the performance of the controller, but does not carry the main power current.

3.2.15 *controller, n*—device or group of devices that serves to govern, in some predetermined manner, the electric power delivered to the apparatus to which it is connected.

3.2.16 *core, n*—preformed aggregate or collapsible insert placed in a mold to shape the interior or that part of a casting that cannot be shaped by the pattern.

3.2.17 *core binder(s), n*—any material, liquid or solid, which is used to bond core aggregates.

3.2.18 *corebox, n*—a (wood, metal, or plastic) structure, the cavity of which has the shape of the desired core that is to be made therein.

3.2.19 *coreless furnace, n*—electric induction furnace consisting of an induction coil surrounding a crucible or refractory lining in which metal is melted or molten metal is retained.

3.2.20 *core- or mold-blowing or shooting machine, n*—machine for injecting sand or other media into the core or mold cavity by means of compressed air or other gas.

⁴ Available from National Fire Protection Association (NFPA), 1 Batterymarch Park, Quincy, MA 02169-7471, <http://www.nfpa.org>.

⁵ Available from Occupational Safety and Health Administration (OSHA), 200 Constitution Ave., NW, Washington, DC 20210, <http://www.osha.gov>.

⁶ Available from the American Foundry Society, 1695 N. Penny Lane, Schaumburg, IL 60173.

3.2.21 *counterweight*, *n*—weight that corrects a state of unbalance and establishes static equilibrium.

3.2.22 *crane ladle*, *n*—ladle handled by an overhead crane.

3.2.23 *crucible*, *n*—container used for the melting, holding, and pouring of metal.

3.2.24 *cupola*, *n*—vertical shaft-type furnace for melting and/or producing molten metal by combusting coke or other fuels using a blast, and possibly additional pure oxygen, that is introduced through the cupola tuyeres.

3.2.25 *cupola drop*, *n*—materials dropped from the cupola at the end of a heat.

3.2.26 *direct arc furnace*, *n*—furnace in which heat is produced by an electric arc between electrodes and the charge.

3.2.27 *disconnecting means (electrical)*, *n*—device, or group of devices, or other means by which it is possible to disconnect the conductors of the circuit from their source of supply.

3.2.28 *disconnect switch (electrical)*, *n*—switching device used primarily for isolating a circuit or equipment from a source of power.

3.2.29 *drop area*, *n*—the area directly under the cupola that receives the hot bed coke or other hot materials from the inside of the furnace when the bottom doors or side access door are opened.

3.2.30 *drop zone*, *n*—the zone adjacent to the drop area that is exposed to drop hazards during the dropping process.

3.2.31 *dross*, *n*—metal oxides or foreign matter or both that accumulates on the surface of nonferrous molten metal.

3.2.32 *dust collector*, *n*—air-cleaning device to remove particulate matter from exhaust systems before discharge to the atmosphere.

3.2.33 *exhaust system*, *n*—system of air-moving equipment and ducts used to remove airborne contaminants from affected areas.

3.2.34 *explosion vent*, *n*—a device that is engineered as part of an enclosure, container, or vessel that is designed to release pressure rapidly.

3.2.35 *finishing*, *v*—attainment of a desired surface finish or finish characteristics by such means as abrasive impingement, grinding, or polishing.

3.2.36 *fixed barrier guard*, *n*—securely attached physical barrier, not readily removable, that prevents entry of any part of the body into the hazard zone by reaching through, over, under, or around the barrier.

3.2.37 *flame detector*, *n*—device, which senses the absence or presence of flame, for the purpose of controlling fuel line valves.

3.2.38 *flask*, *n*—container, without top or bottom, used to contain the sand or other media while it is being formed. It is made in two or more parts, the lower part called the drag and the upper part called the cope. Intermediate sections, if any, are called cheeks.

3.2.39 *flask lifting device*, *n*—chains, rods, bails, cables, slings and other materials used to support a load such as a flask for turning, inverting, or transporting.

3.2.40 *fuel-fired equipment (enclosed)*, *n*—specially heated chamber such as core oven, drying oven, thermal sand reclamation, sand heater, or annealing oven.

3.2.41 *gas handling system*, *n*—the collective group of equipment that draws cupola gas from the furnace.

3.2.42 *guarded*, *adj*—shielded, fenced, enclosed, or otherwise protected by means of suitable enclosure, covers, casing, shield guards, trough guards, barrier guard, railing guards, or guarded by location, or other protective devices, so as to reduce the possible risk of personnel injury from accidental contact or approach, or in the case of spill guards, so as to reduce possibility of personnel injury from material being spilled into the area protected. Where it is not feasible to guard against the hazard, or where the guard itself creates a hazard, the potential hazard shall be marked prominently to warn of its existence.

3.2.43 *guarded by location*, *adv*—to be guarded by location or position in accordance with the height above a walkway, platform, or workspace, any moving part shall be at least 8 ft (2.46 m) above same. However, pinch points of all descriptions and moving projections shall not be guarded by location unless they are a minimum of 9 ft (2.74 m) above the pertinent floor. When moving parts are remote from floors, platforms, walkways, other working levels, or by their location with reference to frames, foundations, or structures that minimize the probability of accidental contact by personnel, they shall be considered to be guarded by position or location. Remoteness from regular or frequent presence of public or employed personnel, in reasonable circumstances, constitutes guarding by location.

3.2.44 *hazard*, *n*—a condition or series of conditions, either continuous, intermittent or instantaneous in nature that exists, or could exist, such that bodily injury could result. Hazards include, but are not limited to, falling, pinching, crushing, cutting, impaction, burning, concussion, suffocation, occupational disease, asphyxiation and/or electrocution.

3.2.45 *hazard point*, *n*—closest point within the hazard zone at which physical contact occurs between machine elements or materials or both.

3.2.46 *hazard zone*, *n*—that area where a hazard exists and bodily injury could result upon direct exposure or contact with that hazard.

3.2.47 *heat*, *n*—stated weight of metal obtained from a period of melting in a cupola or furnace or the time required to melt and process this material.

3.2.48 *hopper*, *n*—bulk container in which materials are stored.

3.2.49 *hostage control*, *n*—type of control in which the physical act of operating the initiator prevents operator exposure to the motion or response produced by the initiator.

3.2.49.1 *Discussion*—An initiator located a sufficient distance from the hazard zone that the operator cannot reach the point of operation during the hazardous portion of the cycle, after operating the initiator, is an example.

3.2.50 *hostage protection, n*—means of minimizing personnel exposure to hazards by making it easier to perform an operation in a prescribed manner through work piece or machine design or both.

3.2.51 *inch control, n*—hostage control, which causes machine motion in single or repeated small increments only when controlled by manual pressure.

3.2.51.1 *Discussion*—It is intended for use in setup or maintenance, but not in normal operation.

3.2.52 *indirect arc furnace, n*—furnace in which heat is produced by an electric arc between electrodes.

3.2.53 *induction furnace*—see *channel furnace and coreless furnace*

3.2.54 *initiator, n*—device that causes an action of control(s) or power.

3.2.54.1 *Discussion*—Typical operator initiators are pushbuttons, foot switches, manual starters, hand valves, and other valves with manual overrides. Typical non-operator initiators are limit switches, pressure switches, temperature-actuated switches, flow switches, and cam-actuated valves.

3.2.55 *inspections, frequency of, n*—frequent—daily to monthly intervals and periodic—from one- to twelve-month intervals.

3.2.56 *interlock, n*—device in a system which, when actuated, permits or prevents the operation of one or more components in the system.

3.2.57 *interlocked barrier guard, n*—barrier interlocked with the machine power or control so that the machine cycle will stop and cannot be initiated with the operating controls unless the guard, or the hinged or movable sections, effectively encloses the hazard zone.

3.2.58 *isolation switch*—see *disconnect switch*

3.2.59 *jamming (hooking), v*—jamming (hooking) occurs when the work rest becomes improperly adjusted to such an extent that the work piece is pulled between the abrasive wheel and the leading edge of the work rest by the grinding action of the wheel resulting in possible injury to personnel.

3.2.59.1 *Discussion*—Jamming (hooking) should not be confused with the use of work rest mounted tooling, pins, or pressure bars.

3.2.60 *ladle handler, n*—mechanism used to suspend, transport, raise and/or lower a ladle.

3.2.61 *ladle pouring stand, n*—structural device for supporting or tilting a ladle or both.

3.2.62 *lance, oxygen, n*—device consisting of steel pipe, tubing, oxygen source, and controls.

3.2.62.1 *Discussion*—Frequently used to open frozen tap or slag holes; also occasionally to oxidize impurities in molten metal bath.

3.2.63 *lip, n*—formed “U” or “V” depression in a molten metal outlet to confine the stream.

3.2.64 *main burner, n*—primary combustion device commonly ignited by a secondary source.

3.2.65 *mandatory safety standards, n*—those safety standards that are legally enforceable by agencies of federal, state, or local government.

3.2.66 *manual, adj*—each machine function in the machine cycle and load cycle is manually initiated and controlled in the sequence or out of the sequence of the normal machine cycle.

3.2.67 *manually powered machines, n*—machine in which the operator provides the motive power to operate the machine.

3.2.68 *manual mode, n*—method of operation that requires manual initiation of each function in the equipment cycle.

3.2.69 *mold, n*—form that contains the cavity into which molten metal is poured to produce a casting of definite shape and outline.

3.2.70 *molding machine, n*—machine for compacting molding media (usually sand) about the pattern(s), thus forming the mold.

3.2.71 *moving frame, n*—that part of a molding machine that supports the flask and imparts the motions necessary to the mold making process.

3.2.72 *muller, n*—machine that blends, coats, kneads, or mechanically combines various sand(s) or other media used for foundry purposes with binders and other additive agents. Typically, it consists of a circular container in which rotating plows or mill wheels (mullers) or both are mounted.

3.2.73 *nip point, n*—point or zone in which a part of the body could be caught and squeezed between two surfaces, edges, or points.

3.2.74 *operator’s work zone(s), n*—operator’s work zone(s) of equipment is that area in which the operator’s presence is required while operating in the intended manner.

3.2.74.1 *Discussion*—An employee’s presence applies to the entrance into the operator’s work zone of the employee’s body or any part thereof.

3.2.75 *pattern, n*—form of wood, metal, or other material against which molding material is compacted to make a mold for casting metals.

3.2.76 *pilot (flame or spark), n*—auxiliary source that ignites the main burner.

3.2.77 *pinch point, n*—zone in which a portion of the body could be caught and injured between surfaces, edges, or points.

3.2.78 *point of operation, n*—that point or zone in which the principal operation is being performed.

3.2.79 *pouring, n*—final transfer of molten metal before its solidification into its intended form.

3.2.80 *pouring area, n*—location in a foundry where molten metal is poured into molds or transferred from a ladle to a furnace.

3.2.81 *power locked off, n*—state in which the device that turns power off is locked in the off position with the padlock of every individual who is working on the machine. Locks are affixed directly to the power disconnect, to a group lockout device, group lockbox, or comparable mechanism.

3.2.82 *power off or out, n*—state in which power cannot flow to the equipment from the source (see 4.4).

3.2.83 *presence-sensing device, n*—device designed, constructed, and arranged to create a sensing field or area that will detect either the presence or absence of personnel.

3.2.84 *protection from unexpected machine movement, n*—see *protection, primary and protection, secondary*.

3.2.84.1 *Discussion*—There are hazards other than unexpected movement, and the OSHA machine lockout/tagout standard 29 CFR 1910.147 includes protection against such other hazards.

3.2.85 *protection, primary, n*—state in which the primary source(s) of power has been isolated by being locked out (off) and in which stored energy in the machine has been dissipated, constrained, or controlled. The state in which OSHA lockout/tagout has been established.

3.2.85.1 *Discussion*—Locking out the power to an electric drive motor by means of the main disconnect switch is an example of primary protection against hazards related to the running of the motor.

3.2.86 *protection, secondary, n*—limited protection by control devices.

3.2.86.1 *Discussion*—It is possible for control devices, like limit switches, to malfunction mechanically or electrically, and interlocks intended for safety purposes are sometimes bypassed or wedged or tied in actuated states. Secondary protection is only justifiable when there is no practical alternative, that is, when primary protection is not practical and when regular disciplined maintenance is present. The operator, whose constant attitude should be one of caution, should understand the fact that operator protection devices such as interlocked guards are secondary protection. Frequent inspections of such protective devices should be made. Locking a STOP push button in the actuated position instead of using OSHA lockout/tagout is an example of a dangerous attempt to use secondary protection against machine movement.

3.2.87 *protective device, n*—means whereby personnel access to a hazard zone or area is denied by other than a physical guard.

3.2.87.1 *Discussion*—Protective devices include, but are not limited to, two-hand controls, two-hand trips, and hostage controls.

3.2.88 *puncture point, n*—zone in which a part of the body could be punctured or perforated.

3.2.89 *qualified engineer, n*—qualified engineer is one who possesses an engineering degree from an accredited institution of higher learning or a certificate of professional standing and has engineering experience with the kind of work and equipment involved.

3.2.90 *qualified person, n*—person determined by the employer to have the training or experience or both to operate or maintain or both the equipment involved.

3.2.91 *reactive metal, n*—any metal that is readily oxidized with the release of large quantities of heat.

3.2.92 *runout pit, n*—pit placed below or in front of a furnace or both to receive molten material in an emergency.

3.2.93 *safety, n*—state of being reasonably free or reasonably protected from injury or risk. Never to be construed as absolute or perfect protection from harm, injury, or risk.

3.2.94 *sand mixer, n*—machine for conditioning mold and core sand by controlled mixing with additives.

3.2.95 *sand muller, n*—machine for conditioning mold and core sand by controlled mixing with additives.

3.2.96 *sand system, n*—that part of a foundry installation that processes and transports sand or other media in bulk form.

3.2.97 *screen (sand), n*—sieve or riddle with openings of definite size used to separate one grain size from another or to remove lumps and foreign objects from sand.

3.2.98 *semi-automatic, adj*—at least one machine function in the cycle is automatically performed and sequenced, but which requires the operator to initiate at least one function manually.

3.2.99 *semiautomatic mode, n*—method of operation in which at least one function in an equipment cycle requires manual initiation and at least one function is automatically sequenced.

3.2.100 *shear pin, n*—pin built into a mechanism designed to fail under specified loading and act as an overload disconnect.

3.2.101 *shear point, n*—point or zone in which body parts could be caught by one machine member moving past another.

3.2.102 *shutdown, n*—planned steps required to take machine or process out of operation.

3.2.103 *skimming, n*—removing slag or dross from the surface of the molten metal.

3.2.104 *skip hoist, n*—basket, bucket, or other container that is drawn or elevated on rails by a pulling or pushing action.

3.2.105 *slag, n*—nonmetallic byproducts and contaminants generated during the melting, transferring, and holding of molten metal.

3.2.106 *slagging, v*—see *skimming*.

3.2.107 *slag hole or door, n*—opening in the furnace through which slag is removed.

3.2.108 *slinger, n*—machine that throws sand or other media into a flask, corebox, or other container.

3.2.109 *start up, n*—planned steps required to place a machine or process into operation.

3.2.110 *stop block, n*—rigid restraining device that will prevent hazardous movement of a machine or equipment member(s). A stop block shall be designed and constructed to withstand the forces to which it will be subjected.

3.2.111 *tapping, v*—removing molten material from the furnace by opening a tap hole.

3.2.112 *transfer car, n*—vehicle used for transporting vessels or material(s), usually in a fixed path.

3.2.113 *trunnions, n*—shafts used to support, turn, or tilt a vessel.

3.2.114 *tumbling barrel, n*—power-driven rotating drum or barrel in which castings are cleaned or polished or both. The castings act as abrasives for each other or are tumbled in an abrasive media.

3.2.115 *tuyere, n*—nozzle opening through which the blast enters a cupola.

3.2.116 *two-hand control, n*—type of control in which the operator causes a motion by manually operating an initiator concurrently with each hand, the motion stopping or reversing upon deactuation of either or both initiators.

3.2.117 *two-hand trip device, n*—type of control in which the operator causes a motion by manually operating an initiator concurrently with each hand, the motion continuing to completion whether the initiators continue to be held actuated or not.

3.2.118 *work zone and work station, n*—see *operator's work zone(s)*

4. Materials and Manufacture

4.1 *Responsibility*—It shall be the responsibility of any person purchasing, constructing, reconstructing, or modifying any equipment covered by this practice to:

4.1.1 Design, construct, and modify equipment in accordance with the provisions of this practice. (Consider other applicable safety standards.)

4.1.2 Select and include in construction only components that have a working rating equal to or greater than required to meet the maximum recommended operating condition(s).

4.1.3 Furnish printed instructions with each unit of equipment. (To minimize hazards, it is essential that this material be readily available to maintenance, operations, and engineering personnel.) The instructions shall include:

4.1.3.1 Engineering drawings and other materials required to install and place such equipment into operation properly.

4.1.3.2 Operating and maintenance instructions as specified in Section 5.

4.1.3.3 Spare parts lists.

4.1.3.4 Procedures in accordance with 29 CFR 1910.147 OSHA lockout/tagout standard shall be followed.

4.1.4 Hazard alert signs when used shall comply with the following standards: ANSI Z535.1 Safety Color Code, ANSI Z535.2 Environmental and Facility Safety Signs, ANSI Z535.3 Criteria for Safety Symbols, ANSI Z535.4 Product Safety Signs and Labels, ANSI Z535.5 Accident Prevention Tags.

4.1.5 Apply a legible identification plate to each piece of equipment. This plate shall include as a minimum the manufacturer's name, equipment type or model identification or both, serial number, and rated capacity(s).

4.1.6 Ensure that any modification(s) or alteration(s) to a piece of equipment or machinery covered by this practice that result in a change from the manufacturer's original design or intended method of operation or both shall be done under the supervision of a qualified engineer and shall comply with mandatory safety standards for that given category of equipment. An additional legible identification plate shall be attached to the machine or equipment adjacent to the manufacturer's original identification plate (see 4.1 (5)). The new identification plate shall state the date the modification(s) was made and the person or organization responsible. (Restrictions on modifications or alterations are not intended to bar repair or maintenance including the substitution of substantially equivalent components.)

4.2 *Inherent Hazards:*

4.2.1 *Hazards to Personnel Associated with Moving Parts*—Hazards to personnel associated with moving parts (other than point of operation hazards) shall be guarded in accordance with ANSI B15.1 or ANSI B20.1, as appropriate.

4.2.1.1 *Discussion*—Some examples of hazards to personnel associated with moving parts are:

(1) Rotating components, such as flywheels, gears, sheaves, and shafts in proximity to personnel;

(2) Run-in pinch points, such as meshing gears, belts, and chains; and

(3) Pinch points between the moving and stationary components of the machine.

4.2.1.2 *Responsibility – Manufacturer*—The manufacturer shall endeavor to eliminate the hazards by design or provide protection against them. When hazards cannot be eliminated by design or protection, the manufacturer shall warn against them by using signs in accordance with ANSI Z535.1, 2, 3, 4, 5, as appropriate.

4.2.1.3 *Discussion*—Together, these five ANSI standards contain information needed to specify formats, colors, and symbols for safety signs used in environmental and facility applications, product applications, and accident prevention signs.

4.2.1.4 *Responsibility – Employer*—Equipment with moving parts that could cause injuries to personnel shall be guarded.

4.2.2 *Hazards to Personnel Associated With the Point of Operation*—Refer to Section 6.

4.2.3 *Hazards to Personnel Associated With Broken, Falling, or Flying Equipment Components*—The manufacturer shall design, secure, or cover machine components to minimize hazards caused by falling or flying components resulting from loosening or breakage.

4.3 *Installation:*

4.3.1 *Employer Responsibility*—The employer shall be responsible for safe conditions for installing the equipment covered by this practice.

4.3.2 *Safeguarding During Construction, Reconstruction, or Modification*—Use of barriers, shields, and covers over excavations, pits, or tanks shall be required and used. Means shall be provided to prevent unauthorized persons from entering an area or zone in which construction or repair is in progress.

4.3.2.1 *Discussion*—ANSI A12.64.1 contains the appropriate requirements and recommendations.

4.3.3 *Workstation*—Each workstation shall have space to permit work without physical interference from equipment or another employee(s) within that workstation. Services, including electric power, air hydraulic, water, steam, or process liquids, shall be delivered in identified conductors with shutoff valves or disconnecting means legibly marked, and shall be visible and accessible.

4.4 *Power Requirements:*

4.4.1 *Disconnect Means*—All motors, motor circuits, and controllers shall have disconnecting means as required by

Article 430 of the National Electric Code (ANSI/NFPA 70). The disconnecting means shall be capable of being locked in the (OFF) position.

4.4.1.1 *Disconnect Means Identification*—Each disconnect means shall be marked with a legible durable label that identifies the voltage and equipment controlled. Identification shall be verified at time of installation.

4.4.1.2 *Disconnection:*

(1) Control circuits shall be so arranged that they will be disconnected from all sources of power when disconnecting means is in the open (OFF) position.

(2) There shall be an interlock, on separate power source feeds, that opens when the main disconnect is opened.

(3) The disconnecting means consists of two or more separate devices, one of which disconnects the motor and the controller from the source(s) of power supply for the motor, and the other disconnects the control circuit(s) from its power source. Where separate devices are used, they shall be located immediately adjacent, one to the other.

4.4.1.3 *Disconnection Hazards*—Where the operation of a disconnecting means could create a hazard, a suitable hazard alerting nameplate shall be provided and located adjacent to the label required in 4.4.1.1

4.4.1.4 *Motor-Starting Equipment*—Motor-starting equipment with the potential to restart a motor automatically after an unplanned power interruption or power outage shall not be used when automatic restarting would potentially result in injury to personnel. It shall be necessary to restart the motor manually.

4.4.2 *Electrical Power Off – Electrical Panels or Electrical Furnaces:*

4.4.2.1 *Disconnect Means*—All control and power circuits shall be equipped with disconnecting means that have the capability to be locked in the open (OFF) position for the protection of the operating or maintenance personnel.

4.4.2.2 *Isolation (Disconnect) Switches*—Isolation switches not capable of interrupting load current shall not be opened under load and shall be provided with signage warning against opening under load.

4.4.2.3 *Discussion*—Where possible, these isolation switches shall be key interlocked with the circuit-interrupting device so that the isolation switch cannot be opened under load. Individual consideration shall be given to keep these switches in a locked closed (ON) condition during normal operation.

4.4.2.4 *Door Interlock*—All doors providing access to electrical circuits that operate at over 50 V shall be interlocked to disconnect electrical power when the door is opened. If voltages in excess of 50 V remain after electrical power has been disconnected, hazard alert signs shall be provided.

4.4.2.5 *Discussion*—While power has been disconnected when the door is opened, electrical power remains at the primary terminals. In addition, in some instances capacitors will remain charged and must be discharged to remove all voltage from the circuits inside the cabinet.

4.4.3 *Fluid Power Off*—Means shall be provided for isolating fluid (air, oil, or other) energy sources from a machine, or group of machines, controlled as a system. These means shall

have provisions for being locked in the isolating mode. Pressure buildup on the machine side port of the isolating means shall be eliminated by positive means such as venting to atmosphere or drainage to tank.

4.5 *Electrical Ground Faults:*

4.5.1 *Grounded Control Circuit*—When one side of the control circuit is grounded, the control circuit shall be designed so that an accidental ground will not start a motor, energize any component, or cause a machine movement.

4.5.1.1 *Discussion*—Circuits that have all coils or solenoid(s) common to the grounded side of the control circuit, without intervening contacts, will almost always meet these requirements on a circuit that is grounded. It is possible that circuits that do not have this characteristic are hazardous in that an accidental ground might cause unwarranted energization or machine movement or both.

4.5.2 *Ungrounded Control Circuit*—Ungrounded control circuits shall have operative ground-indicating lights. An indicated ground shall be reported at once by the employee and investigated immediately. If a personnel hazard exists, corrections shall be made before resuming operation of the equipment.

4.5.2.1 *Discussion*—Without grounds, each light has only one half voltage and both lights are therefore equally dim—the normal condition. A ground causes one light to glow brightly, the other to dim or go out. Depending upon the location of the accidental ground this indication is usually either constant or intermittent during operations. In an ungrounded system, it is not clear whether the first accidental ground will indicate a personnel hazard possible with the second accidental ground—or with simultaneous double accidental grounding.

(1) For instance, a ground on the common coil side of the control circuit will in effect merely convert the ungrounded circuit into a grounded circuit. The remarks in 4.5.1 and the Discussion in 4.5.1 are then applicable.

(2) However, where the first accidental ground is on the contact side, it could possibly create a personnel hazard. This potential hazard must be resolved by authorized personnel.

4.6 *Fluid Power Off*—Means shall be provided for isolating fluid (air, oil, or other) energy sources from a machine, or group of machines, controlled as a system. These means shall

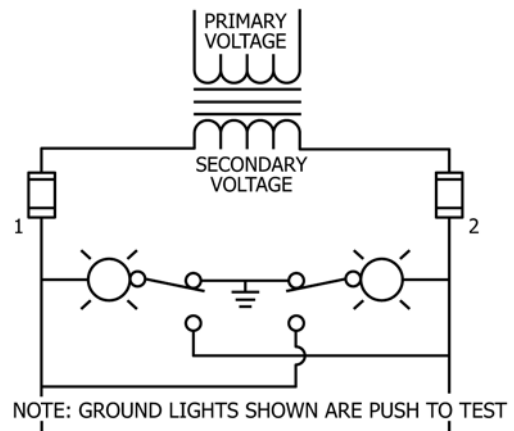

FIG. 1 Ungrounded Control Circuit

have provisions for being locked in the isolating mode. Pressure buildup on the machine side port of the isolating means shall be eliminated by positive means such as venting to atmosphere or drainage to tank.

4.7 *Electrical Equipment Grounding*—All electrical equipment shall be grounded in accordance with the National Electrical Code.

4.8 *Fluid Exhaust (Gas or Liquid)*—The employer shall be responsible for arranging conductors to direct the exhaust of fluids to a location(s) that will not create a hazardous condition.

5. Care of Equipment – General Provisions

5.1 *Instructions:*

5.1.1 *Manufacturer*—The manufacturer shall furnish operating and maintenance instructions with equipment covered by this practice. These shall be in conformance with 29 CFR 1910.147 OSHA lockout/tagout.

5.1.1.1 *Discussion*—Most operating and maintenance manuals provide specific instructions to aid in the proper operation and maintenance of the equipment. Optional means to provide adequate instructions include written, illustrated, audio, and visual recorded material. However, the employer is responsible for making sure all equipment is adequately guarded and safe for operation.

5.1.2 *Modification/Reconstruction*—Any person modifying or reconstructing any piece of equipment covered by this practice shall furnish operating and maintenance instructions, including updated functional engineering drawings of controls covering the modified portion of the equipment. Refer to Section 4.

5.1.2.1 *Discussion*—Many modification and rebuilding efforts are so extensive that the original instructions from the manufacturer are incorrect or meaningless.

5.1.3 *Employer*—The employer shall specify corrective maintenance procedures for the equipment covered by this practice that minimize hazards to operating and maintenance personnel.

5.2 *Installation*—The employer shall provide work areas around the equipment covered by this practice to minimize hazards to operating and maintenance personnel.

5.3 *Inspection and Preventive Maintenance*—The employer shall establish and supervise a program of documented inspections and preventive maintenance of the equipment covered by this practice. Designated personnel shall perform the required inspections and maintenance.

5.3.1 The frequency of inspecting the equipment is based on the manufacturer's recommendations, the number of hours used per month, and the maintenance history. The employer shall schedule frequent or periodic inspections or both that would reveal hazards caused by age, overloading, corrosion, fatigue, improper use, or improper installation.

5.4 *Maintenance Personnel Training and Experience*—The employer shall provide trained and competent personnel for maintaining the equipment covered by this practice.

5.4.1 Competent maintenance personnel shall have the technical background necessary to understand the information

contained in the maintenance manuals for the machine they are inspecting or maintaining.

5.5 *Startup Procedures:*

5.5.1 *Manufacturer*—The manufacturer shall recommend a startup procedure that minimizes hazards.

5.5.2 *Employer*—The employer shall establish and follow a startup procedure considering the manufacturers' recommendations before any equipment covered by this practice is placed in regular operation.

5.5.3 *Employee*—The employee shall follow the startup procedure established by the employer.

5.6 *Shutdown Procedure:*

5.6.1 *Manufacturer*—The manufacturer shall recommend a shutdown procedure that minimizes hazards.

5.6.2 *Employer*—The employer shall establish and follow a shutdown procedure considering the manufacturer's recommendations for necessary lockouts before allowing any inspection, adjustments, or maintenance of the equipment covered by this practice.

5.6.3 *Employee*—The employee shall follow shutdown, lockout, and safeguarding procedures established by the employer.

5.7 *Troubleshooting, Maintenance, and Repair:*

5.7.1 *Employer*—The employer shall provide training for employees engaged in troubleshooting, maintenance, or repair in isolated or hidden areas. For work in confined spaces entry procedures shall be in conformance with 29 CFR 1910.146.

5.7.2 *Employee*—The employee shall use the monitoring means established by the employer to inform others of his or her presence when performing maintenance or setup work in hidden or isolated areas.

5.7.3 *Physical Entry Into Machine or Equipment*—The employee shall follow established lockout/tagout and confined space procedures for the machine or equipment before physical entry.

5.7.3.1 *Discussion*—It is possible that the rules for confined space or permit required confined space or both will also apply.

5.7.4 *Troubleshooting, Maintenance, and Repair With Power On*—Exception for qualified persons only: When necessary to locate and define problems and make adjustments with power on, qualified persons are allowed to perform work on machines or equipment with guards removed or within areas protected by barriers, if protective measures have been taken to train and supervise the employees to not place any part of the body in the path of any movable machine or equipment member or in contact with any hazardous energized electrical equipment. Employees shall follow OSHA regulations 29 CFR 1910.331, 29 CFR 1910.332, 29 CFR 1910.333, 29 CFR 1910.334, and 29 CFR 1910.335.

5.7.5 *Defeating Protective Devices*—No employee other than authorized and qualified personnel performing special maintenance shall remove, bypass, or alter any device that was provided to reduce hazardous conditions.

5.7.5.1 This practice does not condone defeating any protective device at any time. This practice does, however, recognize that maintenance conditions exist when authorized

maintenance personnel would be permitted to bypass the protective device. Under such conditions, 5.7.4 shall be strictly followed.

5.7.6 *Returning Equipment to Production*—The employee shall verify that the machine or equipment has all guards secured in place and operators have been informed before releasing it for production use.

6. Safeguards – General Requirements

6.1 *Discussion*—Refer to the definitions “protection-primary” and “protection-secondary.”

6.2 *Responsibility for Safeguarding:*

6.2.1 *Discussion*—It must be understood that in the application of this practice, there are responsibilities incumbent upon the employer, the manufacturer, the installer, and the operator of foundry equipment. (See ANSI B11.6, ANSI B11.9 and ANSI B11 TR3 on hazard analysis and risk assessment.) Some safety features are incorporated in the design of the equipment. Some protection depends on installation after assembly of all of the associated components in the field. Some safety features are a part of a building or structure and are not an integral part of the components themselves. Some protection depends on the operation and maintenance by the employer and operators. Some protection depends on training and supervision.

6.2.2 *Manufacturer*—The manufacturer of equipment shall furnish equipment that complies with mandatory safety standards for that given category of equipment.

6.2.3 *Employer*—The employer shall be responsible for the installation and maintenance of guards, shields, or barriers and for maintaining the condition and position of such devices to protect against recognized hazardous conditions. The employer shall be responsible for providing, installing, and maintaining any additional guards required to provide protection against recognized hazardous conditions created by the use or installation or both of the equipment.

6.3 *Guarding*—Potential hazards including, but not limited to, nip, pinch, shear, puncture, or catching points, or a combination thereof shall be guarded.

6.3.1 *Exception*—The requirement does not apply when:

6.3.1.1 The exposed pinch point openings in conformance with Table 1 and Fig. 2. Figure 2 shows the accepted safe openings at the bottom edge of a guard at various distances from the hazard point.

6.3.1.2 Manual operation, such as placing copes on drags, manually closing molds, with or without mechanical assists, shall be excluded from mandatory guarding where variable conditions preclude the use of barriers or devices. For these operations, special emphasis shall be given to operator training.

6.4 *Hazard Zone Guarding:*

6.4.1 *Discussion*—Guarding within that area of the operator’s work zone where the work process is being performed.

6.4.2 *Hazard Zone Guard(s)*—Every hazard zone guard shall meet the following design, construction, application, and adjustment requirements:

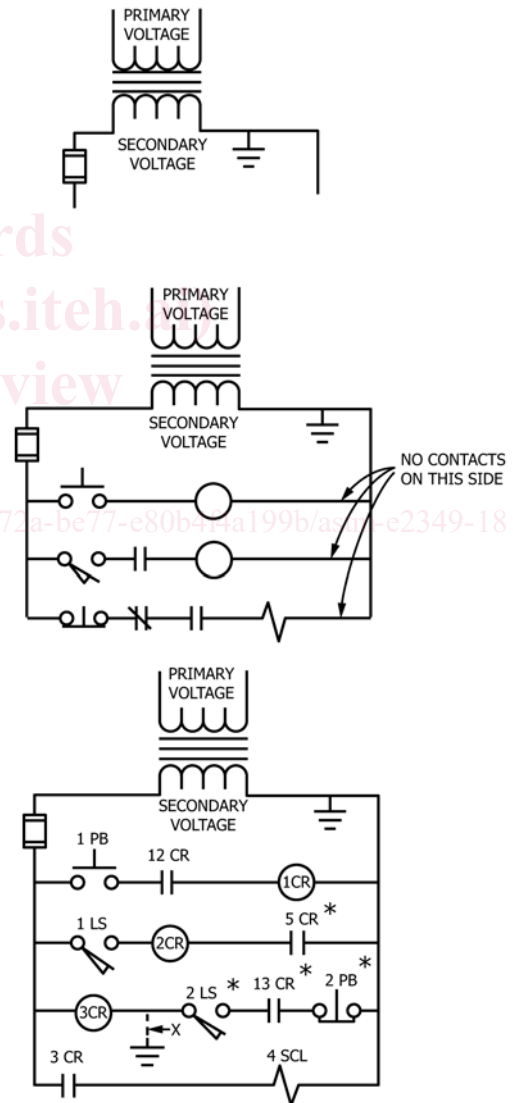

NOTE 1—Location marked with “*” purposely shown incorrect for illustration. For instance, if an accidental ground occurred at “X,” 3CR coil would always be energized with power on.

TABLE 1 Accepted Safe Opening Between Guard and Hazard Zone

NOTE 1—Source: 29 CFR 1910.217 Table 0-10.

Distance of Opening from Hazard Zone (in.)	Maximum Width of Opening		
	(mm) ^A	(in.)	(mm) ^A
1/2 – 1 1/2	13–38	1/4	6
1 1/2 – 2 1/2	38–64	3/8	10
2 1/2 – 3 1/2	64–89	1/2	13
3 1/2 – 5 1/2	89–138	5/8	16
5 1/2 – 6 1/2	138–165	3/4	19
6 1/2 – 7 1/2	165–191	7/8	22
7 1/2 – 12 1/2	191–318	1 1/4	32
12 1/2 – 15 1/2	318–394	1 1/2	38
15 1/2 – 17 1/2	394–445	1 7/8	48
17 1/2 – 31 1/2	445–800	2 1/8	54

^A Approximate.

FIG. 2 Control Circuits

6.4.2.1 It shall prevent entry of any part of the body into the hazard zone by reaching through, over, under, or around the guard.

6.4.2.2 It shall be in conformance with the maximum permissible openings shown in **Table 1** above.

6.4.2.3 It shall not create pinch points.

6.4.2.4 It shall not be readily removable.

6.4.2.5 It shall offer maximum visibility of the equipment operation consistent with the other requirements.

6.4.2.6 It shall be inspected at intervals as outlined in ANSI B11.6 and ANSI B11.9 standards.

6.4.3 *Barrier Guard(s)*—Barrier guards shall meet the following criteria:

6.4.3.1 Prevent bodily entry into the process pinch or shear point by reaching through, over, under, or around the guard during the production cycle;

6.4.3.2 Conformance with the maximum permissible openings shown in **Table 1** above;

6.4.3.3 In itself create no pinch point between the guard and moving machine parts;

6.4.3.4 Use fasteners not readily removable by the operator so as to minimize the possibility of misuse or removal of essential parts;

6.4.3.5 Be readily inspected for its effectiveness; and

6.4.3.6 Offer maximum visibility of the hazard zone consistent with the other requirements.

6.4.3.7 *Discussion*—Take care to ensure that the guard itself has no sharp edges, burrs, and so forth, which could be a hazard.

6.4.4 *Fixed Barrier Guards*—A fixed barrier guard, when used, shall meet the criteria of **6.4.2.1 – 6.4.2.6** and shall be attached securely.

6.4.4.1 *Discussion*—Addition of an interlock to a fixed barrier guard does not necessarily make this an interlocked barrier guard.

6.4.5 *Interlocked Barrier Guards*—An interlocked barrier guard, when used, shall meet the requirements of **6.4.2.1 – 6.4.2.6** and shall be interlocked with the machine power or controls so that the machine will not operate unless the hinged or movable section of the guard is in the closed position(s).

6.4.5.1 If the interlock device is used as an alternative measure for lockout/tagout as permitted by 29 CFR 1910.147 an authorized employee shall inspect the interlock device at the beginning of each shift of operation and immediately report any damage or malfunction of the device to the supervisor. If an interlocking device is found to be defective, the machine shall not be put into operation until repaired and re-checked.

6.4.5.2 *Discussion*—The hinged or removable section(s) of this guard are intended for use when frequent access is required.

6.4.6 *Adjustable Barrier Guards*—An adjustable barrier guard shall be securely attached and shall meet the criteria of **6.4.2.1 – 6.4.2.6**.

6.5 *Hazard Zone Protective Devices*—A hazard zone device shall be provided to protect the operator and other personnel in the area by:

6.5.1 Preventing or stopping the equipment motion or condition that would create a hazard or pinch point if any portion of the body is in the hazard zone,

6.5.2 Preventing personnel from inadvertently reaching into the hazardous motion that has started or been initiated,

6.5.3 Requiring personnel to position all parts of the body away from possible hazardous conditions and position both hands on initiators during the period of time when the possibility of pinching motions or hazardous conditions is present,

6.5.4 Requiring personnel to move away from the area of possible hazardous conditions and activate an initiator at a remote location (hostage control), or

6.5.5 The employer shall be responsible for enforcing a rule that actuation of equipment controls be made only by the operator. An operator shall not be assisted by another employee operating the equipment controls.

6.5.5.1 *Discussion*—Hazard zone protective devices do not offer the degree of protection provided by a guard. These devices are secondary protection and it is permissible to use them alone or in multiples to create the greater degrees of protection. In regard to **6.5.4**, hostage controls must be located so that inadvertent entry into pinch points by parts of the body is prevented. The possibility of stumbling, slipping, or fatigue must be considered in control placement. It is acceptable to class hostage controls as a guard device if their location provides unimpeded access and visibility for the operator to the hazard zone and they are located so that possible pinch points or hazardous conditions cannot be reached.

6.5.6 *Presence-Sensing Hazard Zone Device*—A presence-sensing hazard zone device, when used, shall protect the operator by deactivating the machine or equipment motion when the presence of personnel is detected in the hazard zone.

6.5.6.1 *Discussion*—These devices are necessarily secondary protection. Their value is dependent upon their correct adjustment and maintenance.

6.5.6.2 This device shall not be installed, connected, or used in a manner that could create any hazard to the operator.

6.5.6.3 This device shall not be used as an initiator of any motion or function being protected by the device. Where or when the device is used to prevent the closing of a machine on an operator's body part, withdrawal of the operator's hands shall not automatically restart the cycle.

6.5.6.4 To the extent permitted by current recognized design techniques, this device shall be designed and applied so that any malfunction or failure of the device would prevent or stop the function or motion in the area being protected by the device.

6.5.6.5 *Discussion*—Although there is much talk about “fail-safe,” there cannot be such an absolute condition. Single failures of device components result in stopping or prevent initiation.

6.5.6.6 This device shall be installed, adjusted, and maintained only by authorized competent personnel.

6.5.6.7 *Discussion*—These devices are necessarily secondary protection. Their value is dependent upon their correct adjustment and maintenance.