

INTERNATIONAL STANDARD

NORME INTERNATIONALE



Superconductivity – **STANDARD PREVIEW**
Part 7: Electronic characteristic measurements – Surface resistance of
high-temperature superconductors at microwave frequencies

Supraconductivité –
Partie 7: Mesurages des caractéristiques électronique – Résistance de surface
des supraconducteurs haute température critique aux hyperfréquences



THIS PUBLICATION IS COPYRIGHT PROTECTED

Copyright © 2020 IEC, Geneva, Switzerland

All rights reserved. Unless otherwise specified, no part of this publication may be reproduced or utilized in any form or by any means, electronic or mechanical, including photocopying and microfilm, without permission in writing from either IEC or IEC's member National Committee in the country of the requester. If you have any questions about IEC copyright or have an enquiry about obtaining additional rights to this publication, please contact the address below or your local IEC member National Committee for further information.

Droits de reproduction réservés. Sauf indication contraire, aucune partie de cette publication ne peut être reproduite ni utilisée sous quelque forme que ce soit et par aucun procédé, électronique ou mécanique, y compris la photocopie et les microfilms, sans l'accord écrit de l'IEC ou du Comité national de l'IEC du pays du demandeur. Si vous avez des questions sur le copyright de l'IEC ou si vous désirez obtenir des droits supplémentaires sur cette publication, utilisez les coordonnées ci-après ou contactez le Comité national de l'IEC de votre pays de résidence.

IEC Central Office
3, rue de Varembe
CH-1211 Geneva 20
Switzerland

Tel.: +41 22 919 02 11
info@iec.ch
www.iec.ch

About the IEC

The International Electrotechnical Commission (IEC) is the leading global organization that prepares and publishes International Standards for all electrical, electronic and related technologies.

About IEC publications

The technical content of IEC publications is kept under constant review by the IEC. Please make sure that you have the latest edition, a corrigendum or an amendment might have been published.

IEC publications search - webstore.iec.ch/advsearchform

The advanced search enables to find IEC publications by a variety of criteria (reference number, text, technical committee,...). It also gives information on projects, replaced and withdrawn publications.

IEC Just Published - webstore.iec.ch/justpublished

Stay up to date on all new IEC publications. Just Published details all new publications released. Available online and once a month by email.

IEC Customer Service Centre - webstore.iec.ch/csc

If you wish to give us your feedback on this publication or need further assistance, please contact the Customer Service Centre: sales@iec.ch.

Electropedia - www.electropedia.org

The world's leading online dictionary on electrotechnology, containing more than 22,000 terminological entries in English and French, with equivalent terms in 16 additional languages. Also known as the International Electrotechnical Vocabulary (IEV) online.

IEC Glossary - std.iec.ch/glossary

67,000 electrotechnical terminology entries in English and French extracted from the Terms and Definitions clause of IEC publications issued since 2002. Some entries have been collected from earlier publications of IEC TC 37, 77, 86 and CISPR.

A propos de l'IEC

La Commission Electrotechnique Internationale (IEC) est la première organisation mondiale qui élabore et publie des Normes internationales pour tout ce qui a trait à l'électricité, à l'électronique et aux technologies apparentées.

A propos des publications IEC

Le contenu technique des publications IEC est constamment revu. Veuillez vous assurer que vous possédez l'édition la plus récente, un corrigendum ou amendement peut avoir été publié.

Recherche de publications IEC -

webstore.iec.ch/advsearchform

La recherche avancée permet de trouver des publications IEC en utilisant différents critères (numéro de référence, texte, comité d'études,...). Elle donne aussi des informations sur les projets et les publications remplacées ou retirées.

IEC Just Published - webstore.iec.ch/justpublished

Restez informé sur les nouvelles publications IEC. Just Published détaille les nouvelles publications parues. Disponible en ligne et une fois par mois par email.

Service Clients - webstore.iec.ch/csc

Si vous désirez nous donner des commentaires sur cette publication ou si vous avez des questions contactez-nous: sales@iec.ch.

Electropedia - www.electropedia.org

Le premier dictionnaire d'électrotechnologie en ligne au monde, avec plus de 22 000 articles terminologiques en anglais et en français, ainsi que les termes équivalents dans 16 langues additionnelles. Egalement appelé Vocabulaire Electrotechnique International (IEV) en ligne.

Glossaire IEC - std.iec.ch/glossary

67 000 entrées terminologiques électrotechniques, en anglais et en français, extraites des articles Termes et Définitions des publications IEC parues depuis 2002. Plus certaines entrées antérieures extraites des publications des CE 37, 77, 86 et CISPR de l'IEC.

INTERNATIONAL STANDARD

NORME INTERNATIONALE



Superconductivity – **STANDARD PREVIEW**
Part 7: Electronic characteristic measurements – Surface resistance of
high-temperature superconductors at microwave frequencies

<https://standards.iteh.ai/catalog/standards/sist/b249852f-88a4-4a5e-9b7d-9f6917701c65/iec-61788-7-2020>

Supraconductivité –
Partie 7: Mesurages des caractéristiques électronique – Résistance de surface
des supraconducteurs haute température critique aux hyperfréquences

INTERNATIONAL
ELECTROTECHNICAL
COMMISSION

COMMISSION
ELECTROTECHNIQUE
INTERNATIONALE

ICS 17.220.20; 29.050

ISBN 978-2-8322-7917-5

Warning! Make sure that you obtained this publication from an authorized distributor.
Attention! Veuillez vous assurer que vous avez obtenu cette publication via un distributeur agréé.

CONTENTS

FOREWORD	5
INTRODUCTION	7
1 Scope	8
2 Normative references	8
3 Terms and definitions	8
4 Requirements	8
5 Apparatus	9
5.1 Measurement system	9
5.2 Measurement apparatus for R_s	10
5.3 Dielectric rods	12
6 Measurement procedure	12
6.1 Specimen preparation	12
6.2 Set-up	13
6.3 Measurement of reference level	13
6.4 Measurement of the frequency response of resonators	14
6.5 Determination of surface resistance of the superconductor and ε' and $\tan \delta$ of the standard sapphire rods	16
7 Uncertainty of the test method	17
7.1 Surface resistance	17
7.2 Temperature	18
7.3 Specimen and holder support structure	18
7.4 Specimen protection	19
7.5 Uncertainty of surface resistance measured by standard two-resonator method	19
8 Test report	19
8.1 Identification of test specimen	19
8.2 Report of R_s values	19
8.3 Report of test conditions	19
Annex A (informative) Additional information relating to Clauses 1 to 8	20
A.1 Scope	20
A.1.1 General	20
A.1.2 Cylindrical cavity method [10] [17]	20
A.1.3 Parallel-plates resonator method [18] [19]	20
A.1.4 Microstrip-line resonance method [20] [21]	20
A.1.5 Dielectric resonator method [22] [23] [24] [25]	20
A.1.6 Image-type dielectric resonator method [26] [27]	21
A.1.7 Two-resonator method [28] [29]	22
A.2 Requirements	22
A.3 Theory and calculation equations	22
A.4 Apparatus	25
A.5 Dimensions of the standard sapphire rods	26
A.6 Dimension of the closed type resonator	28
A.7 Sapphire rod reproducibility	30
A.8 Test results	30
A.9 Reproducibility of measurement method	31

A.10	$\tan \delta$ deviation effect of sapphire rods on surface resistance	32
Annex B (informative) Evaluation of relative combined standard uncertainty for surface resistance measurement		34
B.1	Practical surface resistance measurement	34
B.2	Determination of surface resistance of the superconductor	35
B.3	Combined standard uncertainty	36
B.3.1	General	36
B.3.2	Calculation of c_2 to c_5 (12 GHz resonance at 20 K)	36
B.3.3	Determination of u_1 to u_5	37
B.3.4	Combined relative standard uncertainty	39
Bibliography		41
Figure 1 – Schematic diagram of measurement system for temperature dependence of R_s using a cryocooler		9
Figure 2 – Typical measurement apparatus for R_s		11
Figure 3 – Insertion attenuation, IA , resonant frequency, f_0 , and half power bandwidth, Δf , measured at T kelvin		14
Figure 4 – Reflection scattering parameters (S_{11} and S_{22})		16
Figure 5 – Term definitions in Table 4		18
Figure A.1 – Schematic configuration of several measurement methods for the surface resistance		21
Figure A.2 – Configuration of a cylindrical dielectric rod resonator short-circuited at both ends by two parallel superconductor films deposited on dielectric substrates		23
Figure A.3 – Computed results of the u - v and W - v relations for TE_{01p} mode		24
Figure A.4 – Configuration of standard dielectric rods for measurement of R_s and $\tan \delta$		25
Figure A.5 – Three types of dielectric resonators		26
Figure A.6 – Mode chart to design TE_{011} resonator short-circuited at both ends by parallel superconductor films [28]		27
Figure A.7 – Mode chart to design TE_{013} resonator short-circuited at both ends by parallel superconductor films [28]		28
Figure A.8 – Mode chart for TE_{011} closed-type resonator [28]		29
Figure A.9 – Mode chart for TE_{013} closed-type resonator [28]		30
Figure A.10 – Temperature-dependent R_s of YBCO film with a thickness of 500 nm and size of 25 mm square		31
Figure A.11 – Temperature dependent R_s of YBCO film when R_s was measured three times		32
Figure B.1 – Schematic diagram of TE_{011} and TE_{013} mode resonance		34
Figure B.2 – Typical frequency characteristics of TE_{011} mode resonance		35
Figure B.3 – Frequency characteristics of a resonator approximated by a Lorentz distribution		39
Table 1 – Typical dimensions of pairs of single-crystal sapphire rods for 12 GHz, 18 GHz and 22 GHz		12
Table 2 – Dimensions of superconductor film for 12 GHz, 18 GHz, and 22 GHz		13
Table 3 – Specifications for vector network analyzer		17

Table 4 – Specifications for sapphire rods 17

Table A.1 – Standard deviation of the surface resistance calculated from the results of
Figure A.11 32

Table A.2 – Relationship between x , defined by Equation (A.12), and y , defined by
Equation (A.13)..... 33

iTeh STANDARD PREVIEW
(standards.iteh.ai)

[IEC 61788-7:2020](https://standards.iteh.ai/catalog/standards/sist/b249852f-88a4-4a5e-9b7d-9f73b04a4478/iec-61788-7-2020)

<https://standards.iteh.ai/catalog/standards/sist/b249852f-88a4-4a5e-9b7d-9f73b04a4478/iec-61788-7-2020>

INTERNATIONAL ELECTROTECHNICAL COMMISSION

SUPERCONDUCTIVITY –**Part 7: Electronic characteristic measurements –
Surface resistance of high-temperature
superconductors at microwave frequencies****FOREWORD**

- 1) The International Electrotechnical Commission (IEC) is a worldwide organization for standardization comprising all national electrotechnical committees (IEC National Committees). The object of IEC is to promote international co-operation on all questions concerning standardization in the electrical and electronic fields. To this end and in addition to other activities, IEC publishes International Standards, Technical Specifications, Technical Reports, Publicly Available Specifications (PAS) and Guides (hereafter referred to as "IEC Publication(s)"). Their preparation is entrusted to technical committees; any IEC National Committee interested in the subject dealt with may participate in this preparatory work. International, governmental and non-governmental organizations liaising with the IEC also participate in this preparation. IEC collaborates closely with the International Organization for Standardization (ISO) in accordance with conditions determined by agreement between the two organizations.
- 2) The formal decisions or agreements of IEC on technical matters express, as nearly as possible, an international consensus of opinion on the relevant subjects since each technical committee has representation from all interested IEC National Committees.
- 3) IEC Publications have the form of recommendations for international use and are accepted by IEC National Committees in that sense. While all reasonable efforts are made to ensure that the technical content of IEC Publications is accurate, IEC cannot be held responsible for the way in which they are used or for any misinterpretation by any end user.
- 4) In order to promote international uniformity, IEC National Committees undertake to apply IEC Publications transparently to the maximum extent possible in their national and regional publications. Any divergence between any IEC Publication and the corresponding national or regional publication shall be clearly indicated in the latter.
- 5) IEC itself does not provide any attention of conformity. Independent certification bodies provide conformity assessment service and, in some areas access to IEC marks of conformity. IEC is not responsible for any services carried out by independent certification bodies.
- 6) All users should ensure that they have the latest edition of this publication.
- 7) No liability shall attach to IEC or its directors, employees, servants or agents including individual experts and members of its technical committees and IEC National Committees for any personal injury, property damage or other damage of any nature whatsoever, whether direct or indirect, or for costs (including legal fees) and expenses arising out of the publication, use of, or reliance upon, this IEC Publication or any other IEC Publications.
- 8) Attention is drawn to the normative references cited in this publication. Use of the referenced publications is indispensable for the correct application of this publication.
- 9) Attention is drawn to the possibility that some of the elements of this IEC Publication may be the subject of patent rights. IEC shall not be held responsible for identifying any or all such patent rights.

International Standard IEC 61788-7 has been prepared by IEC technical committee 90: Superconductivity.

This third edition cancels and replaces the second edition, published in 2006. This edition constitutes a technical revision.

This edition includes the following significant technical changes with respect to the previous edition:

- a) informative Annex B, relative combined standard uncertainty for surface resistance measurement has been added;
- b) precision and accuracy statements have been converted to uncertainty;
- c) reproducibility in surface resistant measurement has been added.

The text of this International Standard is based on the following documents:

FDIS	Report on voting
90/447/FDIS	90/452/RVD

Full information on the voting for the approval of this International Standard can be found in the report on voting indicated in the above table.

This document has been drafted in accordance with the ISO/IEC Directives, Part 2.

A list of all parts of the IEC 61788 series, published under the general title *Superconductivity*, can be found on the IEC website.

The committee has decided that the contents of this document will remain unchanged until the maintenance result date indicated on the IEC web site under "<http://webstore.iec.ch>" in the data related to the specific publication. At this date, the document will be

- reconfirmed;
- withdrawn;
- replaced by a revised edition, or
- amended.

iTeh STANDARD PREVIEW

(standards.iteh.ai)

IMPORTANT – The 'colour inside' logo on the cover page of this publication indicates that it contains colours which are considered to be useful for the correct understanding of its contents. Users should therefore print this document using a colour printer.

<https://standards.iteh.ai/catalog/standards/sist/b249852f-88a4-4a5e-9b7d-9f73b04a4478/iec-61788-7-2020>

INTRODUCTION

Since the discovery of some Perovskite-type Cu-containing oxides, extensive research and development (R & D) work on high-temperature superconductors (HTS) has been, and is being, done worldwide, and its application to high-field magnet machines, low-loss power transmission, electronics and many other technologies is in progress.

In various fields of electronics, especially in telecommunication fields, microwave passive devices such as filters using HTS are being developed and are undergoing on-site testing [1]¹ [2].

Superconductor materials for microwave resonators [3], filters [4], antennas [5] and delay lines [6] have the advantage of very low loss characteristics. The parameters of superconductor materials needed for the design of microwave low loss components are the surface resistance, (R_s) and the temperature dependence of the R_s . Knowledge of this parameter is of primary importance for the development of new materials on the supplier side and for the design of superconductor microwave components on the customer side.

R_s of high quality HTS films is generally several orders of magnitude lower than that of normal metals [7] [8] [9] [10], which has increased the need for a reliable characterization technique to measure this property. Traditionally, the R_s of niobium or any other low-temperature superconducting material was measured by first fabricating an entire three-dimensional resonant cavity and then measuring its Q -value [11]. The R_s could be calculated by solving the electro-magnetic field (EM) distribution inside the cavity. Another technique involves placing a small sample inside a larger cavity. This technique has many forms but usually involves the uncertainty introduced by extracting the loss contribution due to the HTS films from the experimentally measured total loss of the cavity.

IEC 61788-7:2020

The best HTS samples are epitaxial films grown on flat crystalline substrates and no high-quality films have been grown on any curved surface so far. What is needed is a technique that: can use these small flat samples; requires no sample preparation; does not damage or change the film; is highly repeatable; has great sensitivity (down to 1/1 000 the R_s of copper); has great dynamic range (up to the R_s of copper); can reach high internal powers with only modest input powers; and has broad temperature coverage (4,2 K to 150 K).

The dielectric resonator method is selected among several methods to determine the surface resistance at microwave frequencies because it is considered to be the most popular and practical at present. Especially, the sapphire resonator is an excellent tool for measuring the R_s of HTS materials [12] [13] [14]

The test method given in this document can also be applied to other superconductor bulk plates including low T_c materials.

This document is intended to provide an appropriate and agreeable technical base for the time being to engineers working in the fields of electronics and superconductivity technology.

The test method covered in this document is based on the VAMAS (Versailles Project on Advanced Materials and Standards) pre-standardization work on the thin film properties of superconductors.

¹ Numbers in square brackets refer to the bibliography.

SUPERCONDUCTIVITY –

Part 7: Electronic characteristic measurements – Surface resistance of high-temperature superconductors at microwave frequencies

1 Scope

This part of IEC 61788 describes measurement of the surface resistance (R_s) of superconductors at microwave frequencies by the standard two-resonator method. The object of measurement is the temperature dependence of R_s at the resonant frequency.

The applicable measurement range of R_s for this method is as follows:

- Frequency: 8 GHz < f < 30 GHz
- Measurement resolution: 0,01 m Ω at 10 GHz

The R_s data at the measured frequency, and that scaled to 10 GHz, assuming the f^2 rule for comparison, is reported.

2 Normative references (standards.iteh.ai)

The following documents are referred to in the text in such a way that some or all of their content constitutes requirements of this document. For dated references, only the edition cited applies. For undated references, the latest edition of the referenced document (including any amendments) applies.

IEC 60050-815, *International Electrotechnical Vocabulary (IEV) – Part 815: Superconductivity*

3 Terms and definitions

For the purposes of this document, the terms and definitions given in IEC 60050-815 apply.

ISO and IEC maintain terminological databases for use in standardization at the following addresses:

- IEC Electropedia: available at <http://www.electropedia.org/>
- ISO Online browsing platform: available at <http://www.iso.org/obp>

4 Requirements

The R_s of a superconductor film shall be measured by applying a microwave signal to a dielectric resonator with the superconductor film specimen and then measuring the attenuation of the resonator at each frequency. The frequency shall be swept around the resonant frequency as the centre, and the attenuation–frequency characteristics shall be recorded to obtain the Q -value, which corresponds to the loss.

The target relative combined standard uncertainty of this method is less than 20 % for the measurement temperature range from 20 K to 80 K.

It is the responsibility of the user of this document to establish appropriate safety and health practices and to determine the applicability of regulatory limitations prior to use.

Hazards exist in this type of measurement. The use of a cryogenic system is essential to cool the superconductors to allow transition into the superconducting state. Direct contact of skin with cold apparatus components can cause immediate freezing, as can direct contact with a spilled cryogen. The use of an RF generator is also essential to measure high-frequency properties of materials. If its power is too high, direct contact to human bodies can cause an immediate burn.

5 Apparatus

5.1 Measurement system

Figure 1 shows a schematic diagram of the system required for the microwave measurement. The system consists of a network analyzer system for transmission measurement, a measurement apparatus, and a thermometer for monitoring the measuring temperature.

An incident power generated from a suitable microwave source such as a synthesized sweeper is applied to the dielectric resonator fixed in the measurement apparatus. The transmission characteristics are shown on the display of the network analyzer. The measurement apparatus is fixed in a temperature-controlled cryocooler.

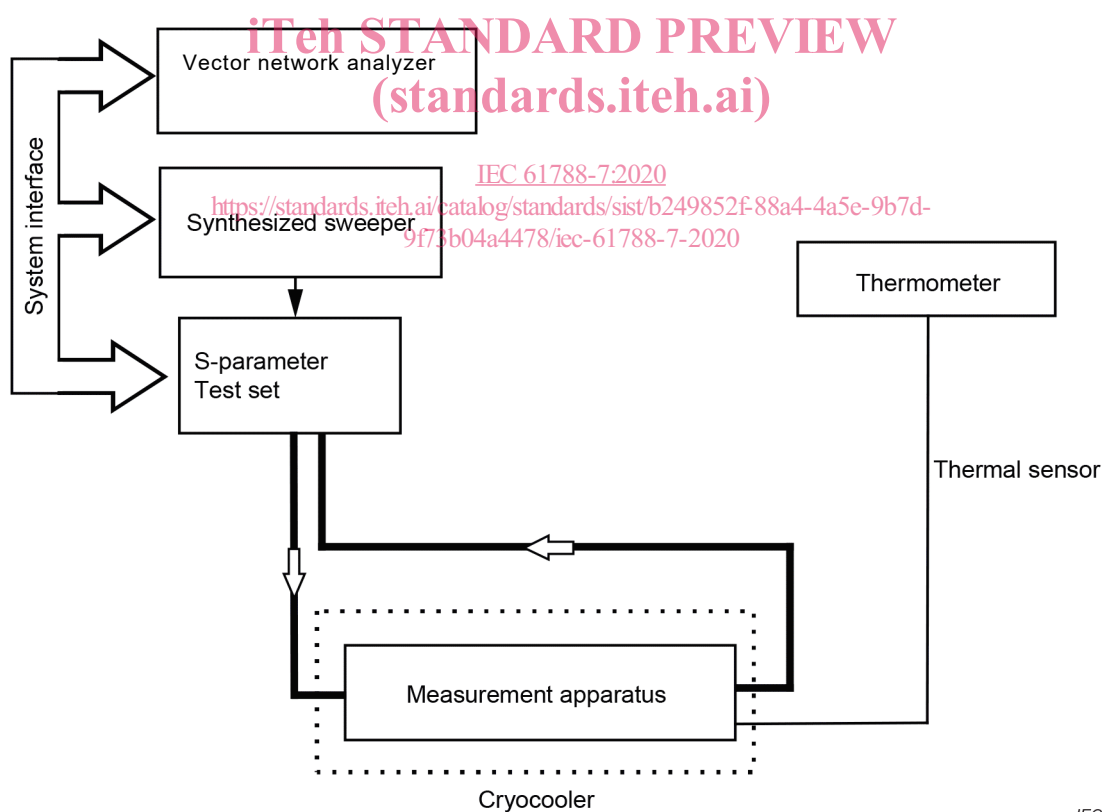

Figure 1 – Schematic diagram of measurement system for temperature dependence of R_s using a cryocooler

For the measurement of R_s for superconductor films, a vector network analyzer is recommended. A vector network analyzer has better measurement accuracy than a scalar network analyser due to its wide dynamic range. The performance requirements of the vector network analyzer are specified in 7.1.

5.2 Measurement apparatus for R_s

Figure 2 shows a schematic of a typical measurement apparatus (closed type resonator) for the R_s of HTS films deposited on a substrate with a flat surface. The upper HTS film is pressed down by a spring, which is made of phosphor bronze. The plate type spring should be used for the improvement of measurement uncertainty. This type of spring reduces the friction between the spring and the other part of the apparatus, and allows the smooth movement of superconductor films due to the thermal expansion of the dielectric rod. In order to minimize the measurement uncertainty, the sapphire rod and the copper ring shall be arranged coaxially.

Two semi-rigid cables for measuring transmission characteristics of the resonator shall be attached on both sides of the resonator in an axial symmetrical position ($\phi = 0$ and π , where ϕ is the rotational angle around the central axis of the sapphire rod). Each of the two semi-rigid cables shall have a small loop at the ends. The plane of the loop shall be set parallel to that of the superconductor films in order to suppress the unwanted Transverse Magnetic Wave Modes (TM_{mn0} modes). The coupling loops shall be carefully checked for cracks in the spot weld joint that may have developed upon repeated thermal cycling. These cables can move right and left to adjust the insertion attenuation (IA). In this adjustment, coupling of unwanted cavity modes to the interested dielectric resonance mode shall be suppressed. Unwanted, parasitic coupling to the other modes reduces the high Q -value of the Transverse Electro-Magnetic Mode (TE mode) resonator. For suppressing the parasitic coupling, special attention shall be paid to designing high- Q resonators. Two other types of resonators along with the closed type shown in Figure 2 can be used. They are explained in A.4.

iTeh STANDARD PREVIEW
(standards.iteh.ai)

[IEC 61788-7:2020](https://standards.iteh.ai/catalog/standards/sist/b249852f-88a4-4a5e-9b7d-9f73b04a4478/iec-61788-7-2020)

<https://standards.iteh.ai/catalog/standards/sist/b249852f-88a4-4a5e-9b7d-9f73b04a4478/iec-61788-7-2020>

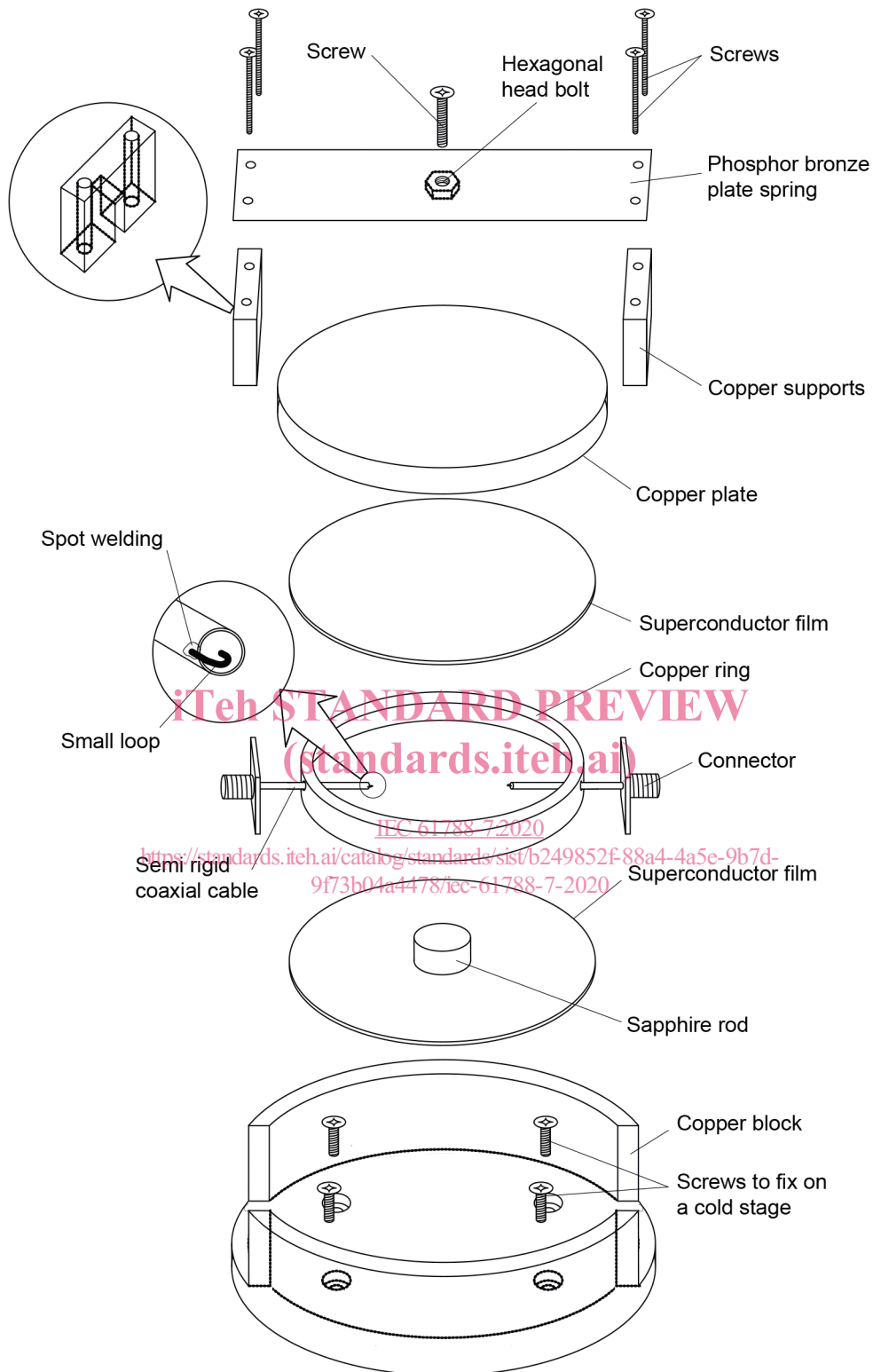

IEC

Figure 2 – Typical measurement apparatus for R_s

A reference line made of a semi-rigid cable shall be used to measure the full transmission power level, i.e. the reference level. This cable has a length equal to the sum of the two cables of the measurement apparatus. Semi-rigid cable with an outer diameter of 1,20 mm is recommended.

In order to minimize the measurement uncertainty, two superconductor films shall be set to be parallel to each other. To ensure that the two superconductor films remain in tight contact with the ends of the sapphire rod, without any air gap, both of the surfaces of the films and the ends of the rod shall be cleaned carefully.

5.3 Dielectric rods

Two dielectric rods with the same relative permittivity, ϵ' , and loss factor, $\tan \delta$, preferably cut from one cylindrical dielectric rod, are required. These two rods, standard dielectric rods, shall have the same diameter but different heights: one shall have height three times longer than the other.

It is preferable to use dielectric rods with low $\tan \delta$ to achieve the requisite measurement uncertainty on R_s . Recommended dielectric rods are single-crystal sapphire rods with $\tan \delta$ less than 2×10^{-7} at 77 K. Specifications on the sapphire rods are described in 7.1. In order to minimize the measurement error in R_s of the superconductor films, both ends of the sapphire rods shall be polished parallel to each other and perpendicular to the axis. Specifications for the sapphire rods are given in Clause 7.

The diameter and the heights of the standard sapphire rods shall be carefully designed so that the TE_{011} and TE_{013} modes do not couple to other TM, HE and EH modes, since the coupling between TE mode and other modes causes the degradation of unloaded Q . A design guideline for the standard sapphire rods is described in Clause A.5. Table 1 shows typical examples of dimensions of the standard sapphire rods for 12 GHz, 18 GHz, and 22 GHz resonance. In the R_s measurement at 22 GHz, the required film diameter can be set to 20 mm, and the measured Q_L is small, therefore the effect of the dielectric loss of sapphire rod can be reduced.

Table 1 – Typical dimensions of pairs of single-crystal sapphire rods for 12 GHz, 18 GHz and 22 GHz

Frequency GHz		Diameter, d mm	Height, h mm
12	Short rod (TE_{011} resonator)	$11,40 \pm 0,05$	$5,70 \pm 0,05$
	Long rod (TE_{013} resonator)	$11,40 \pm 0,05$	$17,10 \pm 0,05$
18	Short rod (TE_{011} resonator)	$7,60 \pm 0,05$	$3,80 \pm 0,05$
	Long rod (TE_{013} resonator)	$7,60 \pm 0,05$	$11,40 \pm 0,05$
22	Short rod (TE_{011} resonator)	$6,20 \pm 0,05$	$3,10 \pm 0,05$
	Long rod (TE_{013} resonator)	$6,20 \pm 0,05$	$9,30 \pm 0,05$

6 Measurement procedure

6.1 Specimen preparation

From uncertainty estimation, the film diameter shall be about three times larger than that of the sapphire rods. In this configuration, the increase in uncertainty of R_s due to the different radiation losses between TE_{011} and TE_{013} mode can be considered negligible, given the target relative combined standard uncertainty of 20 %. The film thickness shall be about two times larger than the magnetic-field penetration depth value at the maximum temperature in the measurement temperature range. If the film thickness is much less than two times the magnetic-field penetration depth, the measured R_s should mean the effective surface resistance.

Table 2 shows dimensions of the superconductor films recommended for the standard sapphire rods of 12 GHz, 18 GHz, and 22 GHz.

Table 2 – Dimensions of superconductor film for 12 GHz, 18 GHz, and 22 GHz

c-cut single-crystal sapphire rod		Superconductor film	
Frequency	Diameter, d	Diameter, d'	Thickness
GHz	mm	mm	μm
12	$11,40 \pm 0,05$	> 35	$\cong 0,5$
18	$7,60 \pm 0,05$	> 25	$\cong 0,5$
22	$6,20 \pm 0,05$	> 20	$\cong 0,5$

In case of using closed type resonators, the dimensions of the superconductor films shall also be designed taking into account the dimension of the copper cylinder between the superconductor films. A design guideline for the dimension of the copper cylinder of the closed type resonator is described in Clause A.6.

6.2 Set-up

Set up the measurement equipment as shown in Figure 1. All of the measurement apparatus, standard sapphire rods, and superconductor films shall be kept in a clean and dry state as high humidity may degrade the unloaded Q -value. The specimen and the measurement apparatus shall be fixed in a temperature-controlled cryocooler. The specimen chamber shall be totally evacuated. The temperatures of the superconductor films and standard sapphire rods shall be measured by a diode thermometer, or a thermocouple. The temperatures of the upper and lower superconductor films and standard sapphire rods shall not differ by more than 0,5 K. This can be achieved by covering the measurement apparatus with aluminium foil or filling the specimen chamber with helium gas.

6.3 Measurement of reference level

The level of full transmission power (reference level) shall be measured first. Fix the output power of the synthesized sweeper below 10 mW because the measurement uncertainty depends on the measuring signal level. Connect the reference line of semi-rigid cable between the input and output connectors. Then, measure the transmission power level over the entire measurement frequency and temperature range. The reference level can change several decibels when temperature of the apparatus is changed from room temperature to the lowest measurement temperature. Therefore, the temperature dependence of the reference level must be taken into account.