



Designation: **B417 – 13 B417 – 18**

Standard Test Method for Apparent Density of Non-Free-Flowing Metal Powders Using the Carney Funnel¹

This standard is issued under the fixed designation B417; the number immediately following the designation indicates the year of original adoption or, in the case of revision, the year of last revision. A number in parentheses indicates the year of last reapproval. A superscript epsilon (ϵ) indicates an editorial change since the last revision or reapproval.

1. Scope*

1.1 This test method covers a procedure for determining the apparent density of non-free-flowing metal powders. It is designed for those metal powders that do not freely flow through the Hall flowmeter funnel.

1.2 With the exception of the values for density and the mass used to determine density, for which the use of the gram per cubic centimeter (g/cm^3) and gram (g) units is the long-standing industry practice, the values in inch-pound units are to be regarded as standard. The values given in parentheses are mathematical conversions to SI units that are provided for information only, and are not considered standard.

1.3 *This standard does not purport to address all of the safety concerns, if any, associated with its use. It is the responsibility of the user of this standard to establish appropriate safety, health, and environmental practices and determine the applicability of regulatory limitations prior to use.*

1.4 *This international standard was developed in accordance with internationally recognized principles on standardization established in the Decision on Principles for the Development of International Standards, Guides and Recommendations issued by the World Trade Organization Technical Barriers to Trade (TBT) Committee.*

2. Referenced Documents

2.1 *ASTM Standards:*²

[B215 Practices for Sampling Metal Powders](#)

[B243 Terminology of Powder Metallurgy](#)

[B873 Test Method for Measuring Volume of Apparent Density Cup Used in Test Methods B212, B329, and B417](#)

3. Terminology

3.1 *Definitions*—Terms in Terminology [B243](#) are applicable to this test method.

4. Summary of Test Method

4.1 A volume of powder is permitted to flow into a container of definite volume under controlled conditions. The mass of powder per unit volume is determined and reported as apparent density, Carney (AD_C).

5. Significance and Use

5.1 This test method provides a guide for evaluation of an important physical characteristic of a powder known as the apparent density. The measured apparent density bears a relationship to the mass of powder that will fill a fixed volume die cavity. The degree of correlation between the results of this test and the performance of powders during use may vary with each particular application. Note, however, that the presence of moisture, oils, stearic acid, stearates, waxes, and the temperature of the powder mass may alter the physical characteristics of the powder.

¹ This test method is under the jurisdiction of ASTM Committee B09 on Metal Powders and Metal Powder Products and is the direct responsibility of Subcommittee B09.02 on Base Metal Powders.

Current edition approved Oct. 1, 2013; Oct. 1, 2018. Published September 2013; November 2018. Originally approved in 1964. Last previous edition approved in 2011 as B417 – 11; B417 – 13. DOI: [10.1520/B0417-13](https://doi.org/10.1520/B0417-13); [10.1520/B0417-18](https://doi.org/10.1520/B0417-18).

² For referenced ASTM standards, visit the ASTM website, www.astm.org, or contact ASTM Customer Service at service@astm.org. For *Annual Book of ASTM Standards* volume information, refer to the standard's Document Summary page on the ASTM website.

*A Summary of Changes section appears at the end of this standard

6. Apparatus

6.1 *Powder Flowmeter*³—A Carney Flowmeter (Fig. 1).

6.2 *Density Cup*³—A cylindrical brass cup (Fig. 2) having a capacity of ~~25 cm~~ 25 cm^3 . The actual cup volume shall be determined according to Test Method B873. If the measured volume of the cup is outside the tolerance in Fig. 2 ($25 \pm 0.03 \text{ cm}^3$) the cup shall not be used.

6.3 *Stand*—A stand (Fig. 1) to support the powder funnel concentric with the density cup so that the bottom of the powder funnel is approximately 25 mm (1 in.) above the top of the density cup when the apparatus is assembled as shown in Fig. 1.

6.4 *Workbench*—A level, vibration-free table or workbench to support the powder flowmeter stand.

6.5 *Balance*, readable to 0.001 g, with a minimum capacity of 200 g ~~capable of determining the mass to the nearest 0.01 g.~~

6.6 *Wire*, approximately 2.5 mm (0.10 in.) in diameter by 150 mm (6 in.) in length.

6.7 *Spatula or straight edge*—A non-magnetic spatula or straight edge of suitable dimensions for leveling off the excess powder on top of the density cup.

7. Test Specimen

7.1 The test portion shall consist of a volume of approximately 30 to 40 cm³ of metal powder obtained in accordance with Practices B215.

7.2 The test portion shall be tested as sampled. Note, however, that temperature, moisture, oils, stearic acid, stearates, waxes, and so forth may alter the characteristics of the powder.

8. Procedure

8.1 Weigh the empty density cup and record the mass to the nearest ~~0.01 g or, alternatively, 0.001 g.~~ Alternatively, place the empty density cup on the balance and tare the balance to zero.

8.2 Load the test specimen carefully into the flowmeter funnel and permit it to run into the density cup through the discharge orifice. If necessary, it may be agitated or pushed by use of the length of wire but take care to prevent the wire from entering the density cup. The density cup should not be moved during the filling operation.

8.3 When the powder completely fills and overflows the periphery of the density cup, rotate the funnel approximately 90° in a horizontal plane so that the remaining powder falls away from the cup.

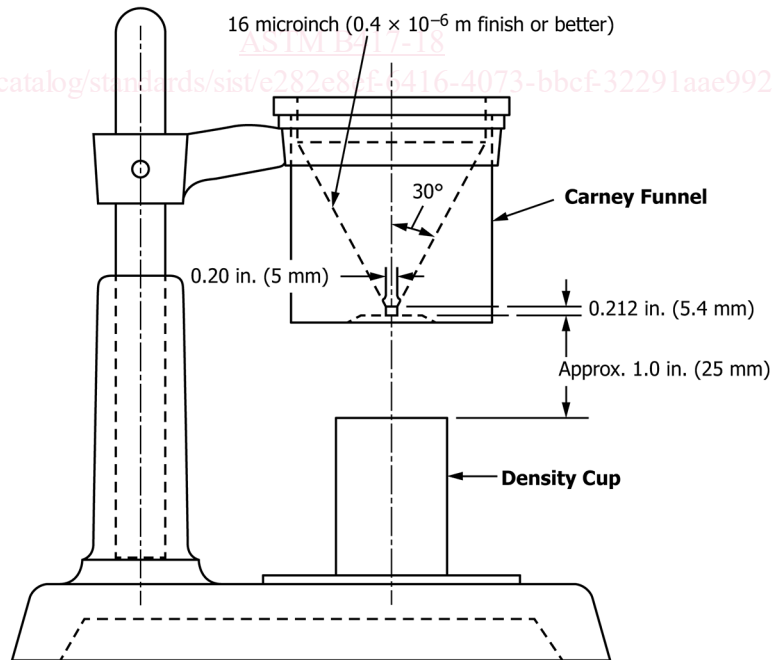

FIG. 1 Carney Flowmeter Funnel and Stand

³ The sole source of supply of the flowmeter funnel, density cup, and stand known to the committee at this time is ACu Powder International, LLC. If you are aware of alternative suppliers, please provide this information to ASTM International Headquarters. Your comments will receive careful consideration at a meeting of the responsible technical committee,¹ which you may attend.