



Designation: B223 – 08 (Reapproved 2018)

Standard Test Method for Modulus of Elasticity of Thermostat Metals (Cantilever Beam Method)¹

This standard is issued under the fixed designation B223; the number immediately following the designation indicates the year of original adoption or, in the case of revision, the year of last revision. A number in parentheses indicates the year of last reapproval. A superscript epsilon (ϵ) indicates an editorial change since the last revision or reapproval.

1. Scope

1.1 This test method covers the determination of the modulus of elasticity of thermostat metals at any temperature between -300 and $+1000^{\circ}\text{F}$ (-185 and 540°C) by mounting the specimen as a cantilever beam and measuring the deflection when subjected to a mechanical load.

1.2 The values stated in inch-pound units are to be regarded as standard. The values given in parentheses are mathematical conversions to SI units that are provided for information only and are not considered standard.

1.3 *This standard does not purport to address all of the safety concerns, if any, associated with its use. It is the responsibility of the user of this standard to become familiar with all hazards including those identified in the appropriate Safety Data Sheet (SDS) for this product/material as provided by the manufacturer, to establish appropriate safety, health, and environmental practices, and determine the applicability of regulatory limitations prior to use.*

1.4 *This international standard was developed in accordance with internationally recognized principles on standardization established in the Decision on Principles for the Development of International Standards, Guides and Recommendations issued by the World Trade Organization Technical Barriers to Trade (TBT) Committee.*

2. Referenced Documents

2.1 *ASTM Standards:*²

B388 Specification for Thermostat Metal Sheet and Strip

3. Terminology

3.1 *Definitions:*

¹ This test method is under the jurisdiction of ASTM Committee B02 on Nonferrous Metals and Alloys and is the direct responsibility of Subcommittee B02.10 on Thermostat Metals and Electrical Resistance Heating Materials.

Current edition approved Nov. 1, 2018. Published November 2018. Originally approved in 1948. Last previous edition approved in 2013 as B223 – 08 (2013). DOI: 10.1520/B0223-08R18.

² For referenced ASTM standards, visit the ASTM website, www.astm.org, or contact ASTM Customer Service at service@astm.org. For *Annual Book of ASTM Standards* volume information, refer to the standard's Document Summary page on the ASTM website.

3.1.1 *thermostat metal, n*—a composite material, usually in the form of sheet or strip, comprising two or more materials of any appropriate nature, metallic or otherwise, which, by virtue of the differing expansivities of the components, tends to alter its curvature when its temperature is changed.

3.1.2 *modulus of elasticity, n*—the ratio, within the elastic limit of a material, of stress to corresponding strain. In this test method the modulus of elasticity is calculated from the expression for the deflection of a cantilever beam under mechanical load which is transposed to read as follows:

$$E = 4P^2/dbt^3$$

where:

E = modulus of elasticity, psi or MPa,

P = load, lbf or N,

l = gage length, in. or mm,

d = specimen deflection, in. or mm,

b = specimen width, in. or mm, and

t = specimen thickness, in. or mm.

4. Apparatus (Figs. 1-3)

4.1 *Specimen Holder* for securely clamping the test specimen in a horizontal position as a cantilever beam when immersed in a bath at the desired temperature. It shall carry a micrometer depth gage for reading the deflection of the specimen and a loading rod for loading the specimen. Both of these shall extend sufficiently above the liquid level of the bath to permit the operator to perform the test at the higher test temperatures.

4.1.1 Specimen holder to be made sufficiently rigid to allow normal handling without distortion.

4.2 *Loading Rod*, $\frac{1}{8}$ in. (3.2 mm) or less in diameter, for carrying the load and transmitting its weight vertically to the free end of the cantilever specimen. It shall be made of a low expansion material; the mounting clamp and tube shall be made of the same material as the specimen mounting clamps in order to prevent a difference in expansion rates from affecting the deflection readings. The bottom end shall be conically shaped and shall rest in the conical punch mark at the free end of the specimen. Any supports shall permit free movement with specimen deflection and shall provide electrical insulation from the micrometer depth gage. Near the top shall be a holder for

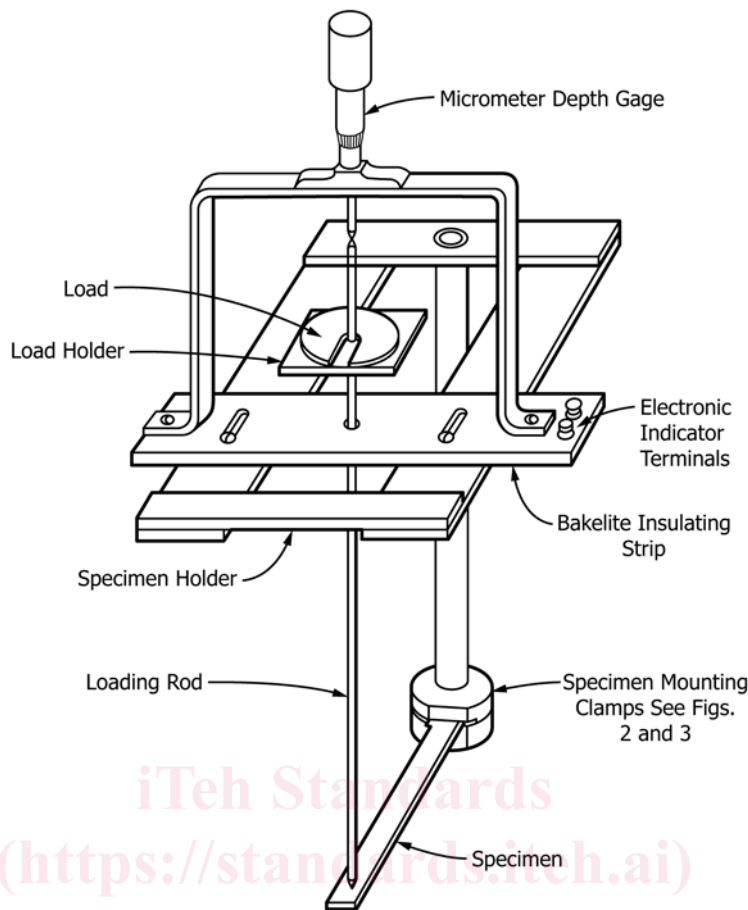

FIG. 1 Testing Machine for Determining Modulus of Elasticity of Thermostat Metal

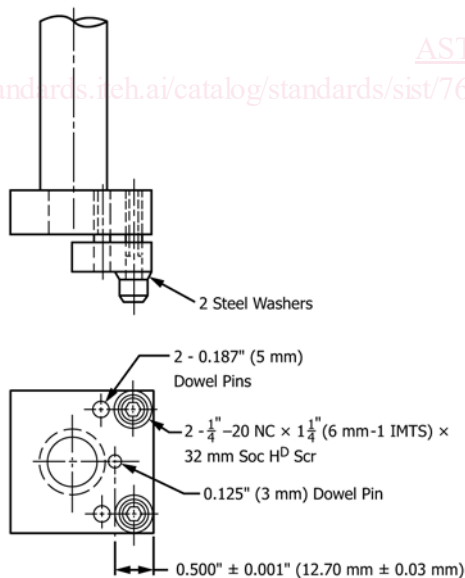

FIG. 2 Specimen Mounting Clamp Assembly

supporting the load. The weight of the loading rod and holder shall be no greater than 1 oz (28 g).

4.3 *Micrometer Depth Gage*, for measuring the deflection of the specimen to the nearest 0.0001 in. (0.002 mm). It shall be mounted directly over the loading rod. The micrometer shaft shall be in the same vertical line as the loading rod, so that readings can be taken of the top of the loading rod for no-load and full-load positions. The gage shall be insulated electrically from the specimen holder and the loading rod.

4.4 *Load*, constructed so that when placed in the holder, its center of gravity will coincide with the center of the loading rod. It shall be readily detachable for the operator's convenience in taking no-load and full-load readings and shall not be of sufficient weight to deflect the specimen more than 0.30 in. (7.6 mm).

4.5 *Bath*—A stirred liquid so that the temperature shall be substantially constant during the test.

4.6 *Electronic Indicator*, sensitive, low-current, to give a signal when the micrometer depth gage shaft completes the electrical circuit across the indicator terminals by touching the top of the loading rod. The indicator sensitivity shall be such that loading rod positions can be determined with a precision of ± 0.0001 in. (0.002 mm).