



Designation: D3756 – 18

# Standard Test Method for Evaluation of Resistance to Electrical Breakdown by Treeing in Solid Dielectric Materials Using Diverging Fields<sup>1</sup>

This standard is issued under the fixed designation D3756; the number immediately following the designation indicates the year of original adoption or, in the case of revision, the year of last revision. A number in parentheses indicates the year of last reapproval. A superscript epsilon ( $\epsilon$ ) indicates an editorial change since the last revision or reapproval.

## INTRODUCTION

When failure occurs in solid organic dielectrics that are subjected to very high, continuous, and nonuniform electrical gradients, it generally occurs by a mechanism called treeing. Materials of different molecular structures have different degrees of resistance to failure by treeing, and this resistance can sometimes be increased by the addition of other materials in low concentration.<sup>2</sup>

Trees that grow by a molecular degradation mechanism resulting from partial discharge (corona) are called electrical trees to distinguish them from water and electrochemical trees which are quite different.

This test method makes use of two opposing thin cylindrical electrodes, one sharpened to a point, the other with a hemispherical end. They are molded or inserted into blocks of the material to be tested. Because of the shape of the electrodes this is often called a needle test. This test provides a statistical estimate of electrical treeing initiation and propagation of solid dielectric materials in high, diverging electrical fields.

## 1. Scope

1.1 This test method covers the evaluation and comparison of the resistance of solid organic dielectric materials to the initiation or growth, or both, of tubular tree-like channels resulting from partial discharge (corona) and molecular decomposition that occur in the region of very high, diverging electric fields.<sup>3,4</sup>

1.2 This test method is primarily for use at a power frequency of 50 or 60 Hz.

1.3 The test is able to be carried out at room temperature or temperatures above or below room temperature. The temperature shall not exceed the softening or melting point of the sample material.

1.4 This test method can be used for any solid material into which needles can be cast, molded, or inserted with heat after molding. The resistance to tree initiation is measured by the double-needle characteristic voltage, which is only applicable to non-opaque materials so that tree can be observed optically. The resistance to tree initiation and growth is reported by the double-needle voltage life, which is applicable to both opaque and non-opaque materials.

1.5 The values stated in SI units are to be regarded as the standard.

1.6 *This standard does not purport to address all of the safety concerns, if any, associated with its use. It is the responsibility of the user of this standard to establish appropriate safety, health, and environmental practices and determine the applicability of regulatory limitations prior to use.*

1.7 *This international standard was developed in accordance with internationally recognized principles on standardization established in the Decision on Principles for the*

<sup>1</sup> This test method is under the jurisdiction of ASTM Committee D09 on Electrical and Electronic Insulating Materials and is the direct responsibility of Subcommittee D09.12 on Electrical Tests.

Current edition approved Nov. 1, 2018. Published November 2018. Originally approved in 1990. Last previous edition approved in 2010 as D3756 – 97 (2010). DOI: 10.1520/D3756-18.

<sup>2</sup> *Symposium on Engineering Dielectrics, ASTM STP 783*, ASTM, 1982, and *Symposium on Engineering Dielectrics, ASTM STP 926*, ASTM, 1986.

<sup>3</sup> W. D. Wilkens, Chapter 7, "Statistical Methods for the Evaluation of Electrical Insulating Systems," *Engineering Dielectrics, Vol IIB, Electrical Properties of Solid Insulating Materials, Measurement Techniques*, R. Bartnikas, Editor, *ASTM STP 926*, ASTM, Philadelphia, 1987.

<sup>4</sup> R. M. Eichorn, Chapter 4, "Treeing in Solid Organic Dielectric Materials," *Engineering Dielectrics, Vol IIA, Electrical Properties of Solid Insulating Materials: Molecular Structure and Electrical Behavior*, R. Bartnikas and R. M. Eichorn, Editors, *ASTM STP 783*, ASTM Philadelphia, 1983.

Development of International Standards, Guides and Recommendations issued by the World Trade Organization Technical Barriers to Trade (TBT) Committee.

## 2. Referenced Documents

### 2.1 ASTM Standards:<sup>5</sup>

**D149** Test Method for Dielectric Breakdown Voltage and Dielectric Strength of Solid Electrical Insulating Materials at Commercial Power Frequencies

**D1711** Terminology Relating to Electrical Insulation

**D1928** Practice for Preparation of Compression-Molded Polyethylene Test Sheets and Test Specimens (Withdrawn 2001)<sup>6</sup>

### 2.2 Other Document:

**ANSI/IEEE 930-1987** IEEE Guide for the Statistical Analysis of Electrical Insulation Voltage Endurance Data<sup>7</sup>

## 3. Terminology

### 3.1 Definitions:

3.1.1 *partial discharge, n*—refer to **D1711**.

### 3.2 Definitions of Terms Specific to This Standard:

3.2.1 *characteristic voltage or DNCV (double-needle characteristic voltage), n*—that voltage which, when applied for 1 h between the ends of two thin cylindrical electrodes (one sharpened to a point, the other with a hemispherical end) in a group of replicate specimens, produces observable dielectric damage at the point of the sharp electrode in half of the specimens.

3.2.2 *median voltage life ( $t_{50}$ ), n*—the time, determined from a Weibull plot, when 50 % failure occurs from a group of ten identical specimens subjected to the same voltage stress.

## 4. Summary of Method

4.1 In this test method, specimens are prepared and needles inserted to serve as electrodes. Voltage is applied to the needles and continued for 1 h in the double-needle characteristic voltage test or until electrical breakdown occurs in the double-needle voltage life test. Results are expressed as the voltage at which half of the specimens show dielectric damage in 1 h, or the median time to failure of a group of specimens subjected to a given continuous voltage, at a selected or predetermined temperature.

## 5. Significance and Use

5.1 This is a laboratory test designed to simulate the effects of (1) the presence of rough interfaces between conductor or semiconductive screen and primary insulation in an insulation system, (2) the presence of foreign particles (contaminants) in an insulation system, and (3) the presence of small voids or cavities within the insulation.

<sup>5</sup> For referenced ASTM standards, visit the ASTM website, [www.astm.org](http://www.astm.org), or contact ASTM Customer Service at [service@astm.org](mailto:service@astm.org). For *Annual Book of ASTM Standards* volume information, refer to the standard's Document Summary page on the ASTM website.

<sup>6</sup> The last approved version of this historical standard is referenced on [www.astm.org](http://www.astm.org).

<sup>7</sup> Available from American National Standards Institute (ANSI), 25 W. 43rd St., 4th Floor, New York, NY 10036.

5.2 This test method provides comparative data. The degree of correlation with actual performance in service has not been established.

## 6. Apparatus

6.1 *Power Supply*—A high voltage supply having a sinusoidal voltage output at a power frequency equipped with continuous voltage control and an adjustable protective automatic circuit-breaking device that operates at a controllable current level. See Test Method **D149**.

6.2 *Current*—Sensitive Individual Specimen Disconnect—When ten specimens are tested to failure for the voltage life test, use a disconnect circuit for each.

6.3 *Electrodes*—The critical electrode is a round steel rod, 1 mm in diameter, sharpened at one end to a controlled radius of  $3 \pm 1 \mu\text{m}$  and an included angle of  $30 \pm 1^\circ$ .

6.4 *Needle-Grinding Lathe*, for preparation of the sharpened electrodes to a controlled-point sharpness and included angle. A typical lathe and grinder combination are shown in **Fig. 1**.

6.5 *Specimen Molding Chase*, for single-step preparation of compression molded specimens containing needles. A typical chase is shown in **Fig. 2**.

6.6 *Needle-Insertion Jig*—A jig is required for slow, controlled insertion of electrodes. **Fig. 3** shows a specimen insertion jig.

6.7 *Test Chamber*—Any temperature-controlled test chamber or enclosure, which can hold at least ten specimens and maintain uniform temperature, is appropriate for this test.

## 7. Sampling

7.1 Sample so that the specimens tested will represent the entire lot.

## 8. Test Specimens

8.1 Test specimens are approximately 25-mm<sup>2</sup> blocks, 6 mm thick, containing two needle-like electrodes as shown in **Fig. 4**. Prepare by compression molding, extrusion, or cutting from

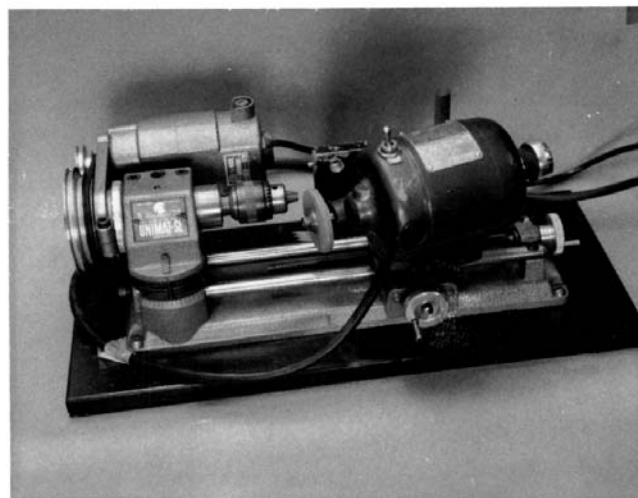

FIG. 1 Machine Setup for Needle Sharpening

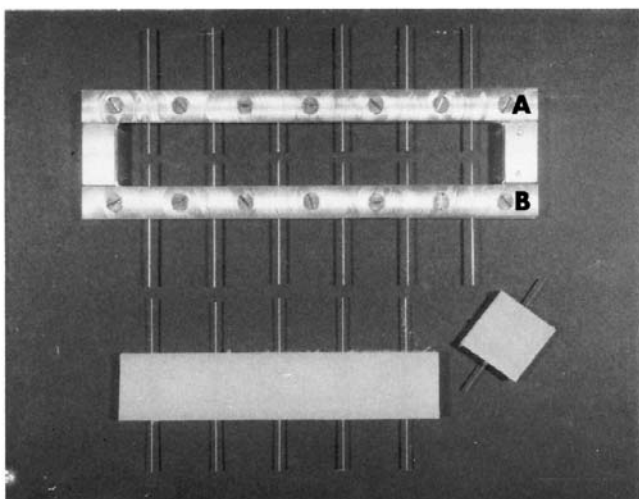

FIG. 2 Chase for Preparation of Specimens Containing Electrodes



FIG. 3 Needle Insertion Jig

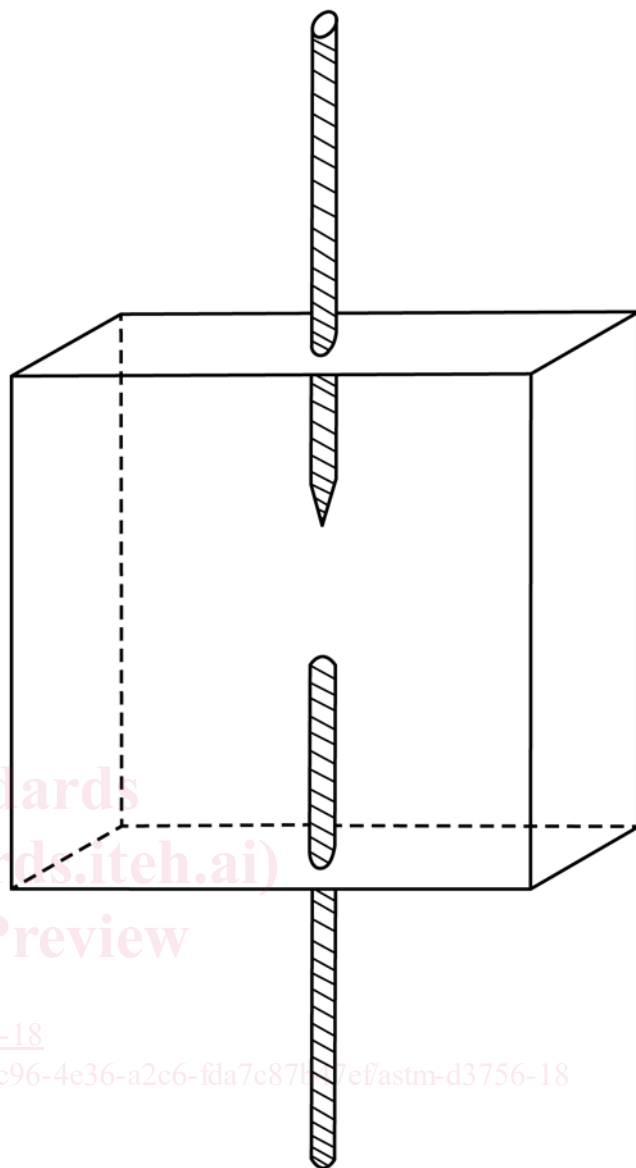

FIG. 4 Finished Specimen

finished pieces. The tips of the electrodes are separated by  $12.0 \pm 0.5$  mm for characteristic voltage determination and  $6.5 \pm 0.5$  mm for voltage life determination. The number of test specimens is at least 24 for characteristic voltage determination (that is, six specimens for each of at least four different testing voltages) and ten for voltage life determination.

**8.2 Preparation of Thermoplastic and Crosslinked Specimens**—Compression-mold plaques, 6-mm thick, of the sample material, in a steam or electrically heated hydraulic press equipped for cold-water cooling of the platens. Use a positive pressure mold, of either the picture-frame type or the milled-cavity type. Use parting sheets of cellophane, polyester film, or aluminum foil between the mold surfaces and the resin. The choice of parting sheet depends somewhat on the molding temperature, although aluminum sheets, washed with alcohol and thoroughly dried, are preferred. The size of the mold is not critical, 200 × 200 mm is recommended. For peroxide-crosslinkable materials, the typical compression-molding con-

ditions must follow the material manufacturers recommendation of temperature, time and pressure. Remove the by-products of peroxide decomposition before testing by use of a vacuum oven at elevated temperatures (80°C for seven days for XLPE using dicumyl peroxide).

8.2.1 After molding, cut the plaque into 25-mm square blocks with square and smooth edges. Store the squares under standard laboratory conditions, 23°C and 50 % relative humidity, and protect them from dirt and atmospheric contamination until used.

**8.3 Insertion of Needles**—Insert the needle electrodes into the specimen blocks slowly and carefully to avoid orientation strains, formation of cavities, and damage to the sharp points. Use a jig, such as the one shown in Fig. 3, to ensure that every needle will be inserted under identical conditions.

8.3.1 Make the insertions as follows: Place twelve specimen blocks in the slots provided for them and lightly clamp into